

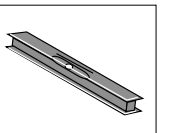

Assembly Instructions

Multi Line 6'x8'

255x193x203cm / 100 1/2"x76"x80"

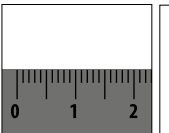
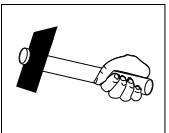
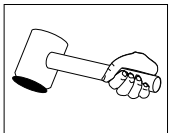
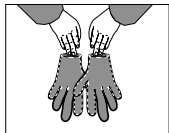
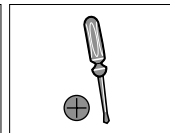
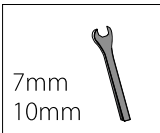
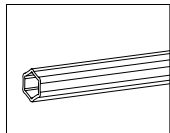
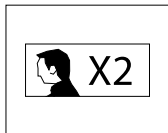
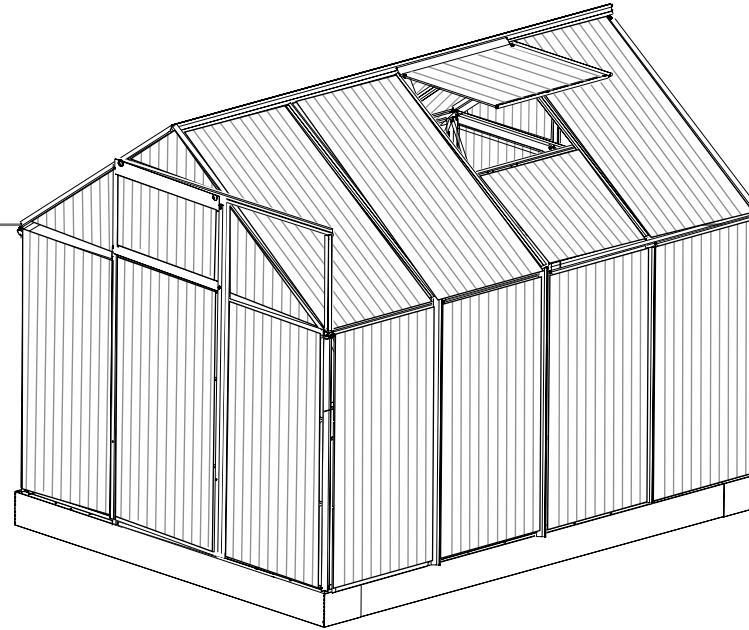

English_69717

Company information:
Palram Americas Inc.
9735 Commerce Parkway
Kutztown, PA, USA

Greenhouse Service Center:
Toll Free: (877) 627-8476

E-Mail: greenhouseUSA.support@palram.com

www.palramapplications.com



IMPORTANT

Please read these instructions carefully before you start to assemble this greenhouse. Keep these instructions in a safe place for future reference.

⇒ Customer Service

For assistance with assembly or for replacement parts – please log onto our website or call our service line (number is on the title page).
www.palamapplications.com

Additional information can be found at our website: www.palamapplications.com

⇒ Safety Advice

- It is of utmost importance to assemble all of the parts according to the directions. Do not skip any step.
- We strongly recommend using work gloves during assembly.
- Always wear shoes and safety goggles when working with extruded aluminium.
- If using a step ladder or power tools ensure that you follow the manufacturer's safety advice.
- Do not touch overhead power cables with the aluminium profiles.
- Do not attempt to assemble the greenhouse in windy or wet conditions.
- Dispose of all plastic bags safely keep them out of reach of small children.
- Keep children away from the assembly area.
- Do not lean against or push the greenhouse during construction.
- Do not position your greenhouse in an area exposed to excessive wind.
- Do not attempt to assemble this greenhouse if you are tired, have taken drugs or alcohol or if you are prone to dizzy spell.
- Hot items such as recently used grills, blowtorches etc. must not be stored in the greenhouse. Ensure there are no hidden pipes or cables in the ground before inserting the pegs.
- This product is designed to use as greenhouse only.

⇒ Care & Maintenance

When your greenhouse needs to be cleaned, use a mild detergent solution and rinse with cold clean water. DO NOT use acetone, abrasive cleaners or other special detergents to clean the clear panels.

⇒ Tools & Equipment

- Tape measure
- Work gloves
- Plastic or rubber mallet
- Lubricant
- Phillips head screwdriver
- Step ladder

- Drill bit
- Large hammer
- Scissors
- Spanner
- T001



⇒ Before Assembly

This is a multi-part assembly best achieved by two people. Allow at least half a day for assembly process.

Selecting a site - the greenhouse must be assembled, positioned and fixed on a flat level surface.

Choose a sunny position away from overhanging trees.

We are strongly recommend to fix your greenhouse directly to a solid concrete foundation. When doing that use the pre drilled holes in the metal base supplied.

Take out all components parts of the packages. Sort the parts and check against the contents parts list.

During assembly parts should be laid out close at hand. Keep all small parts (screws etc.) in a bowl so they do not get lost.

4 Prefix of the parts reference in the assembly instructions:

A- Aluminum profiles and parts

P5XX– Polycarbonate panels

P3XX– Plastic parts

M– Metal parts

4XX– Screws, nuts, disks, etc.

TXX - Tools

⇒ During Assembly

Carry out the assembly steps in the order set out in the instructions.

Step 1: Make sure the base is square by measuring the diagonals and level by using a spirit level.

Step 2: Part A162 is the front door threshold. Fixing it determines the front side of the greenhouse.

Step 3: The end of all profiles, indicated by an arrow, is always upward.

Step 5,6,7,12,15: The oval hole in the crossbars A256 should always be assembled to the base of the greenhouse.

Step 19-20: Decide on the window's location before assembly. Window can be installed in one of the indicated options.

Step 25: Panel glazing and sealing: Do not assemble the next panel before the previous one is fixed with its sealing strip.

Step 34: You may use Silicon lubricant spray in order to help you slide **R303** into profile **A173**.



Step 44: Firmly connect the greenhouse to a level final position immediately after completion of the assembly.

Screws 411 and nuts 412 are used throughout the assembly process.

- Screws 411 are to be assembled from the outside and nuts 412 from the inside of the greenhouse.
- Do not fasten screws and nuts (411 & 412) more than 2-3 turns only. Do not tighten them until completion of the panels' assembly, if not specified otherwise.

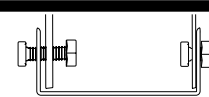

Contents

Item	Inc./cm	Qty.
M243	91 ³ / ₄ / 233	2

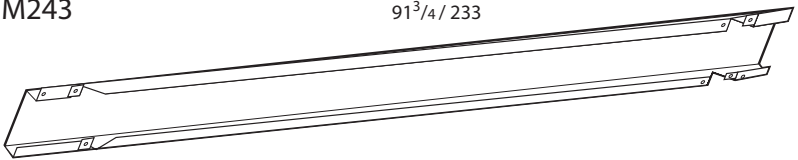

M244	91 ³ / ₄ / 233	2
------	--------------------------------------	---

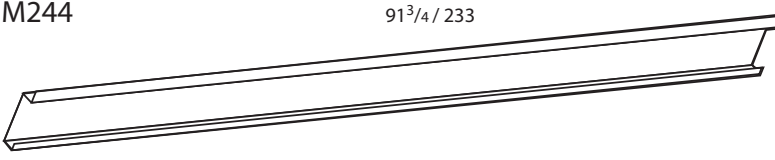

A141	97 ¹ / ₂ / 245	1
------	--------------------------------------	---

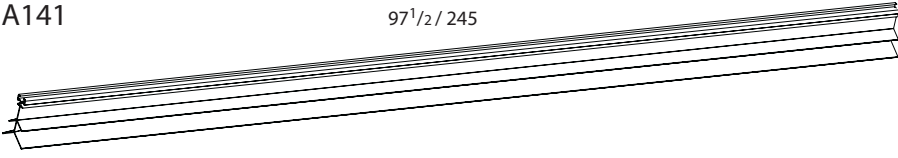

A136	96 ¹ / ₂ / 245	2
------	--------------------------------------	---

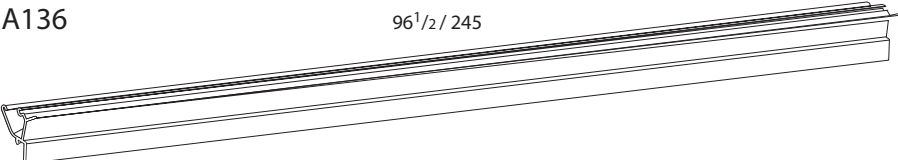

P541	1
------	---



P544	2
P545	2



P580	45" x 114.5 cm	7
------	----------------	---



P542	1
------	---

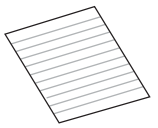

P543	1
P546	1

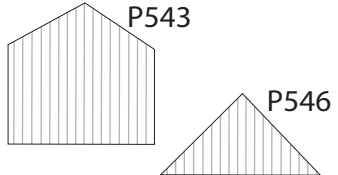

P540	44 ³ / ₄ " x 113.5 cm	14
------	---	----



Item	Inc./cm	Qty.
A283	23 ¹ / ₄ / 59	5

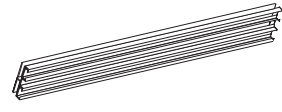

A260	24 ³ / ₄ / 63	1
------	-------------------------------------	---



A261	15 ³ / ₄ / 40	1
------	-------------------------------------	---

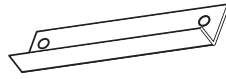

A211	24 ¹ / ₄ / 61.5	1
------	---------------------------------------	---



Item	Inc./cm	Qty.
A151	23 / 58.5	1

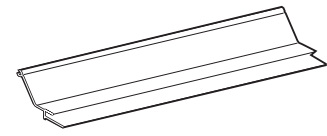

A271	23 / 58.5	1
------	-----------	---

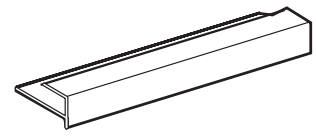

A282	21 ¹ / ₂ / 55	2
------	-------------------------------------	---



A182	24 ¹ / ₄ / 61.5	1
------	---------------------------------------	---

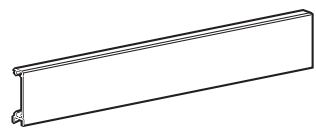

A174	24 ¹ / ₄ / 61.5	1
------	---------------------------------------	---





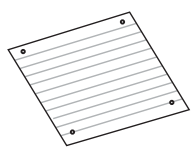

P547	1
------	---

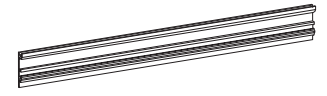



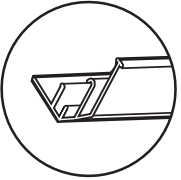
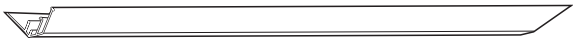
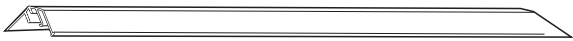

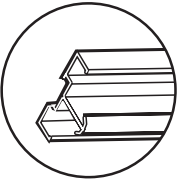
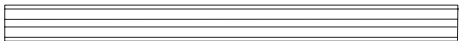

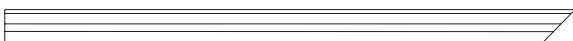
A192	24 ¹ / ₄ / 61.5	1
------	---------------------------------------	---

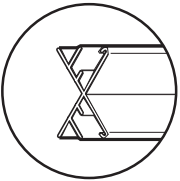
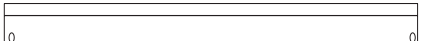

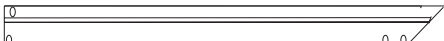
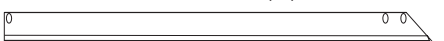
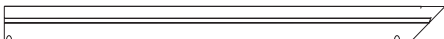
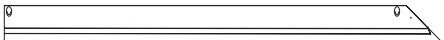



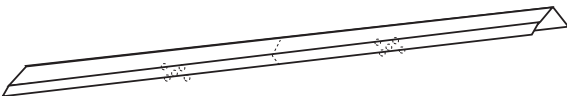

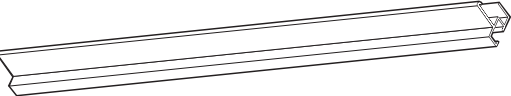









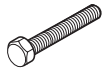

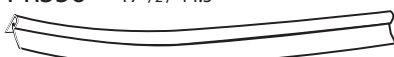
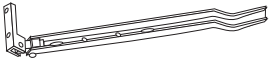



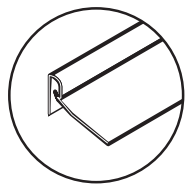

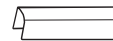

Contents

Item	Inc./cm	Qty.
		
A203	61 ¹ / ₂ / 156	1
		
A204	61 ¹ / ₂ / 156	1
		
A162	38 ¹ / ₂ / 98	1
		
		
A102	44 ¹ / ₄ / 112.5	12
		
A103	62 ¹ / ₄ / 158.5	1
		
A104	62 ¹ / ₄ / 158.5	1
		

Item	Inc./cm	Qty.
		
A111	44 ³ / ₄ / 113.5	2
		
A112	44 ³ / ₄ / 113.5	2
		
A113	44 ³ / ₄ / 114	1
		
A114	44 ³ / ₄ / 114	1
		
A115	44 ³ / ₄ / 114	1
		
A116	44 ³ / ₄ / 114	1
		
T001	7 ³ / ₄ / 20	1
		

Item	Inc./cm	Qty.
A222	48 ³ / ₄ / 124	1
		
M285	72 ³ / ₄ / 185	1
		
A256	50 ³ / ₄ / 129	8
		
A173	59 / 150	2
		

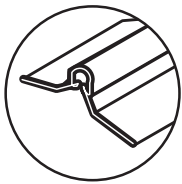
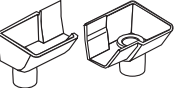
Contents

Item	Inc./mm	Qty.	Item	Inc./mm	Qty.	Item	Inc./mm	Qty.	Item	Inc./mm	Qty.			
T341		8	P333		1	422 M4		2	R360		2	R303		2
T340		7	P399		2	441 M6x1.77/M6x45		1	PR351 44 / 112 (2 spare)		22	PR356 17 ¹ / ₂ / 44.5		2
A306		1	411 M6x0.39/M6x10		100	442 0.26/6.5		1	PR353 11 ³ / ₄ / 30		2			
P328 (1 spare)		27	412 M6		100	445 8x1/5/M8x7		4	P361		113			
A323		2	421 M4x0.63/M4x16		4	447 M8x0.63/M8x16		4	PA351 44 / 112 (2 spare)		14			
M307		4	423 M4 SL		2	4008 0.6x0.16/16x4.2		6	PA352 22 / 57		2			
P324		4	P304		2				PA353 17 ¹ / ₂ / 44.5		2			

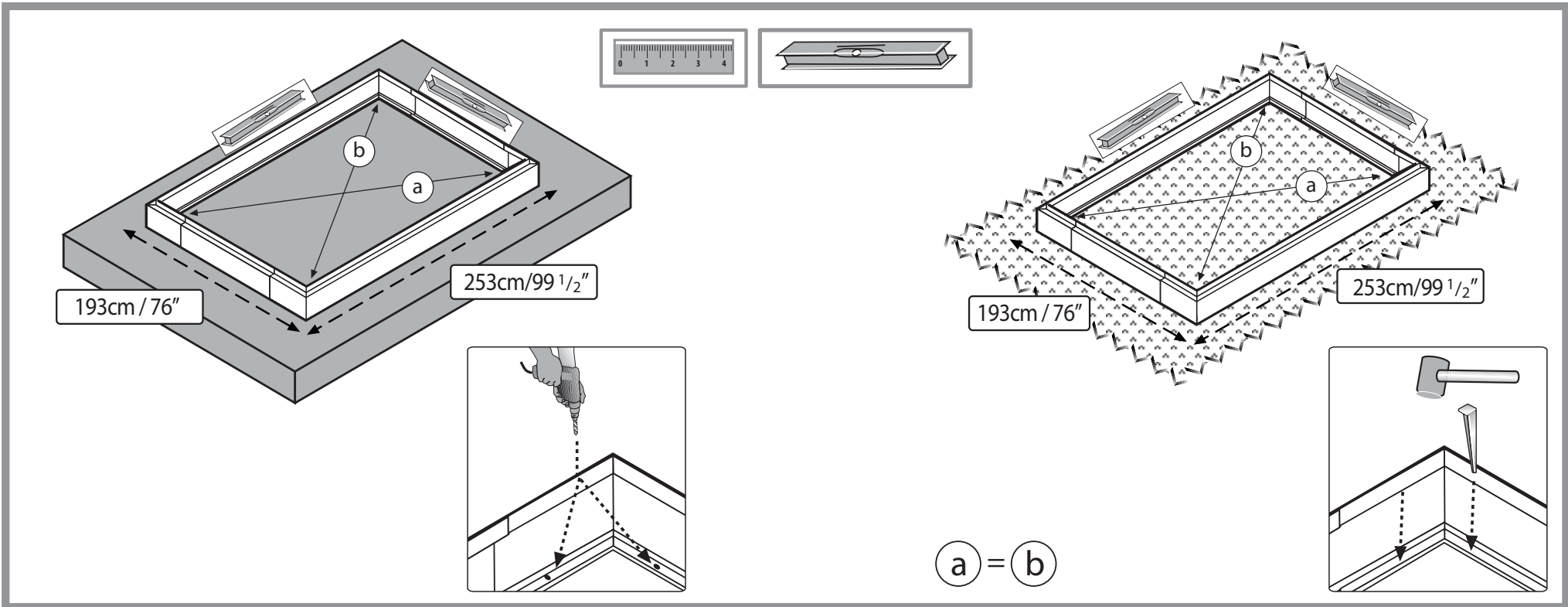
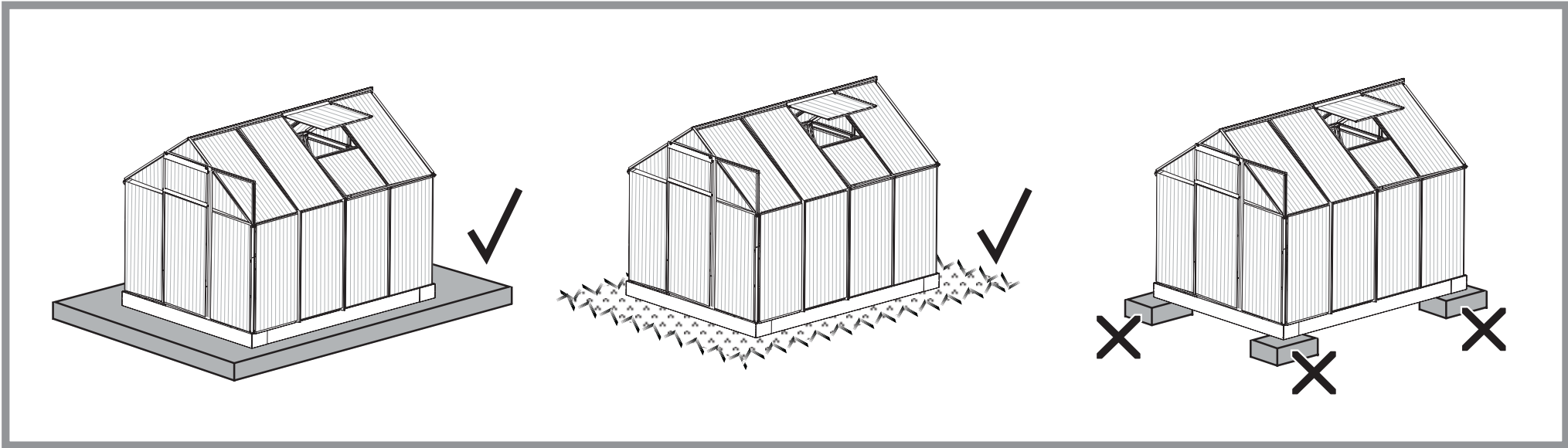

1

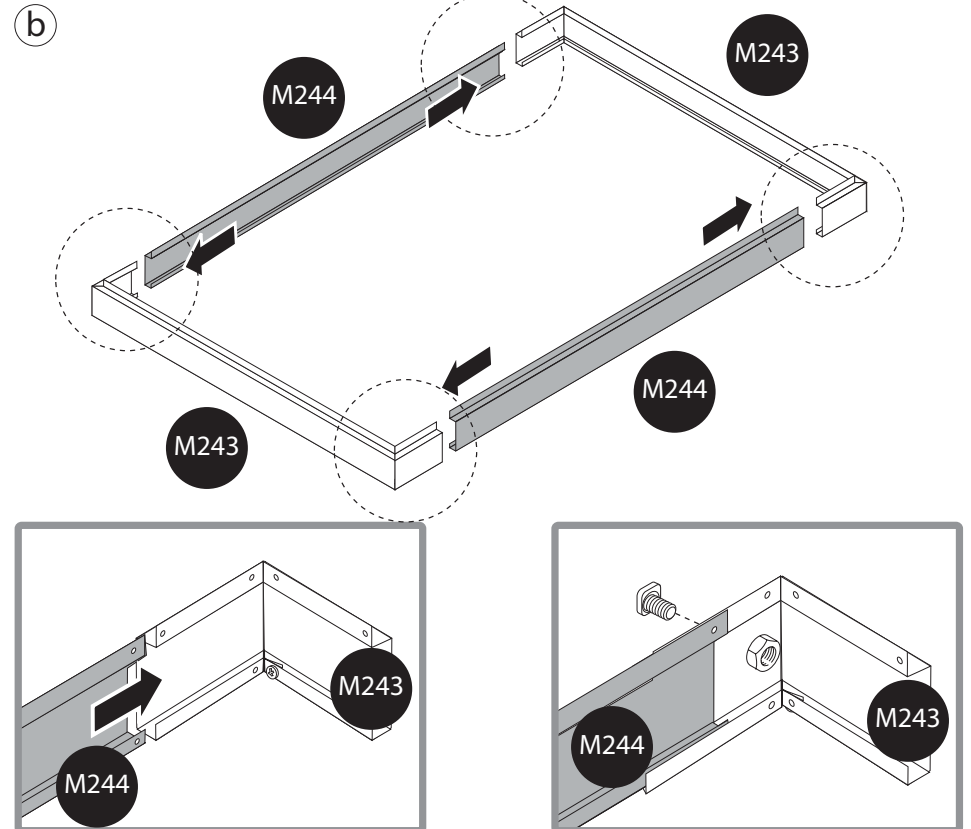
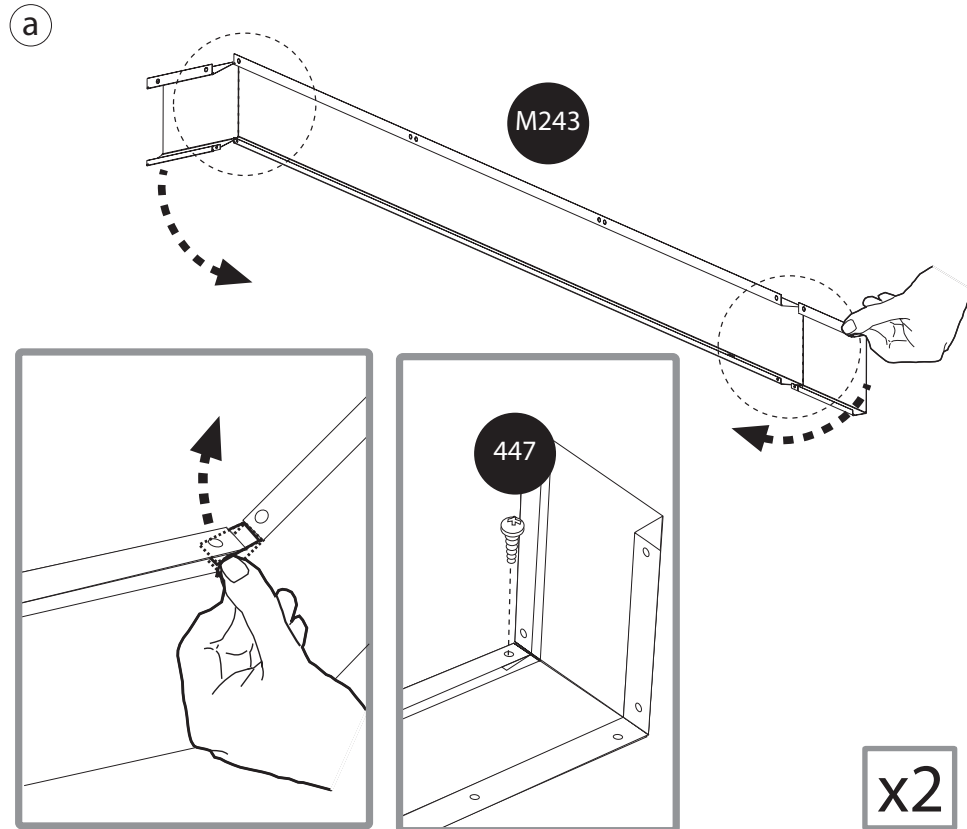
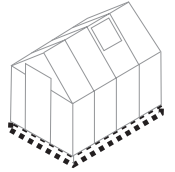

2



T001

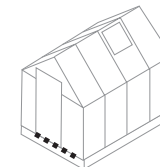

A162



412



x3

411



x3

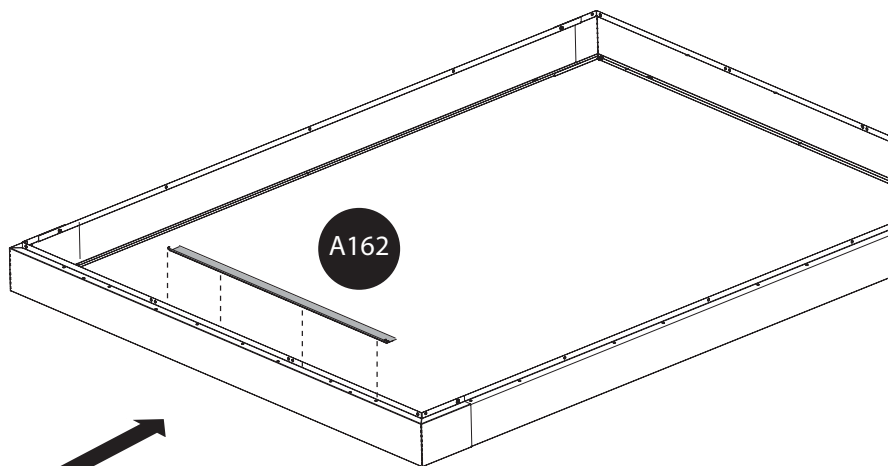

A162

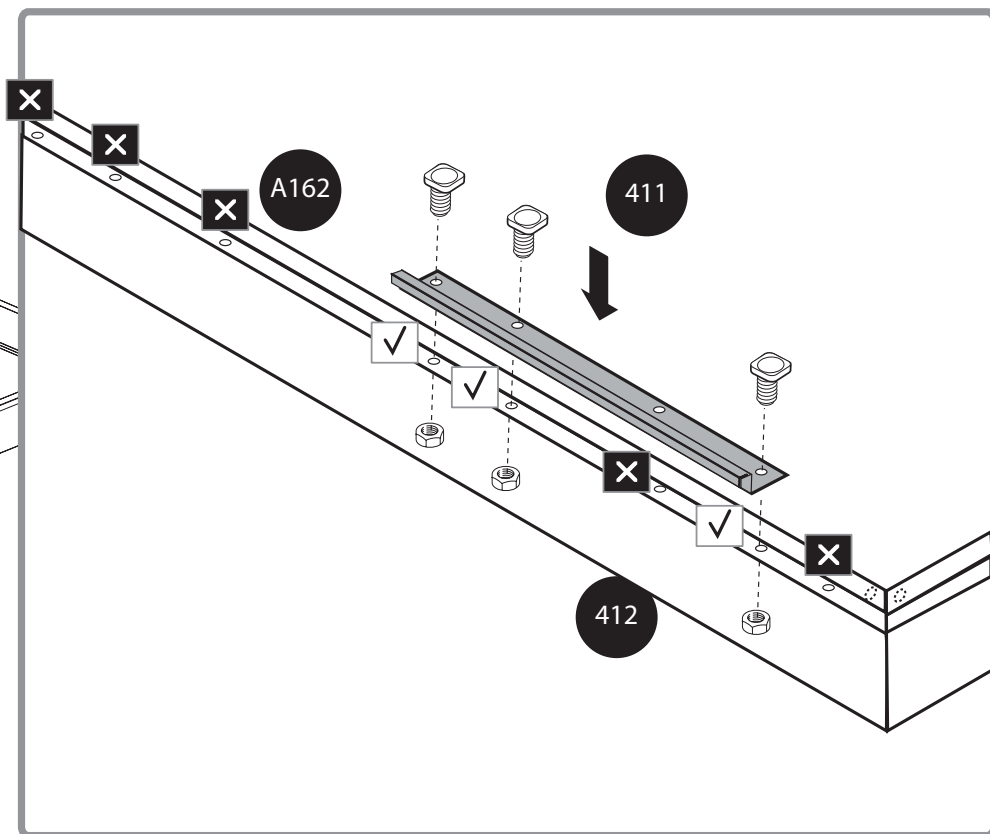

A162

411

412

- EN Door
- GR Tür
- FR Porte
- SP Puerta

3

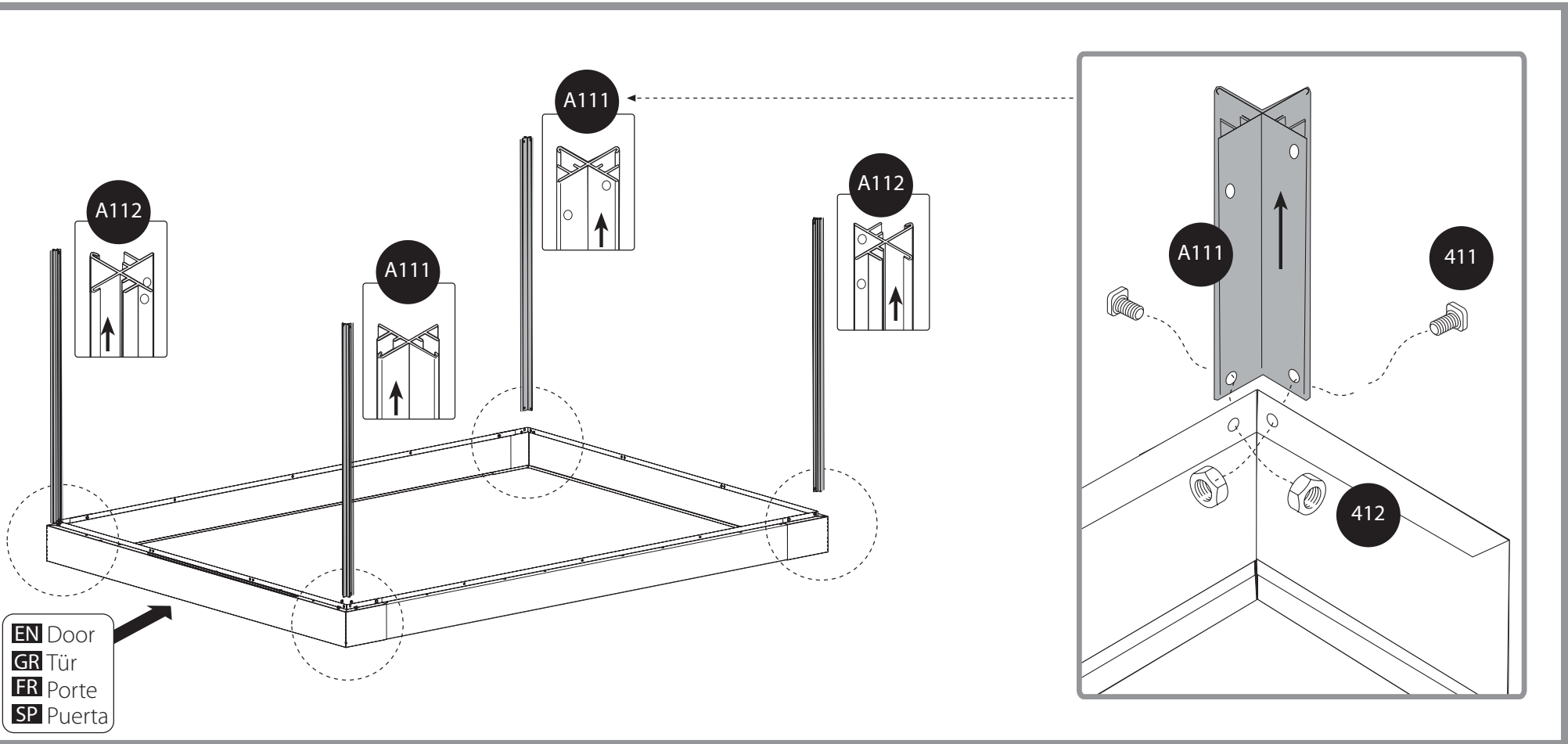
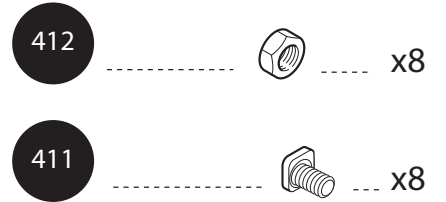
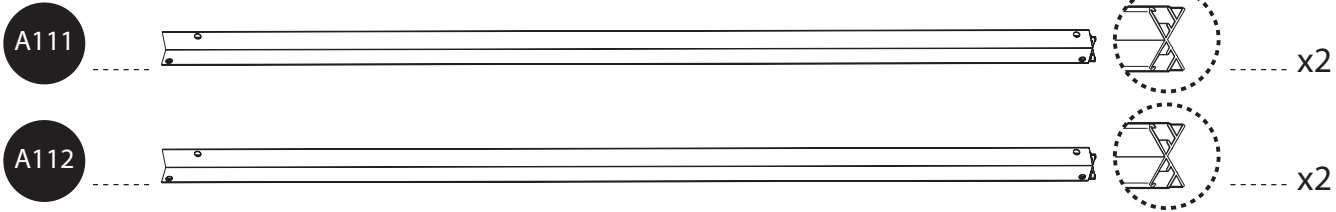
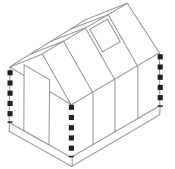

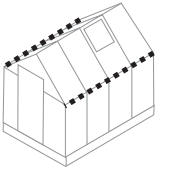

A136

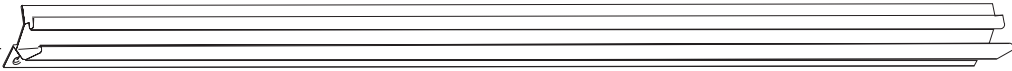

x2

P324

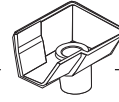

x4

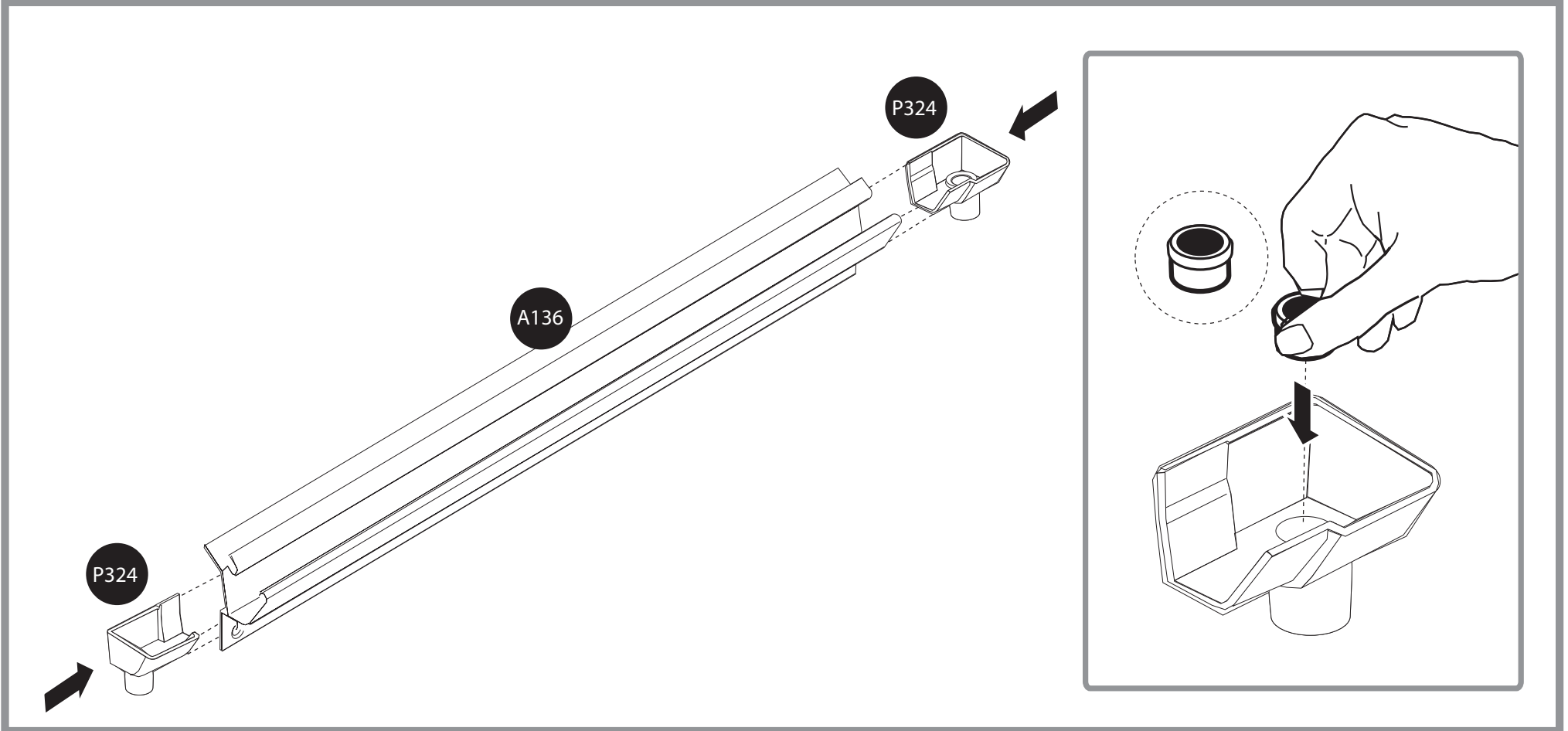

5

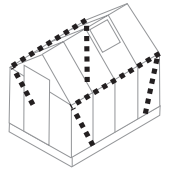

A136 x2

A256 x4

412 x8

411 x8

a + b

A136

A256

c

a

b

c

6

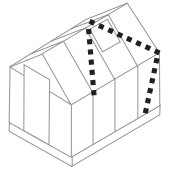

A256 x2

412 x2

M285 x1

411 x2

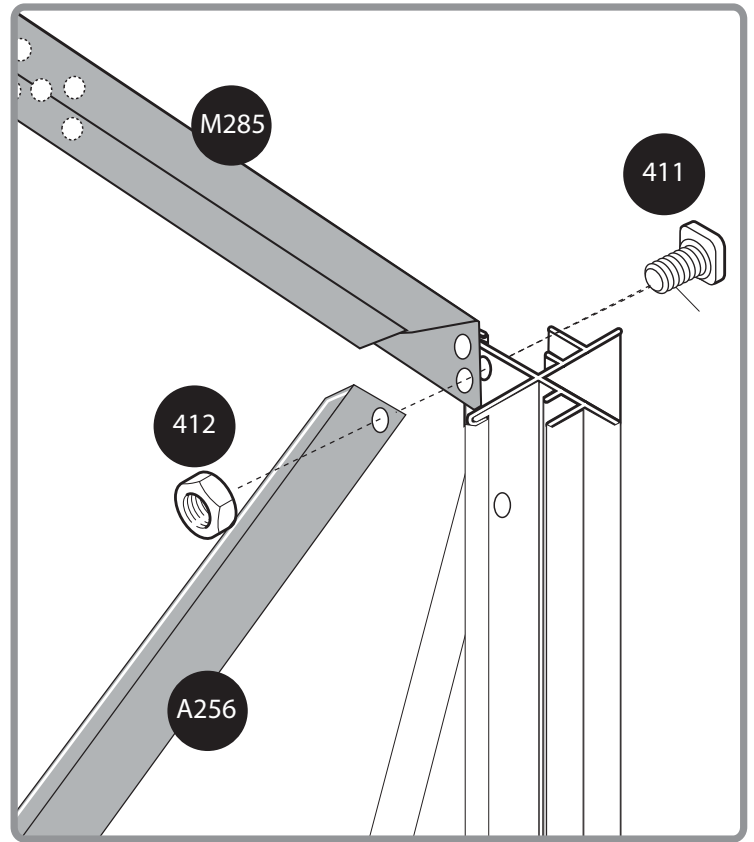
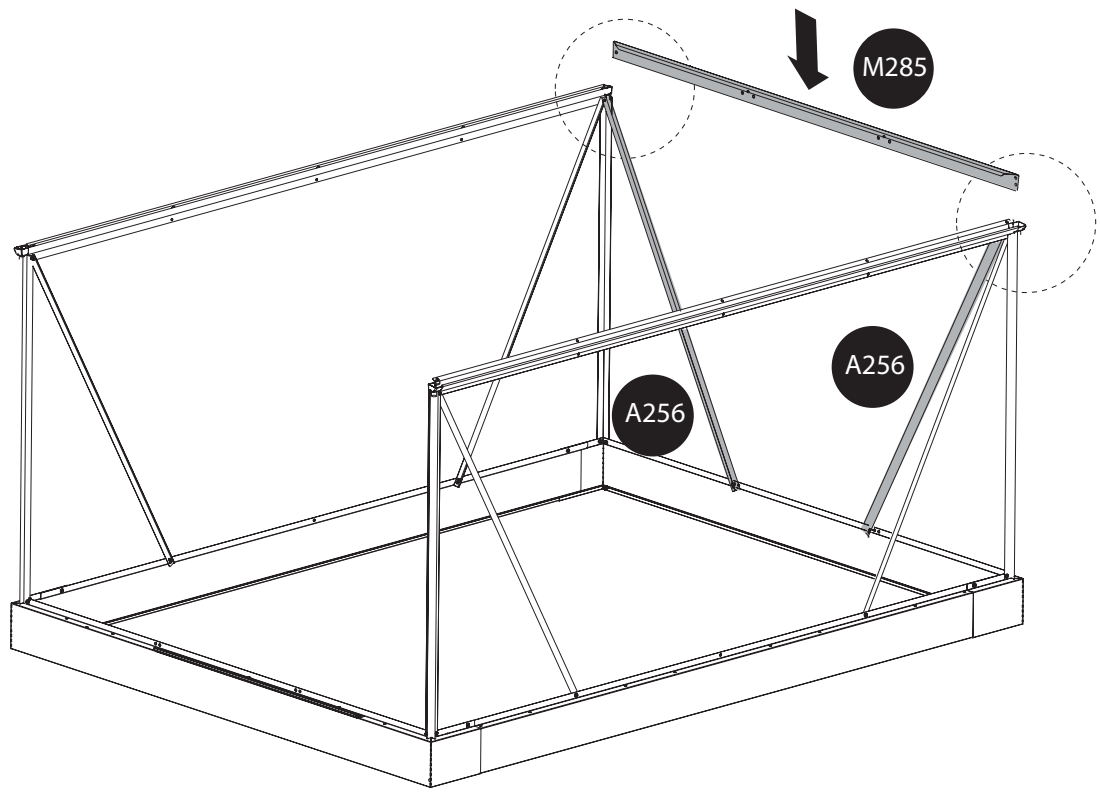

7

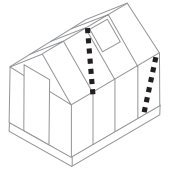

412

 x2

411

 x2

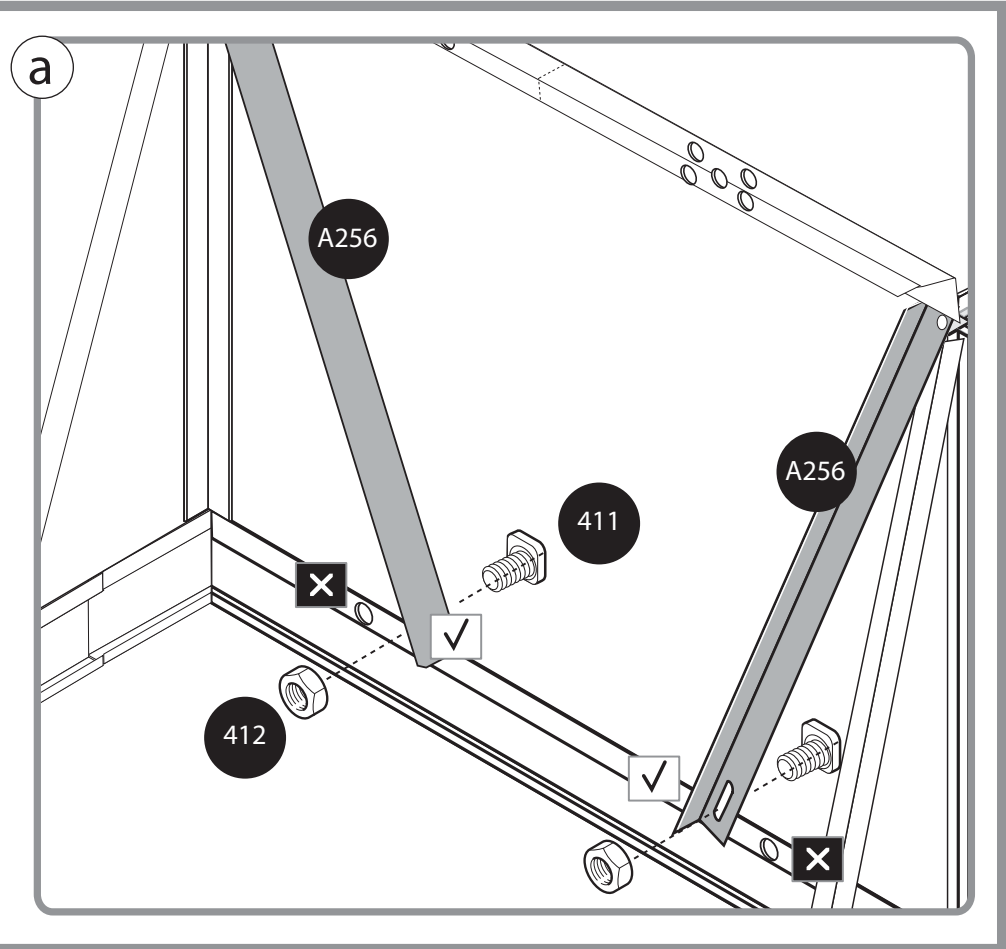
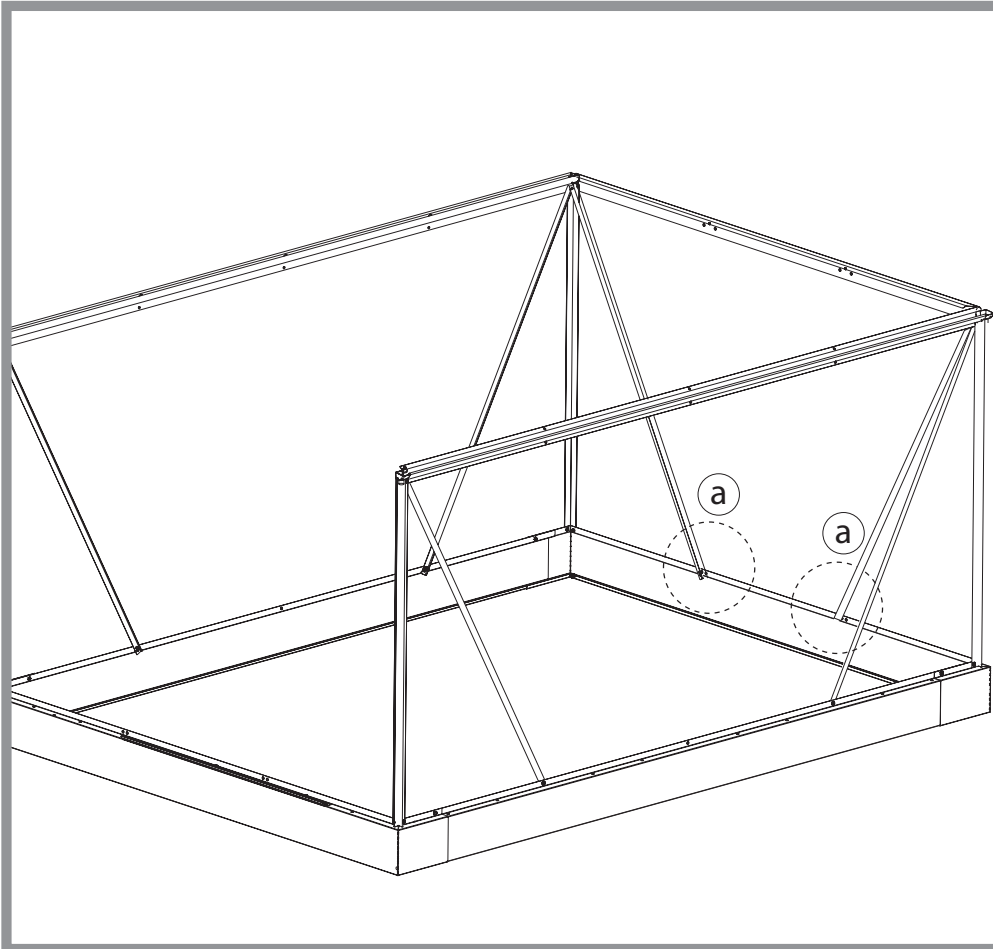

8

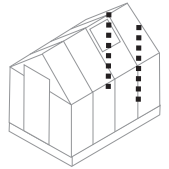

A103	 x1	412		x2
A104	 x1	411		x2

a

411

b

A104

A103





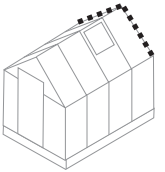

412

412

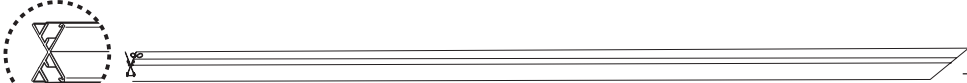
c

9

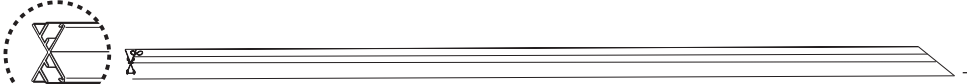

		x1			x6
		x1			x6

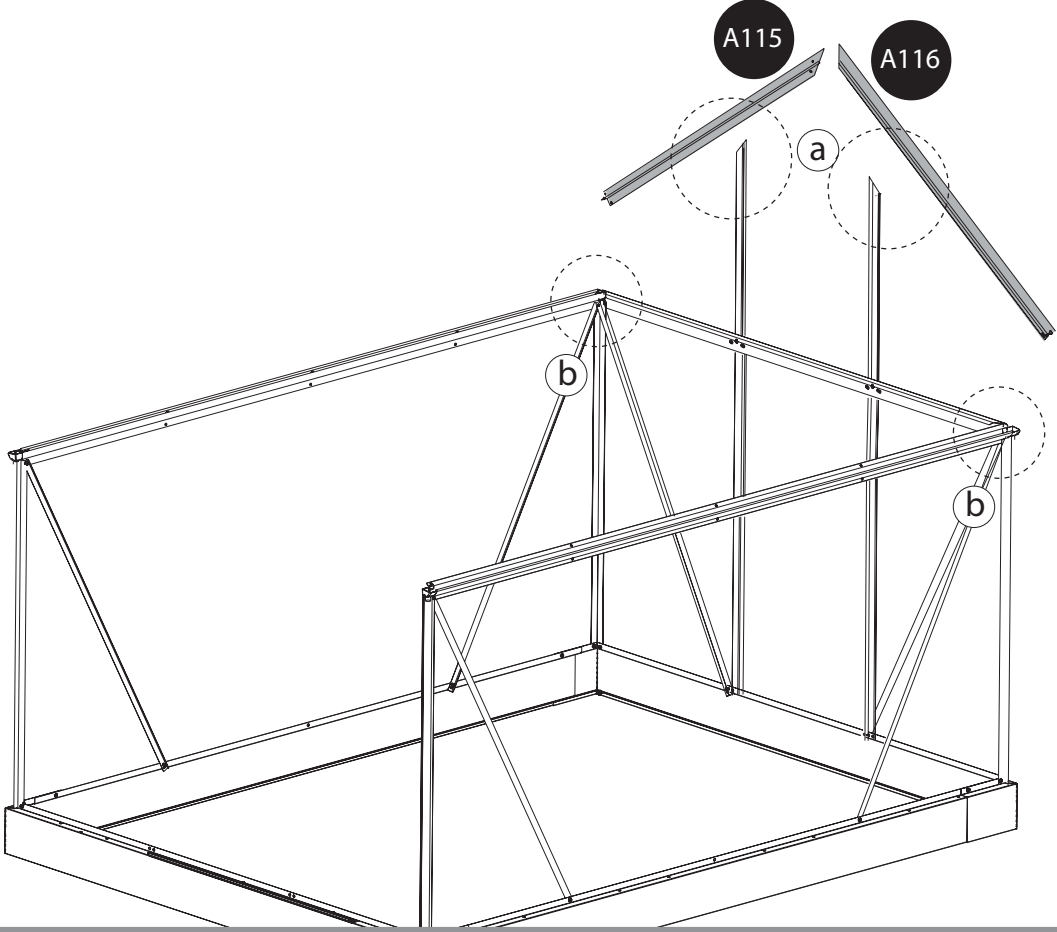

a

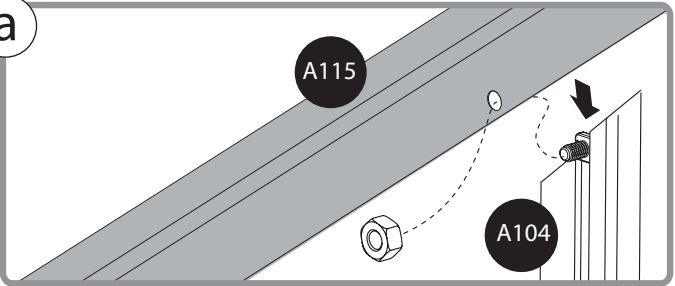

b

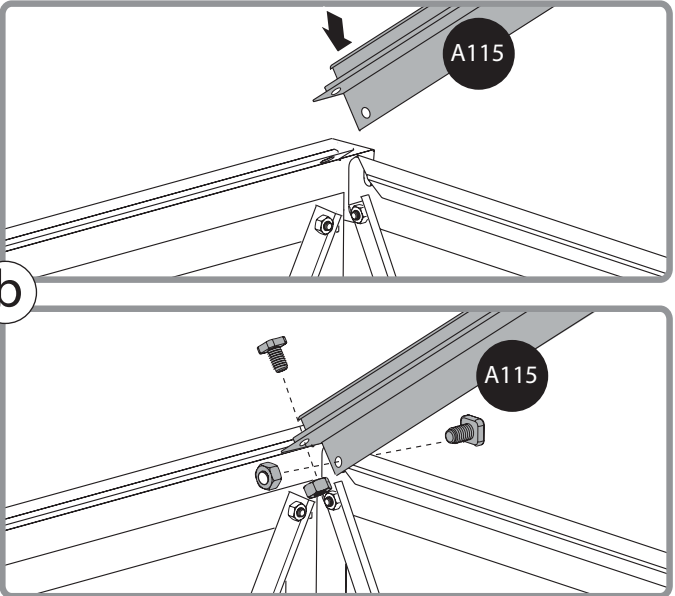

10

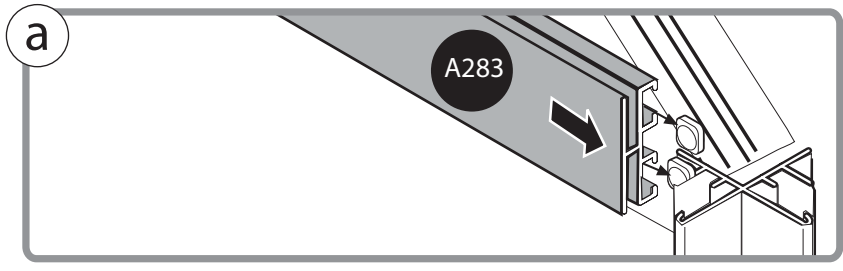
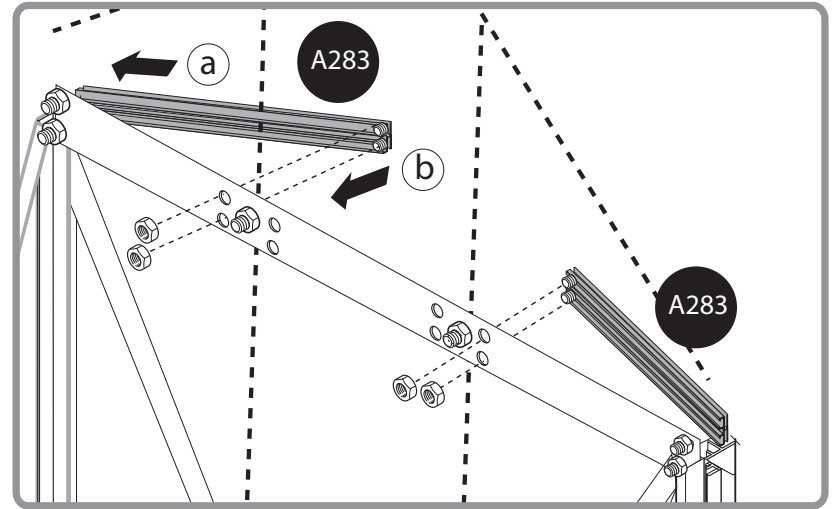
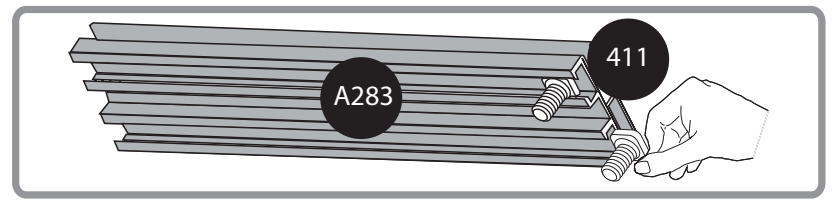
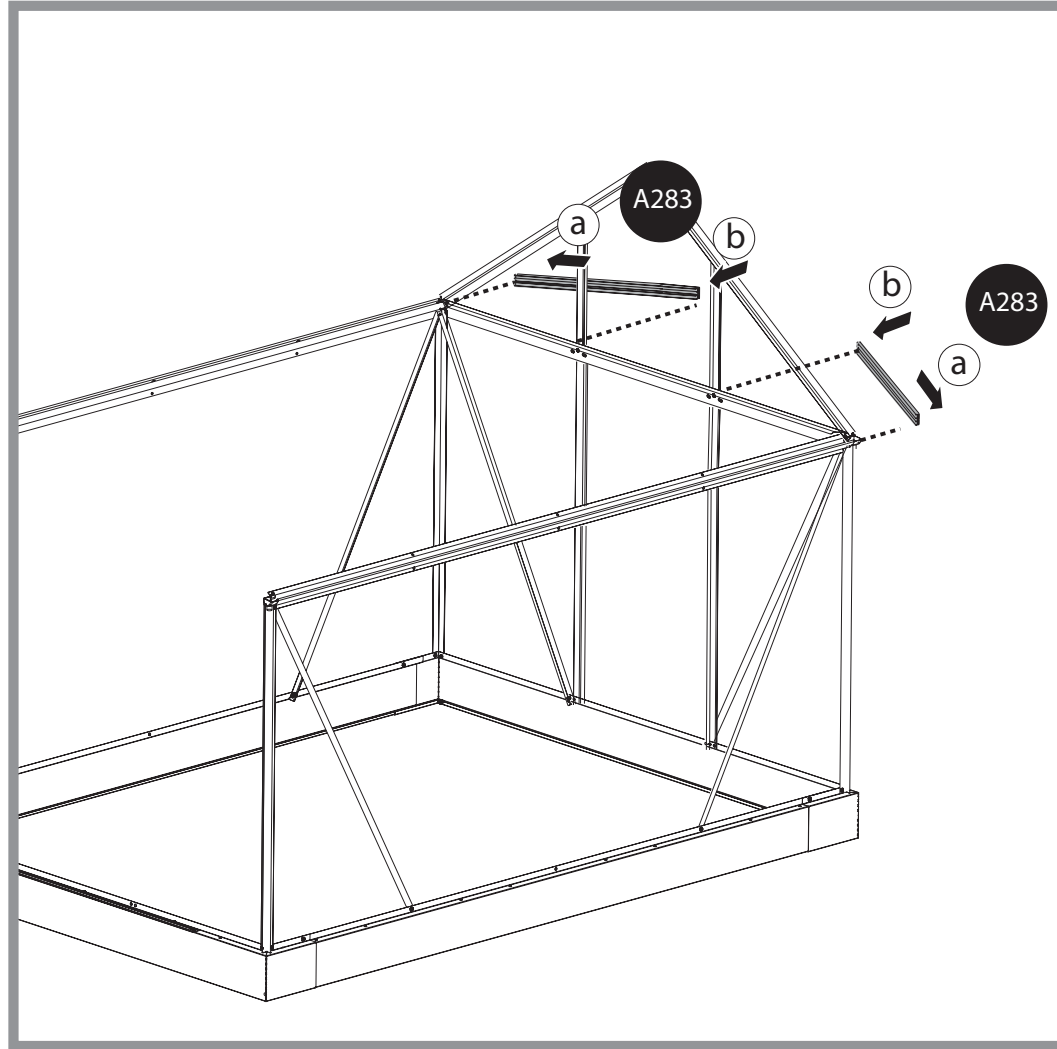
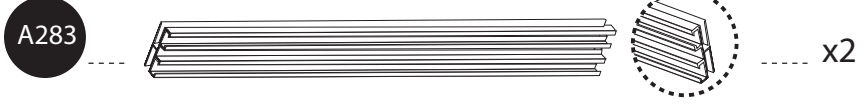
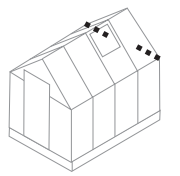

11

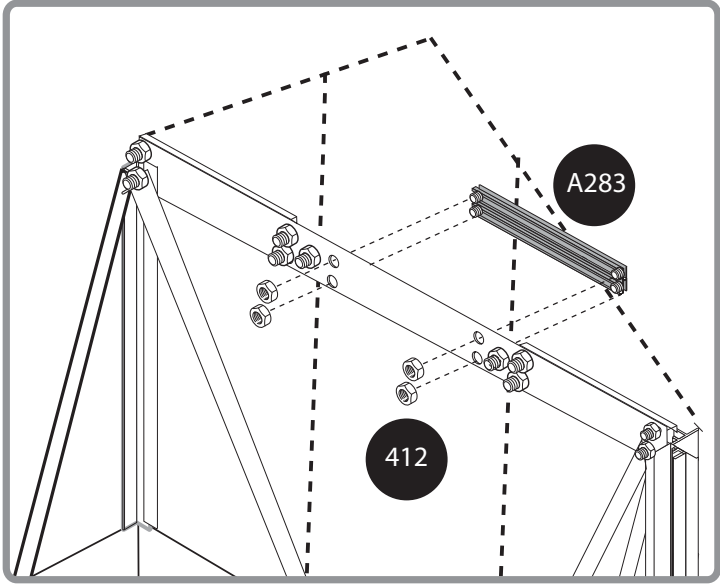
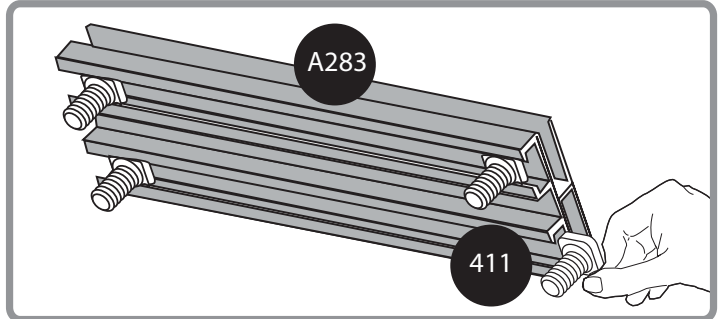
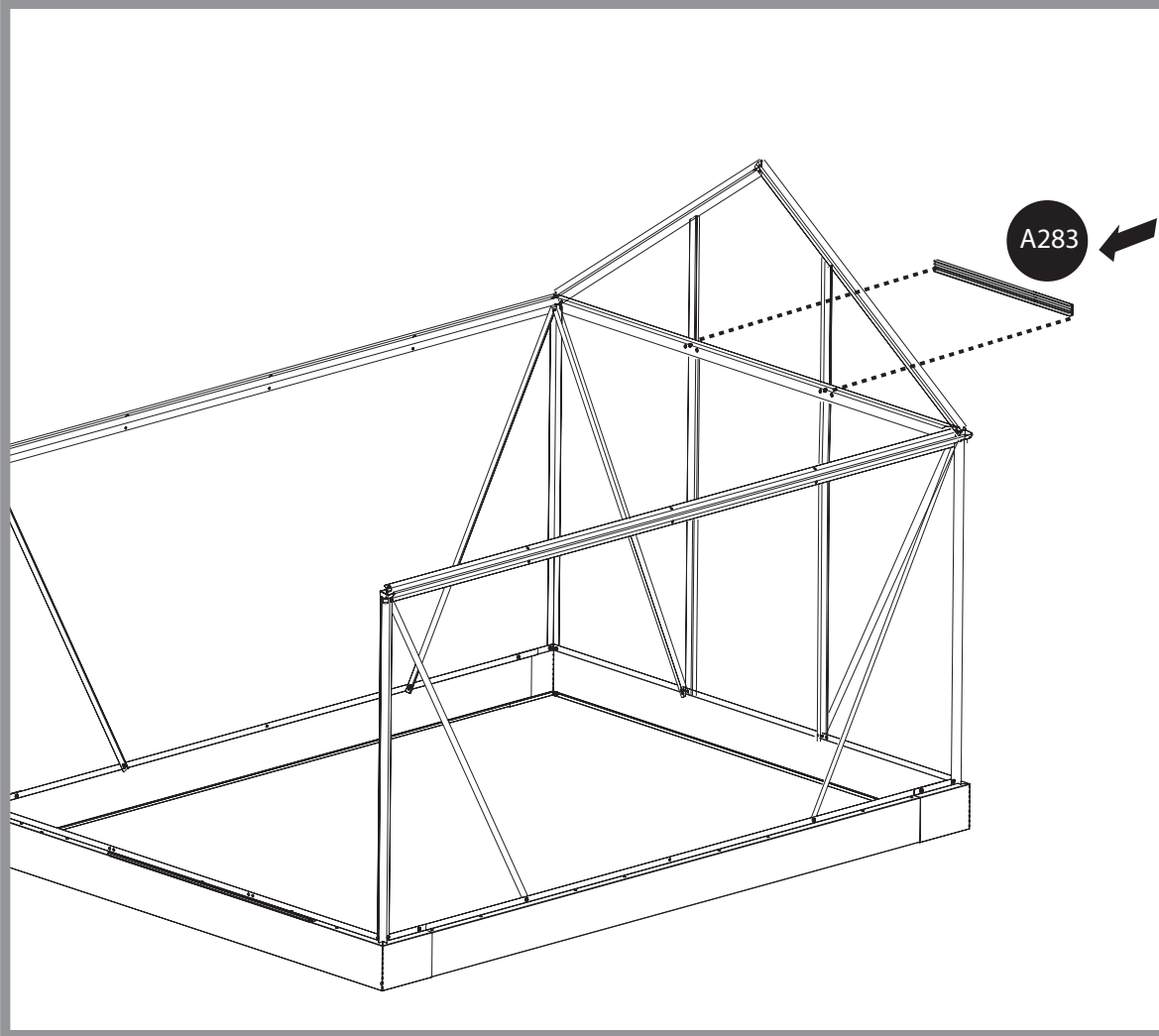
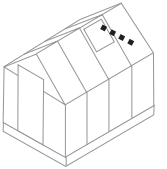

12

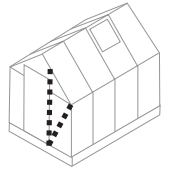

A256 x1

A203 x1

411 x1

412 x1

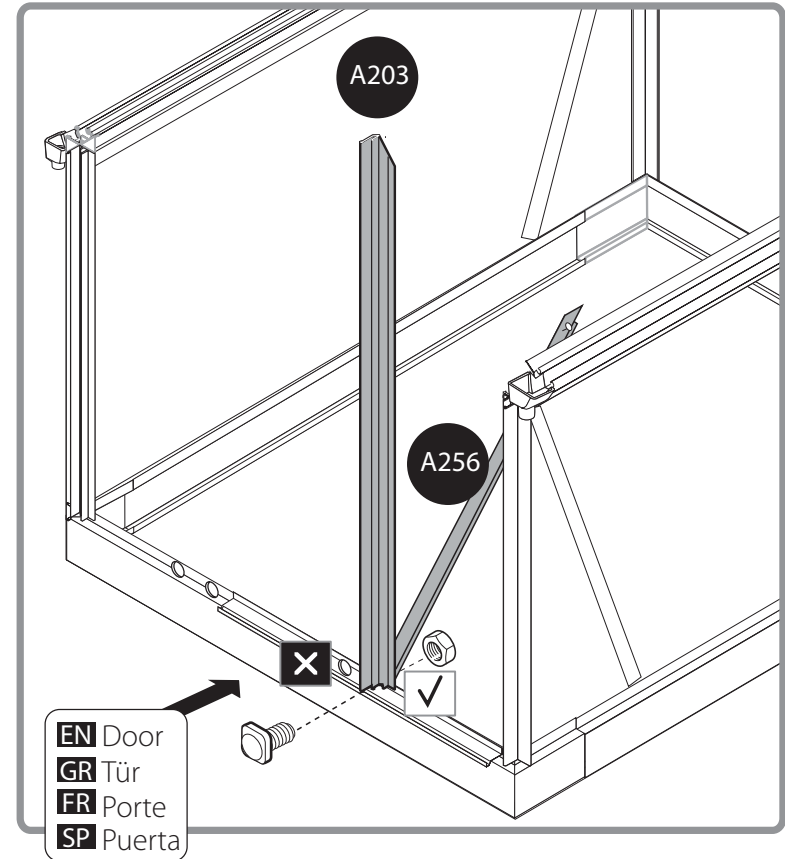
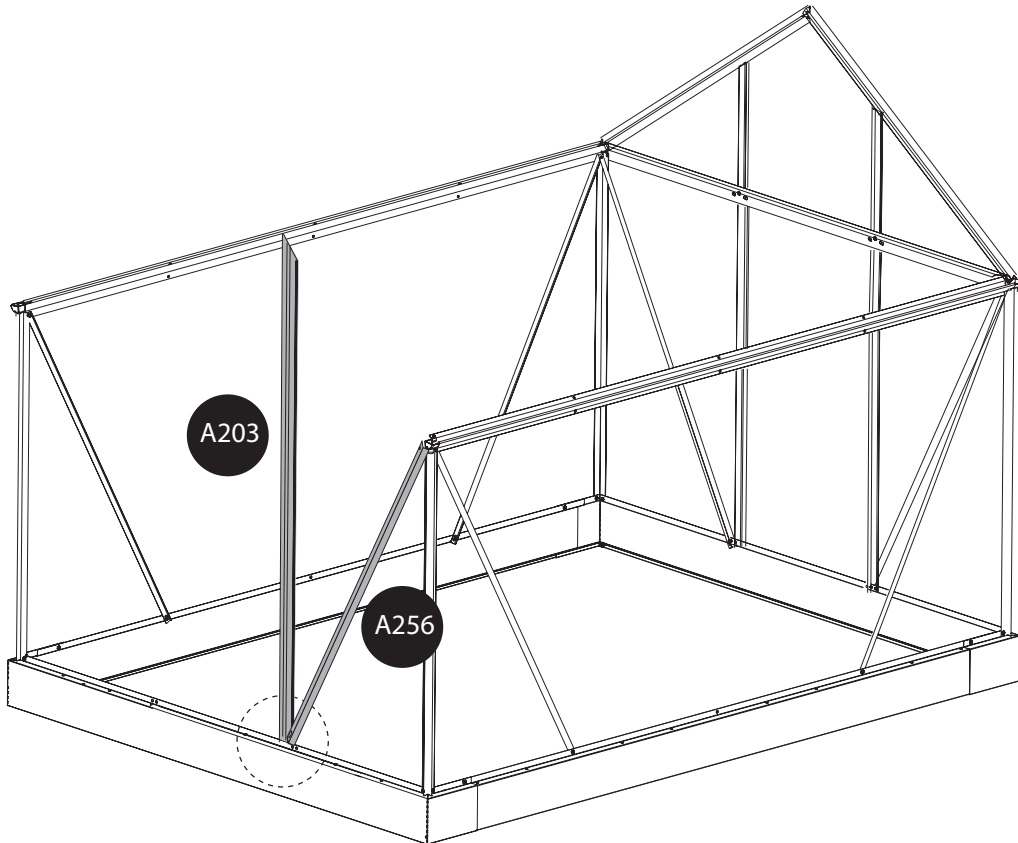

EN Door
GR Tür
FR Porte
SP Puerta

13

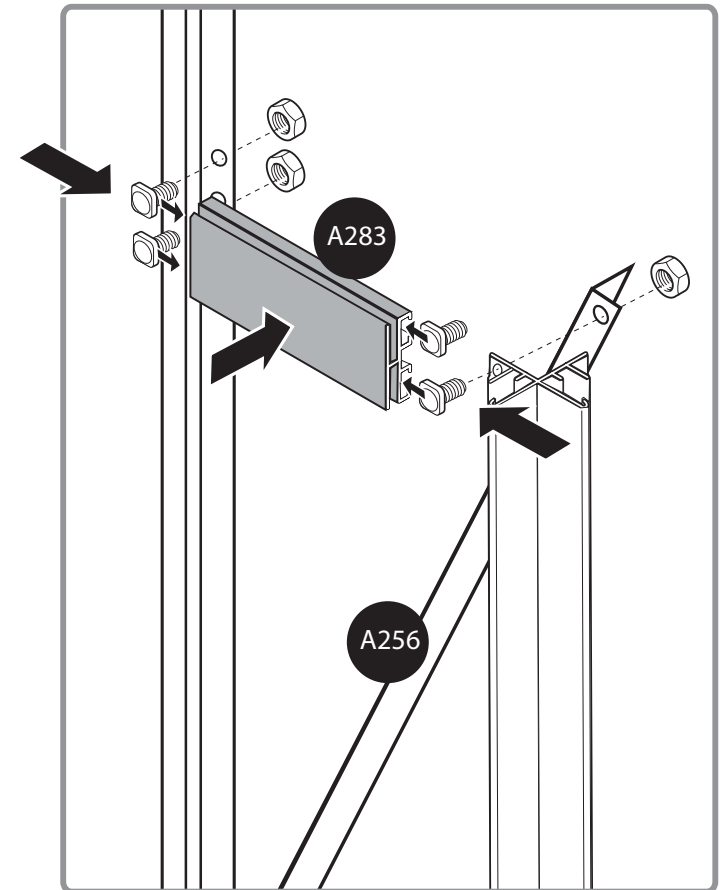
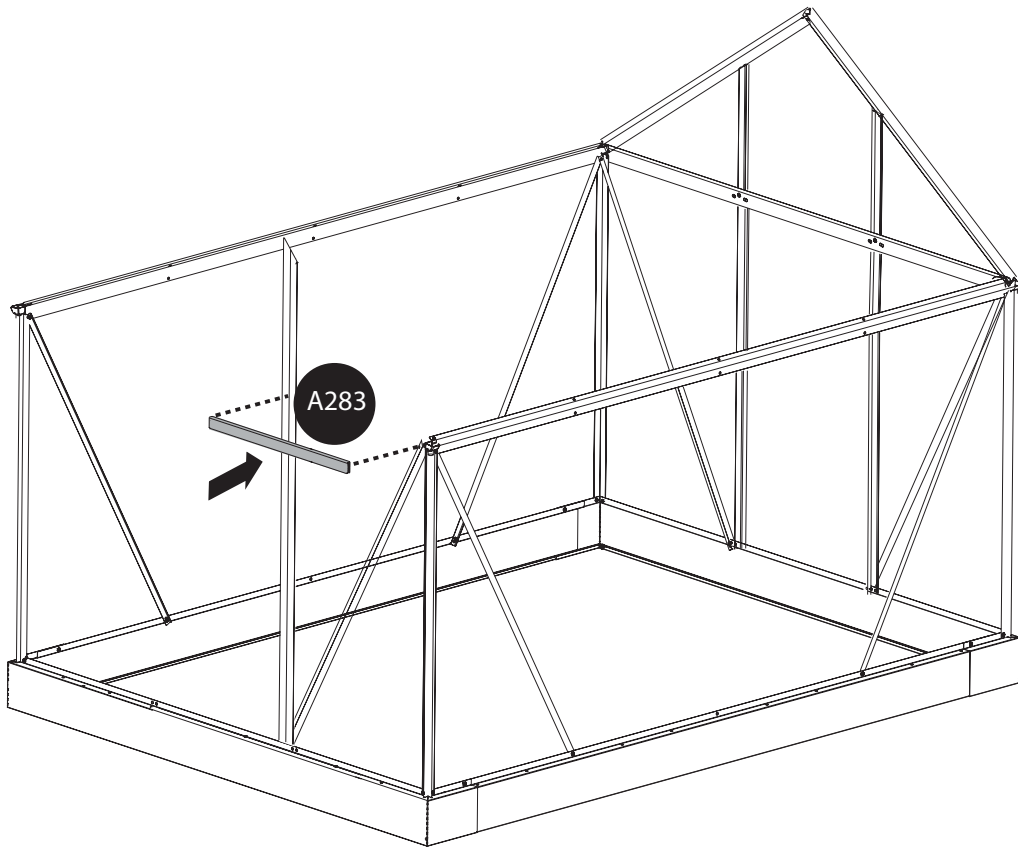
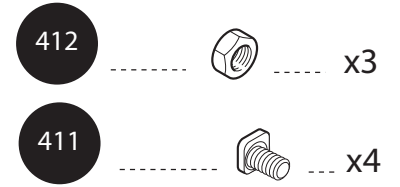
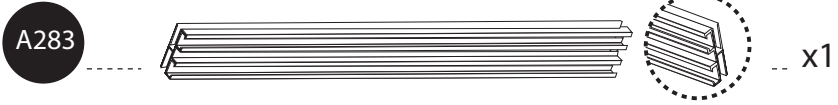
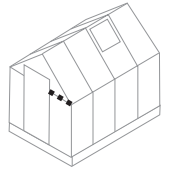

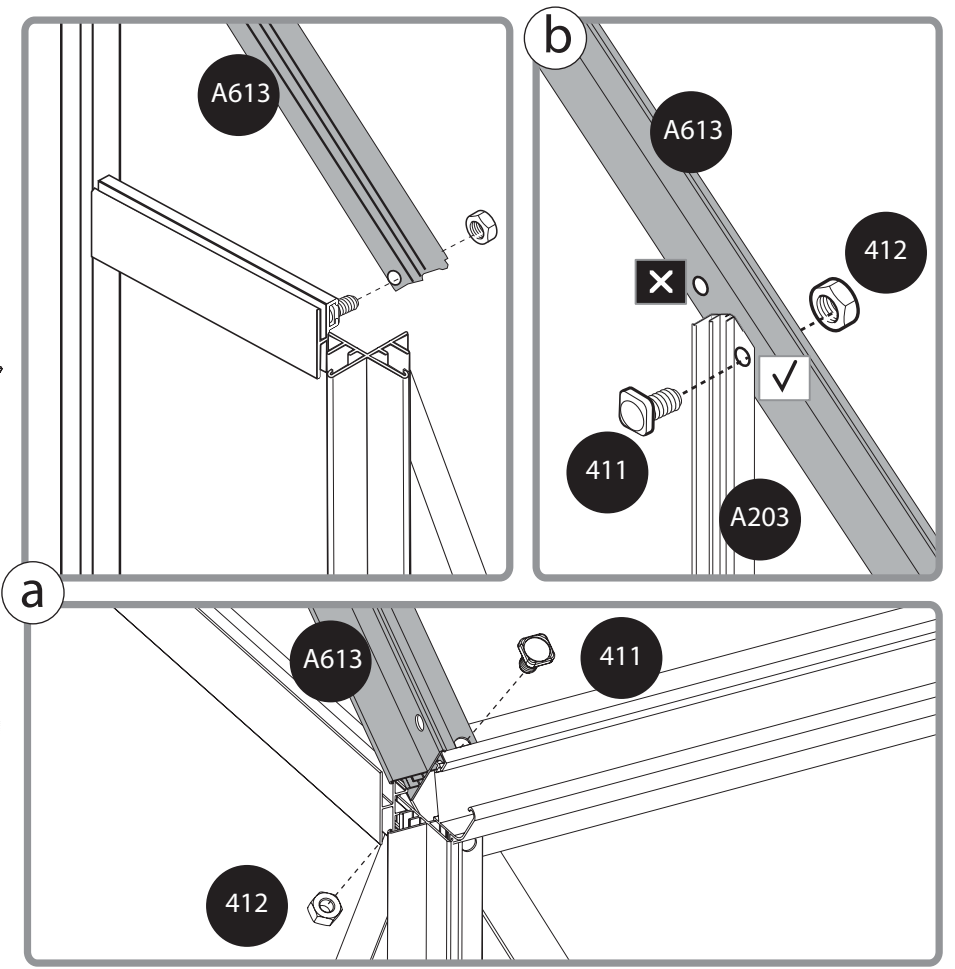
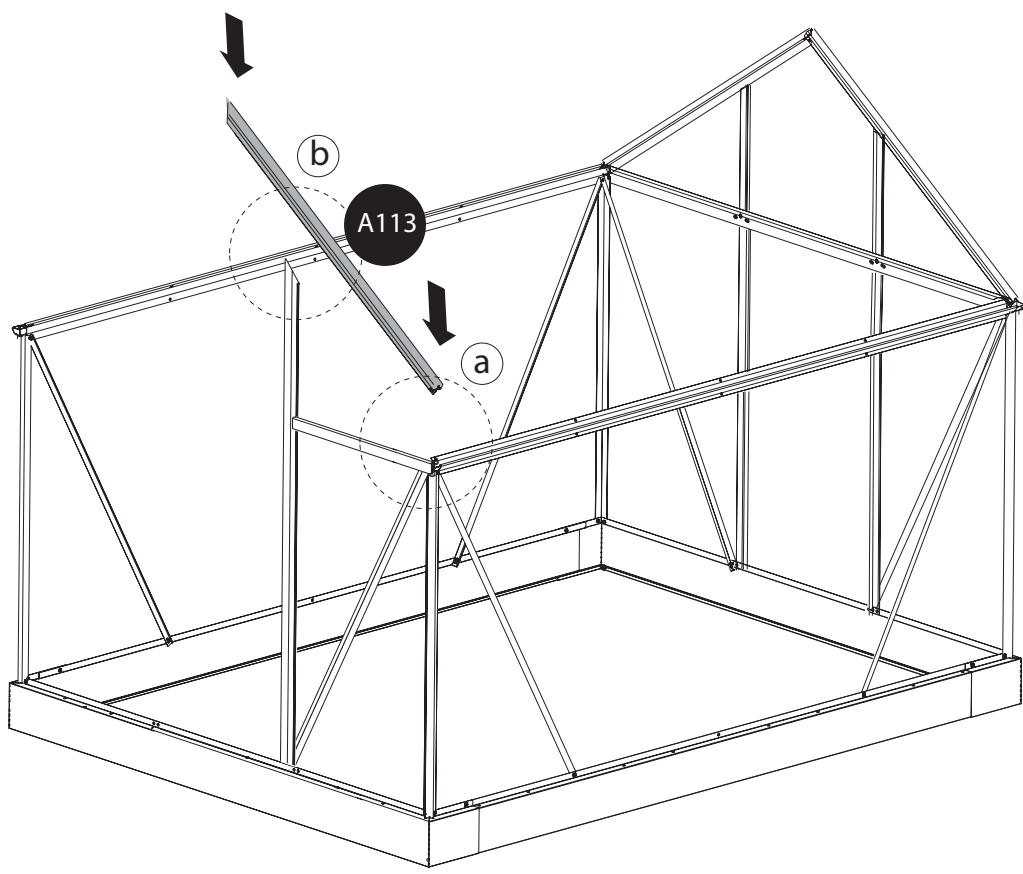
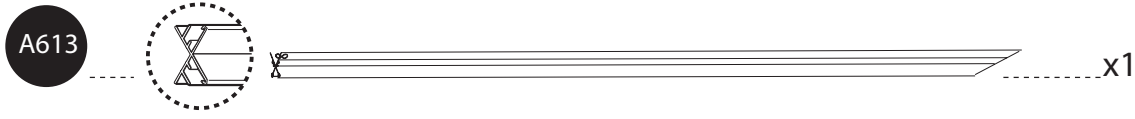
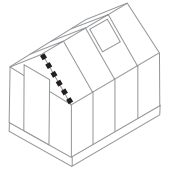

15

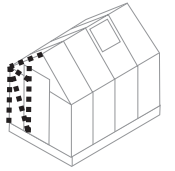

A256x1



A204x1

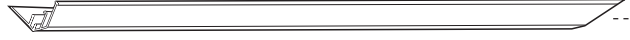

A114x1

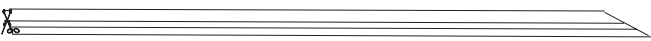

A283x1

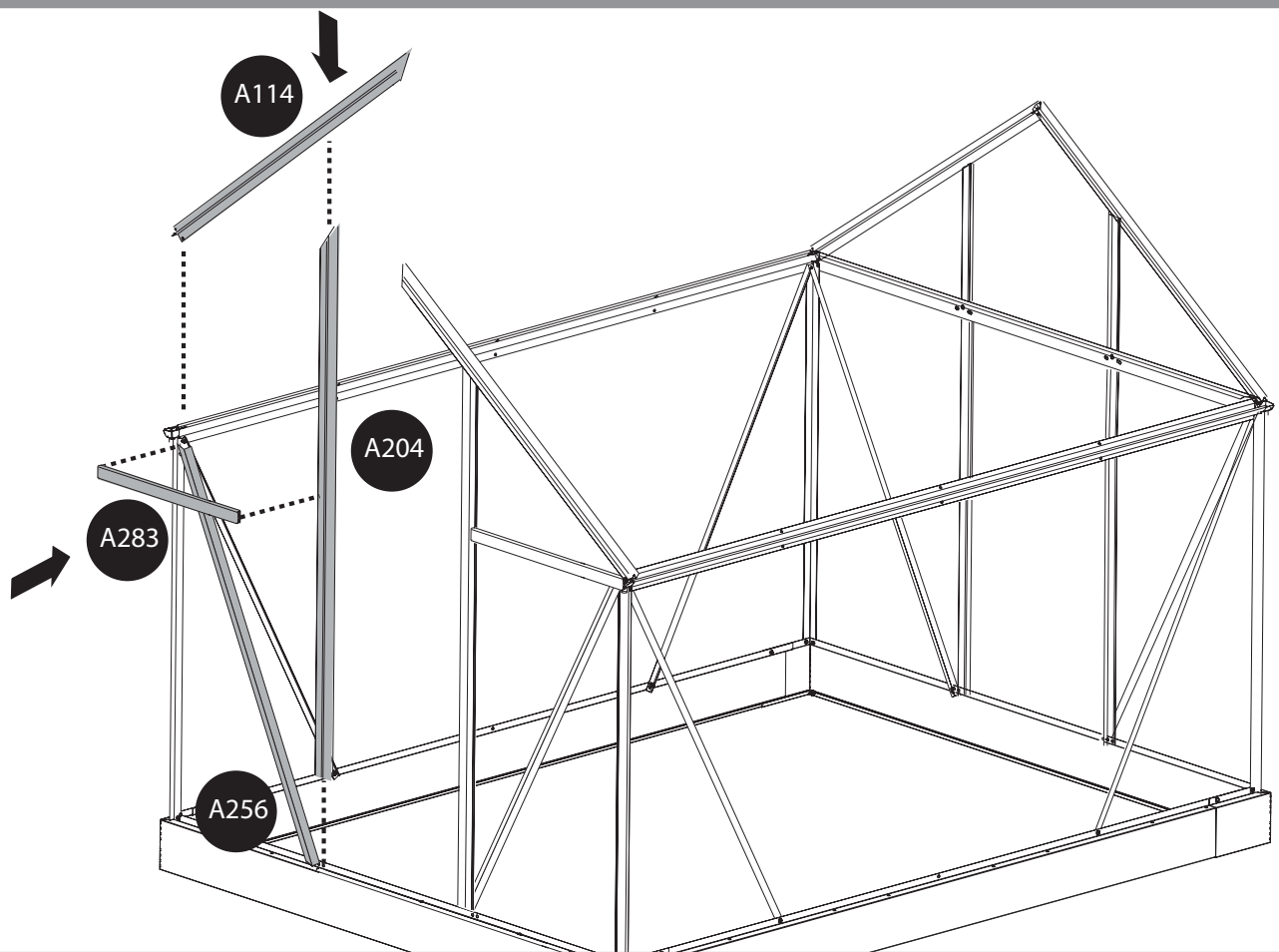
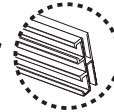

412x6



411x6



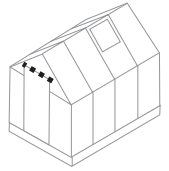

A211

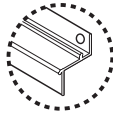

x1

411



x2

412



x2

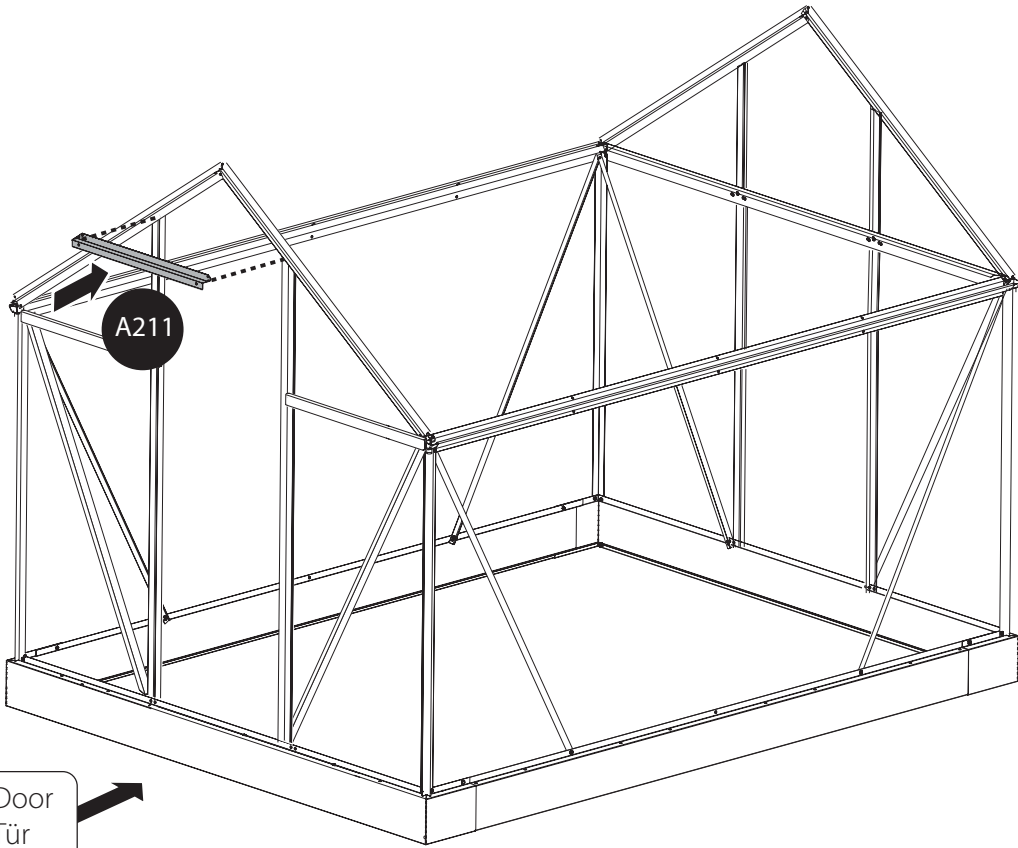

A211

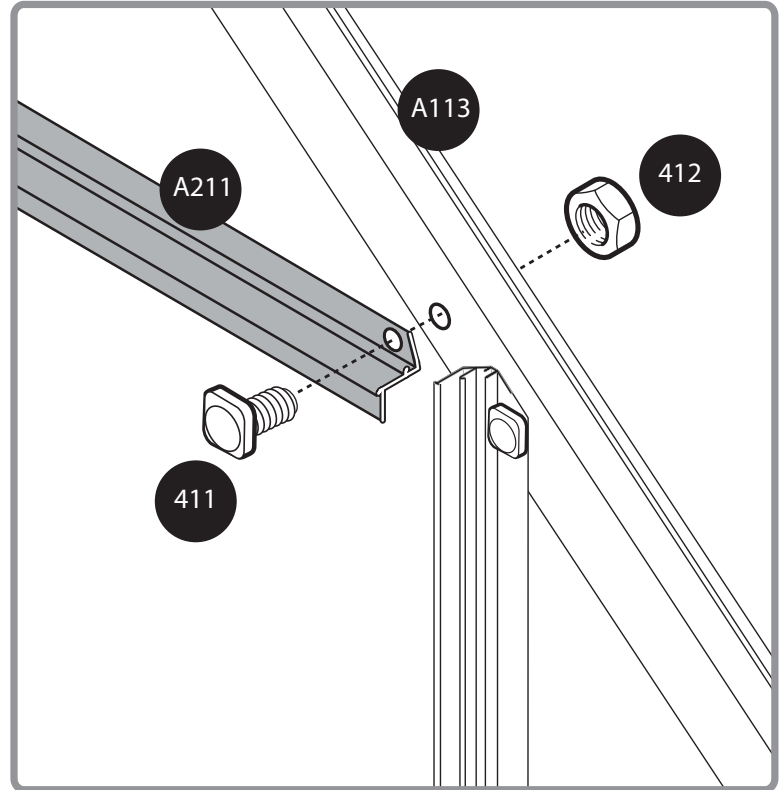

A113

A211

412

411

- EN** Door
- GR** Tür
- FR** Porte
- SP** Puerta

17

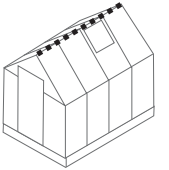

A141

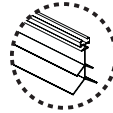
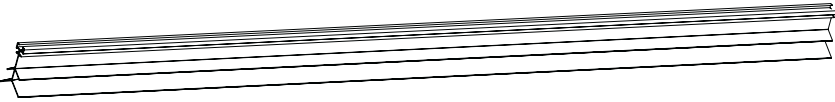

x1

412



x4

411



x4

A141

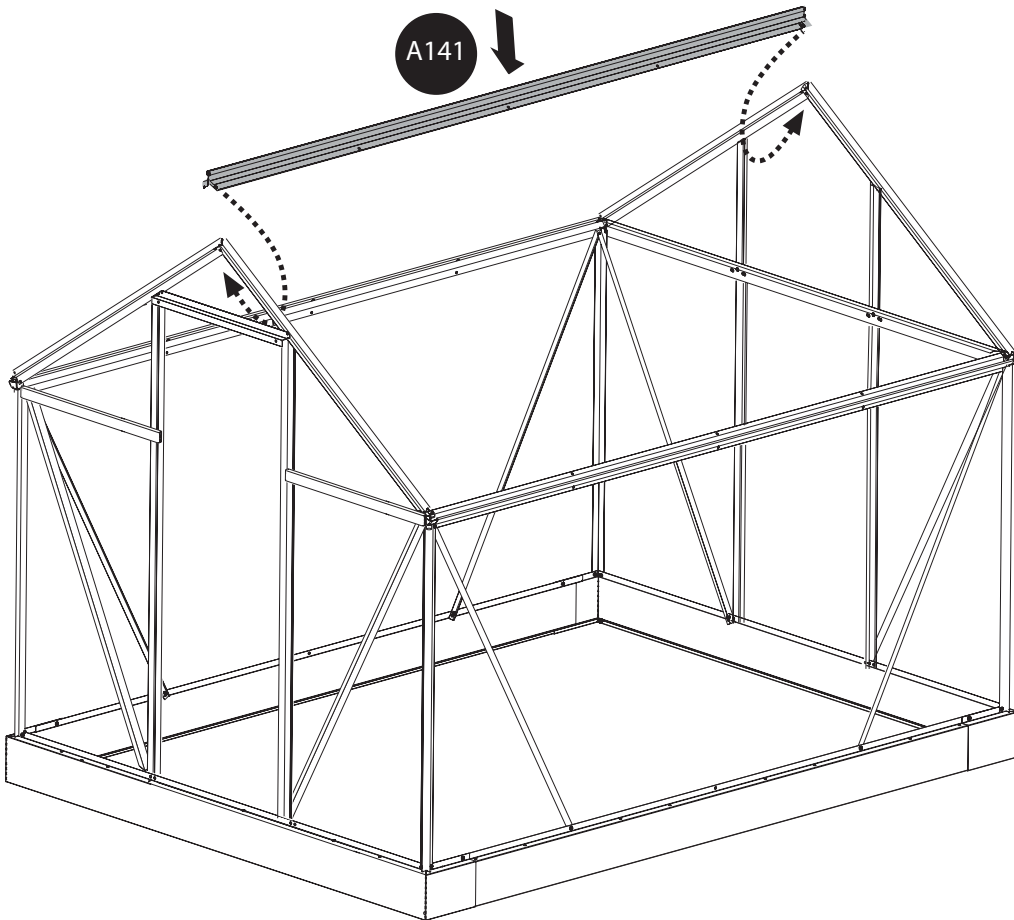

A141

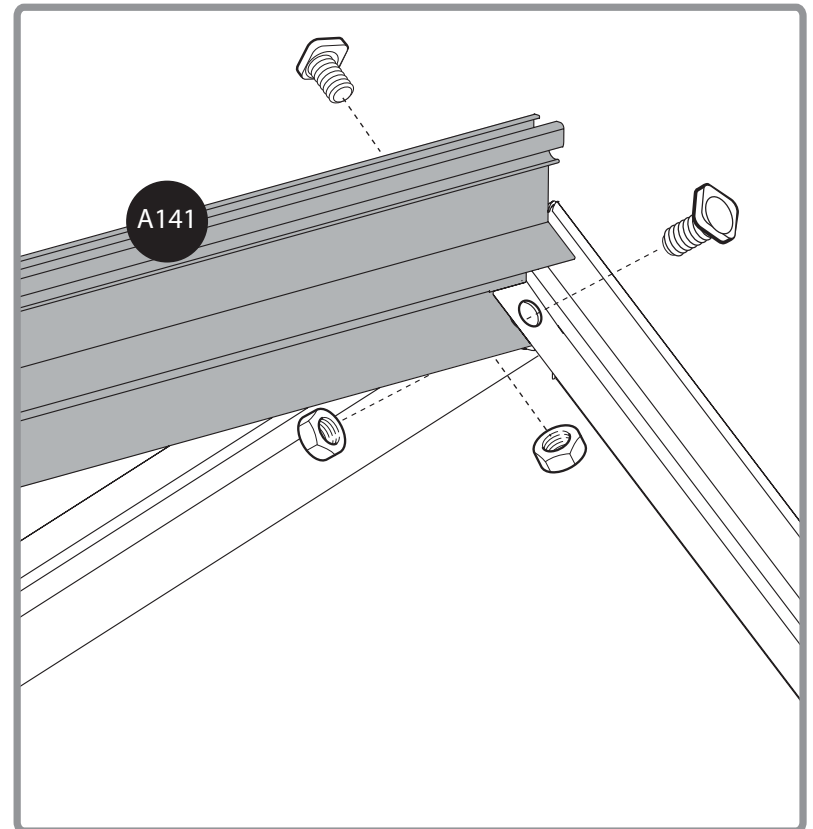

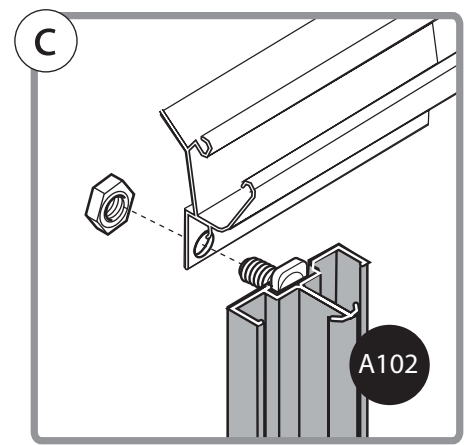
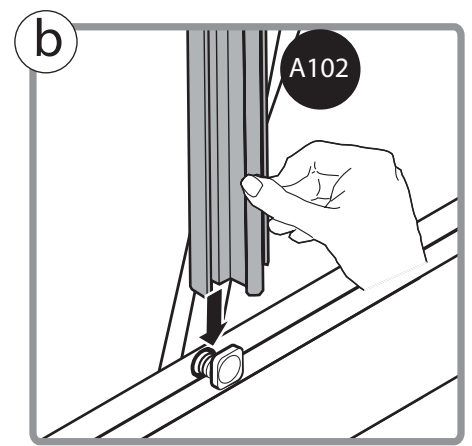
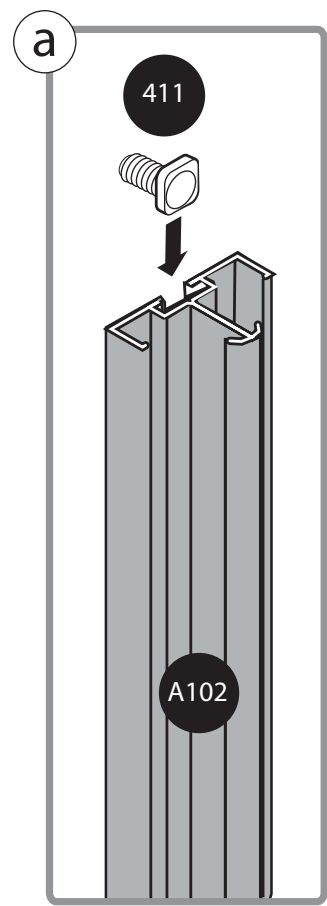
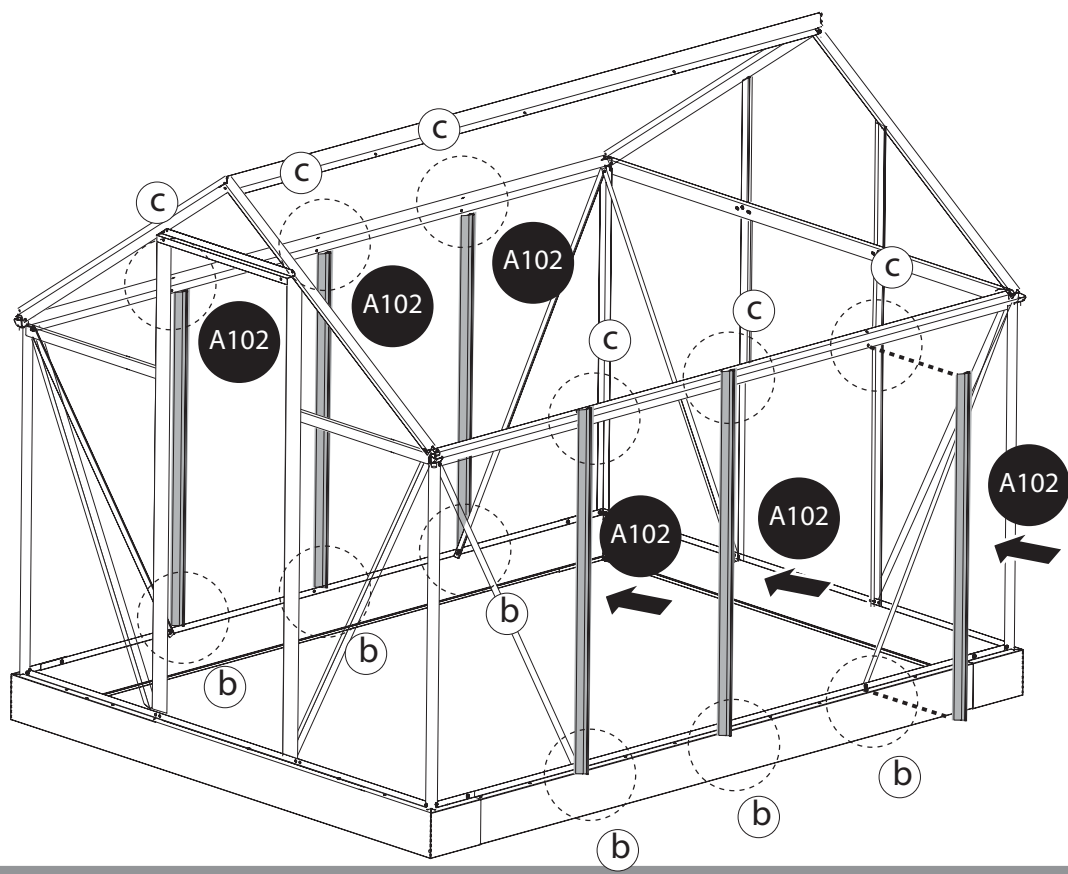
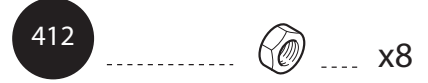
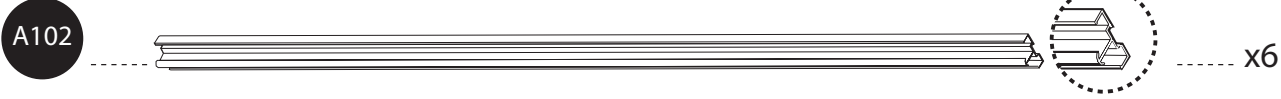
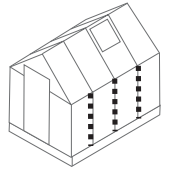

- EN Window Location
- GR Fenster Standort
- FR Fenêtre Emplacement
- SP Ventana Ubicación

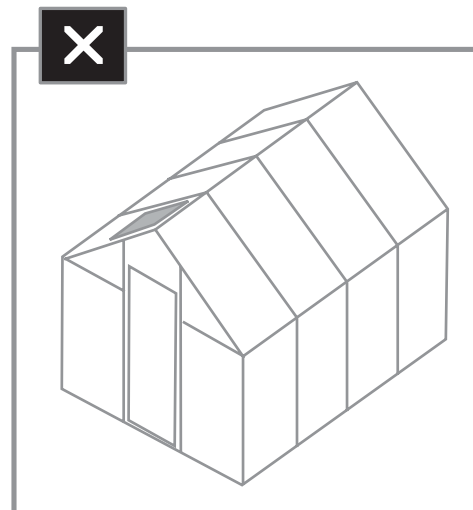
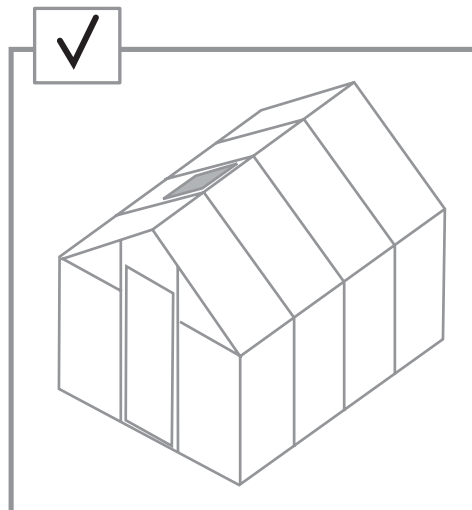
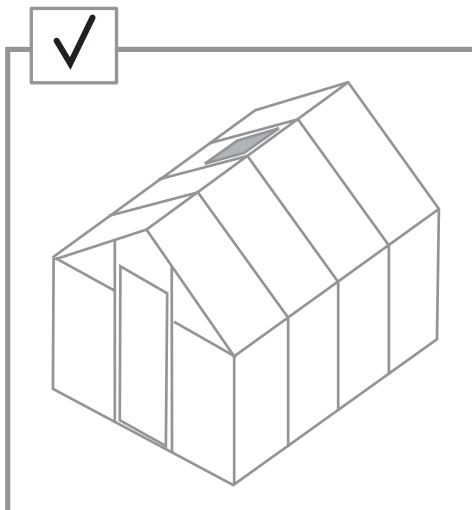
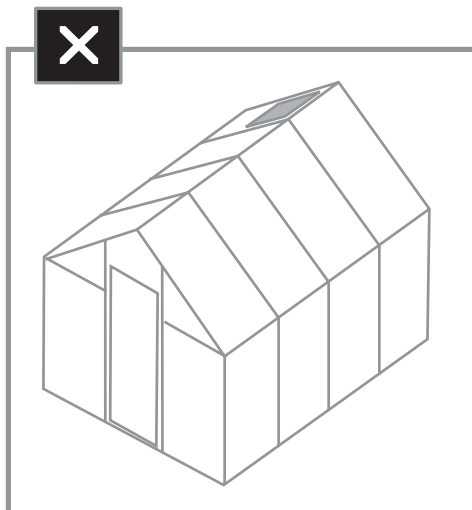
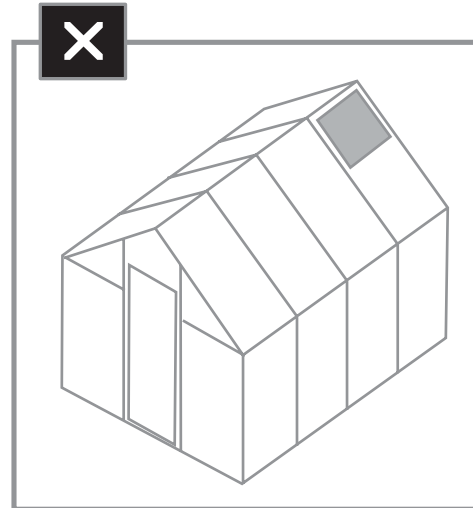
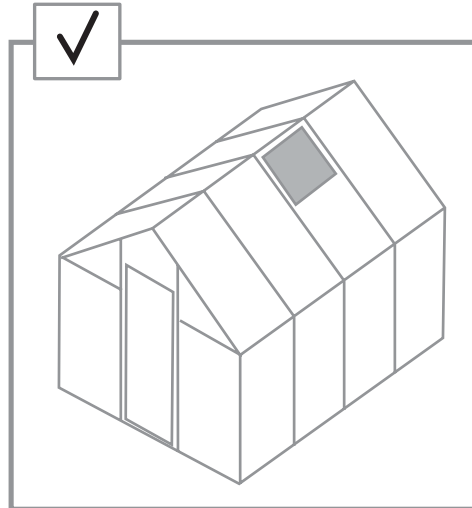
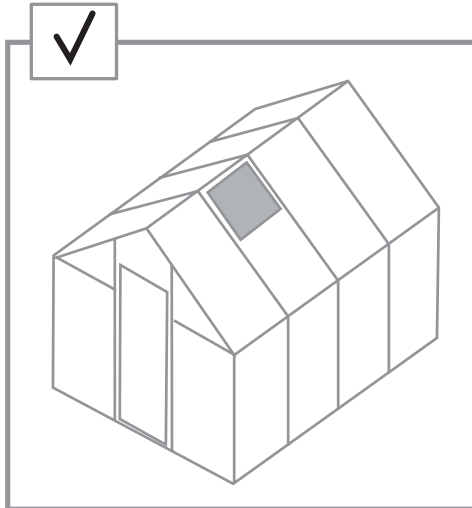
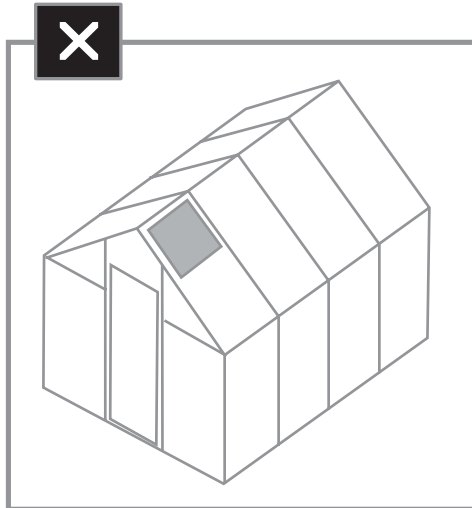
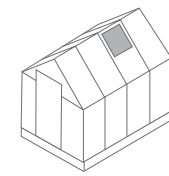

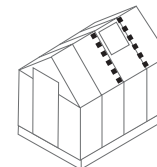

A102



x2

412



x4

411



x6

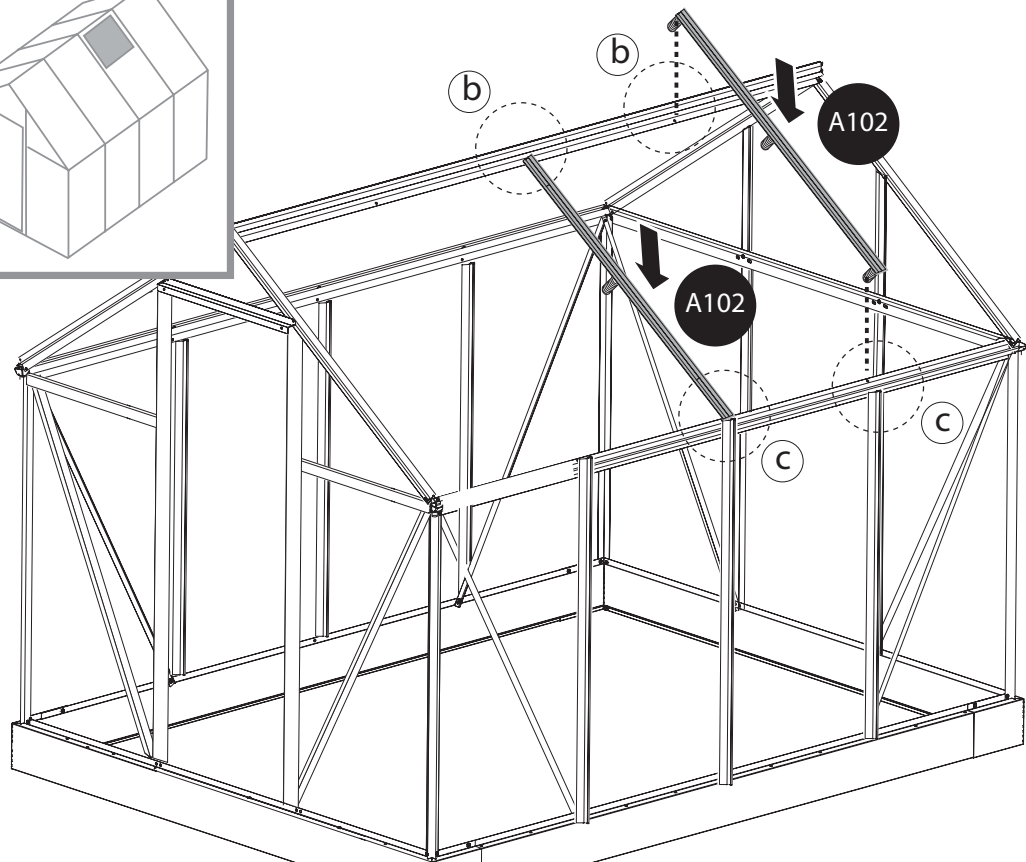
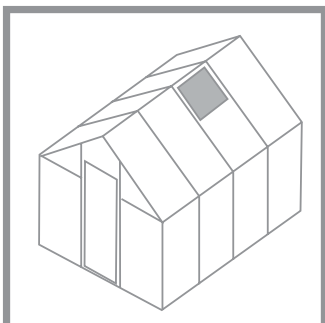

a

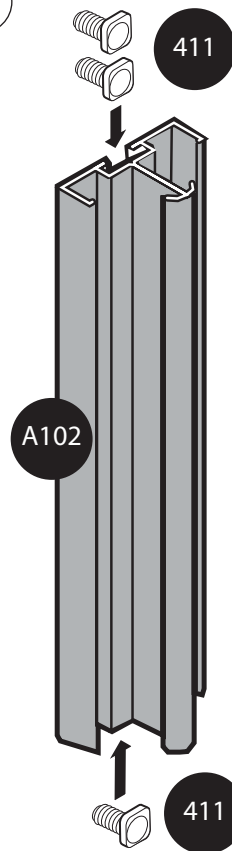

b

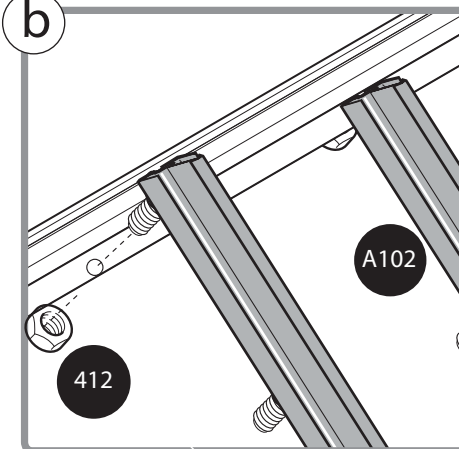

c

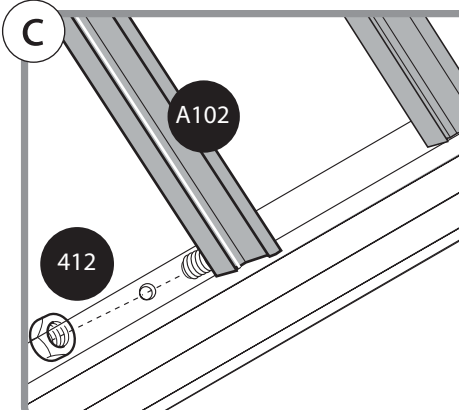

21

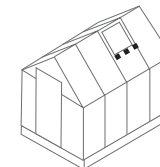
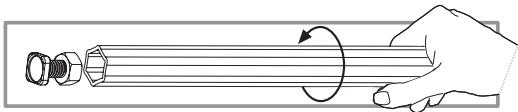

A260



412



x2

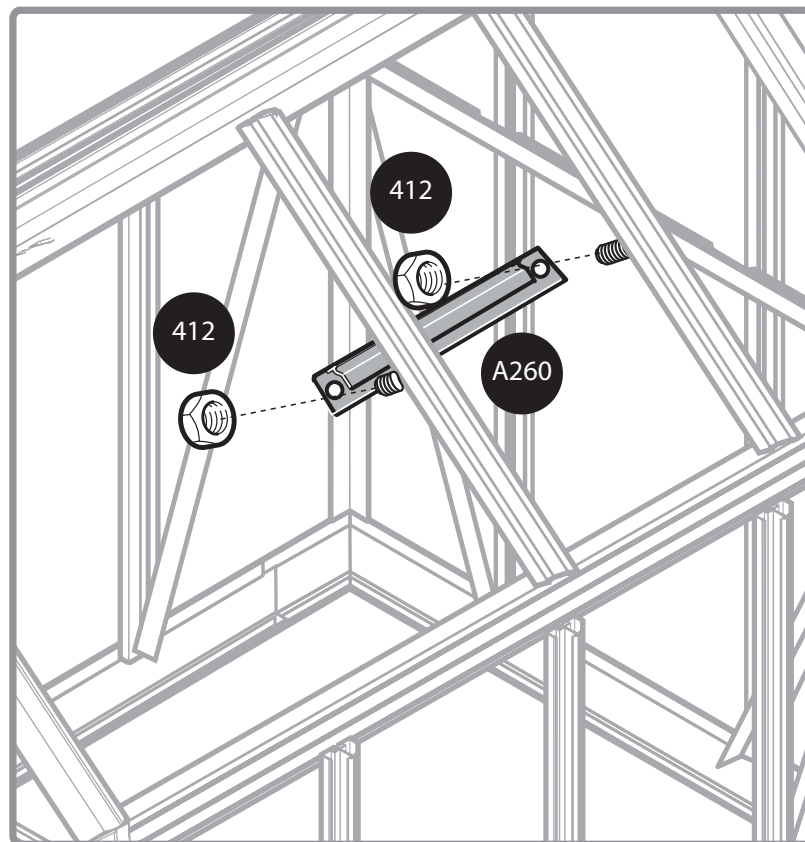
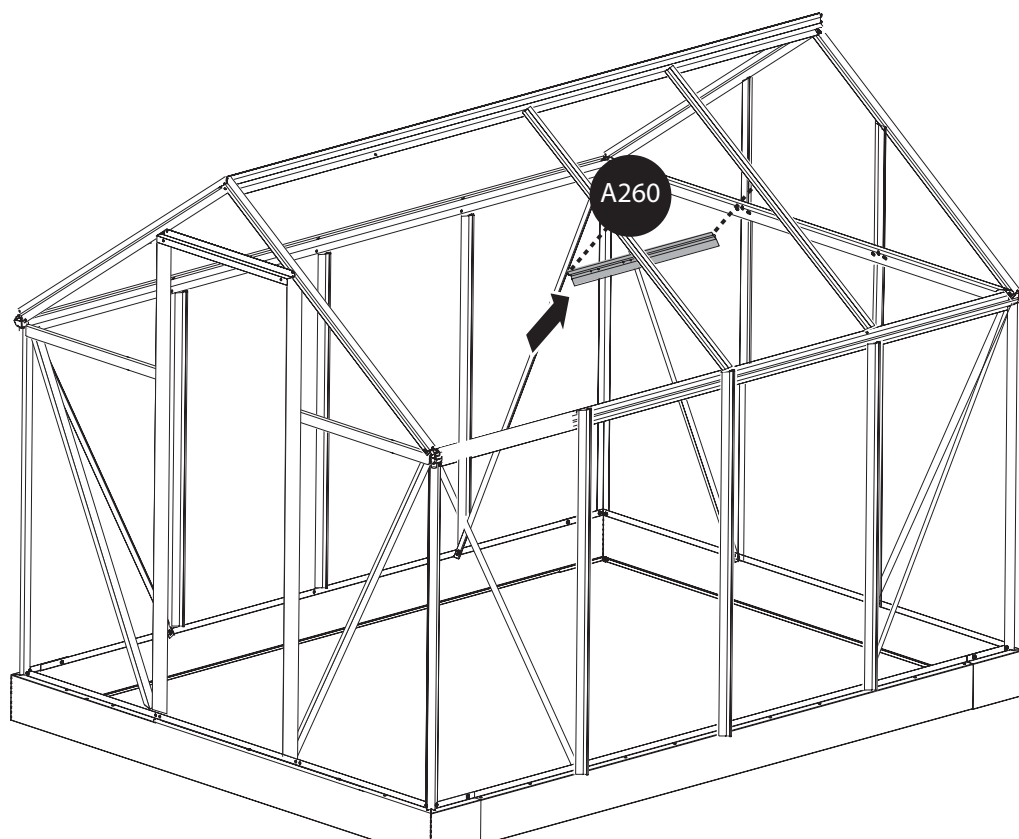

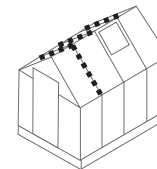

A102



x4

412



x8

411



x8

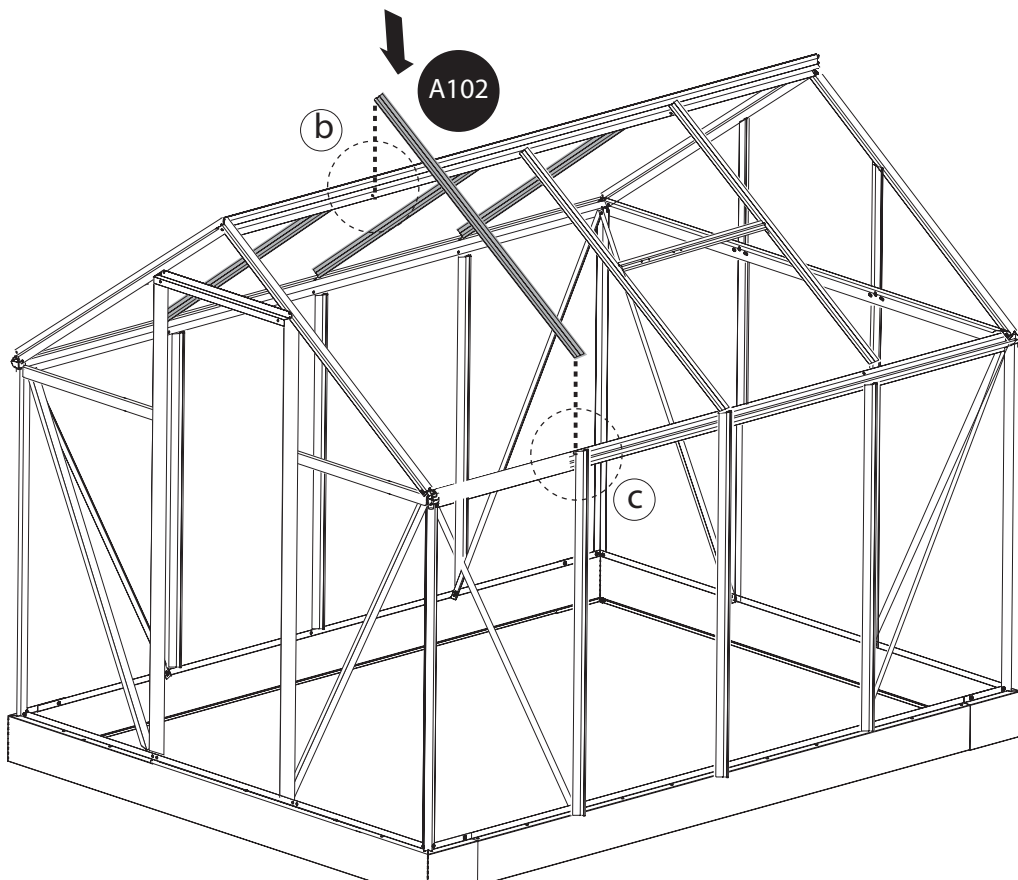

a

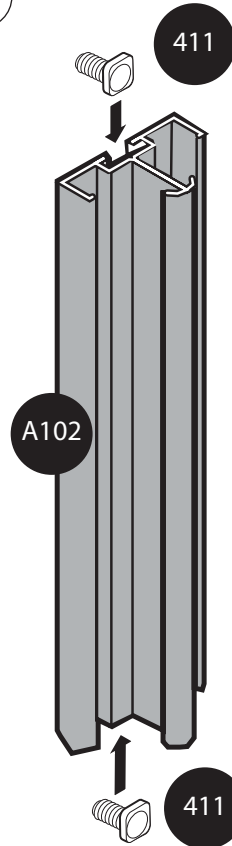

b

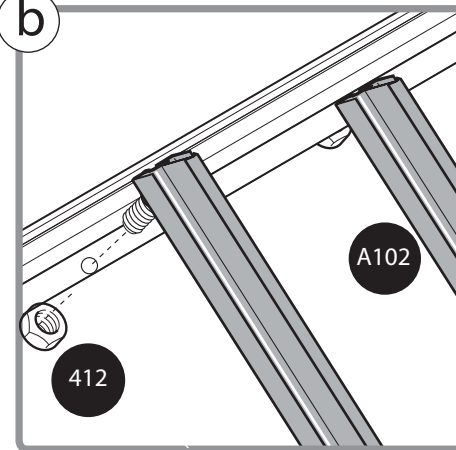

c

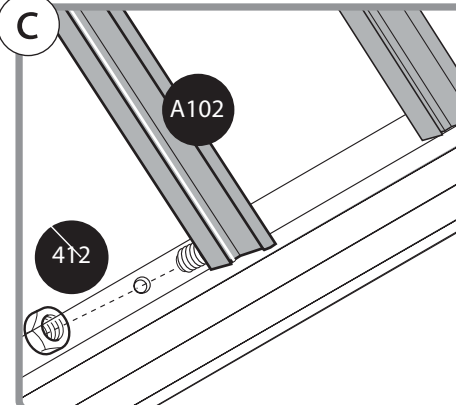

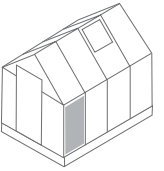

P540  x1

P328  x2

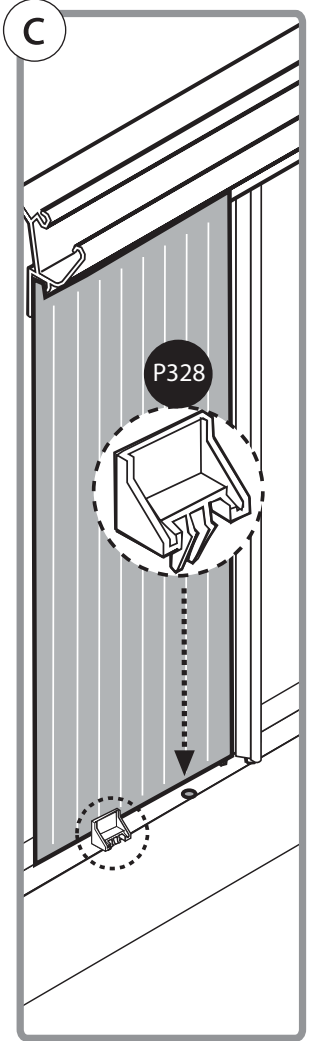
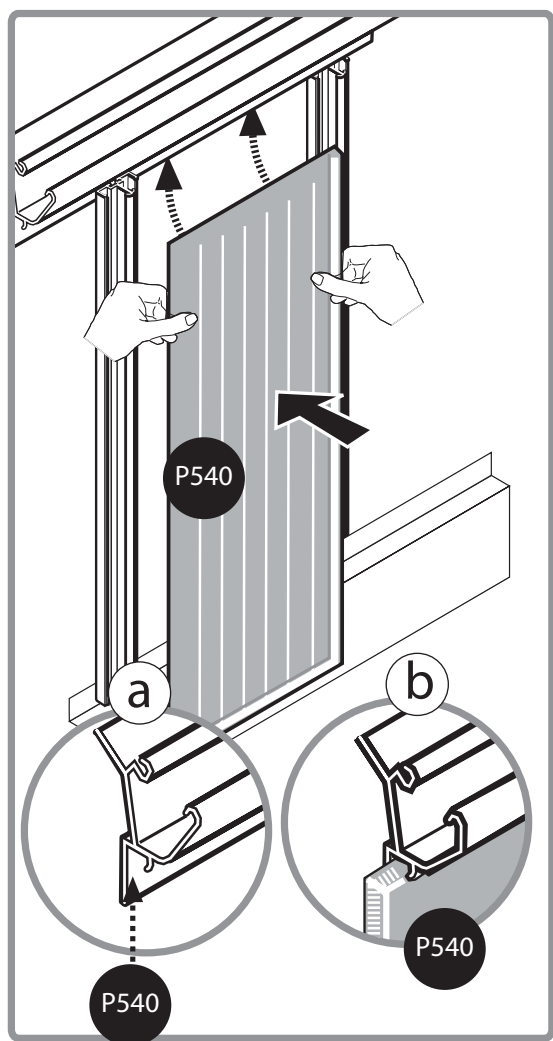
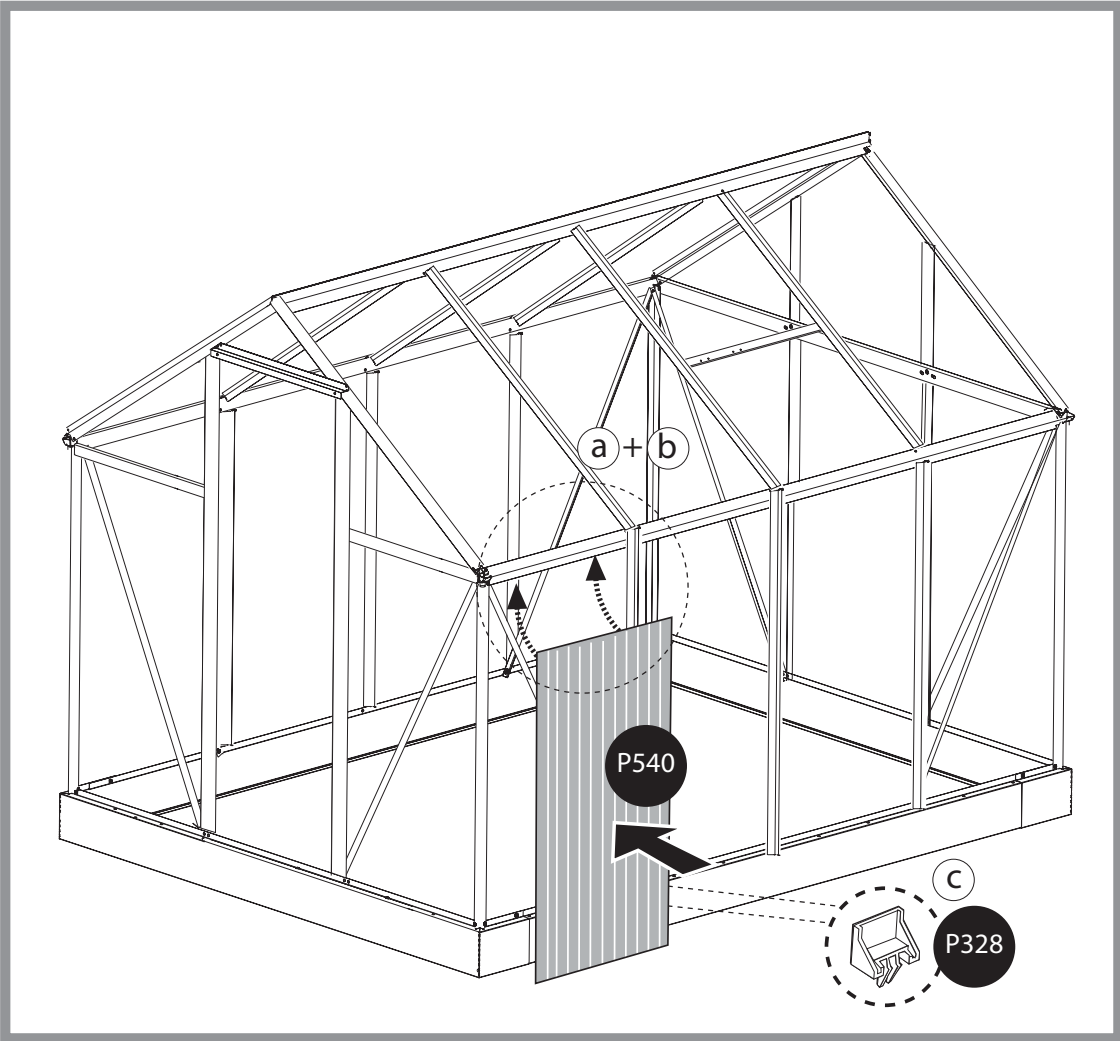

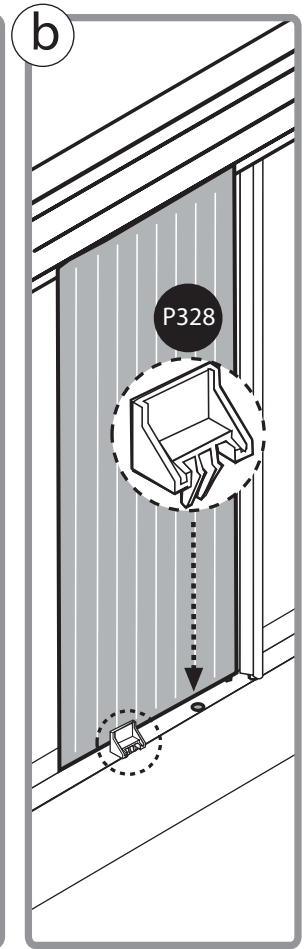
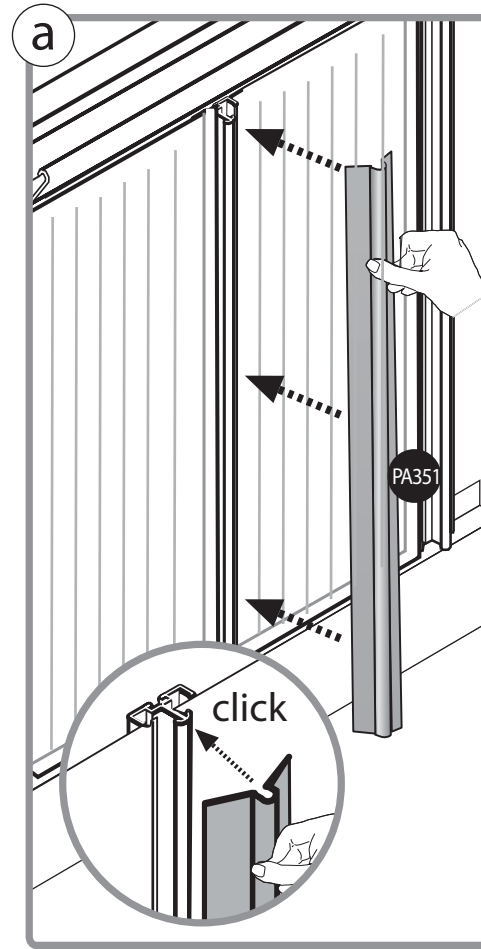
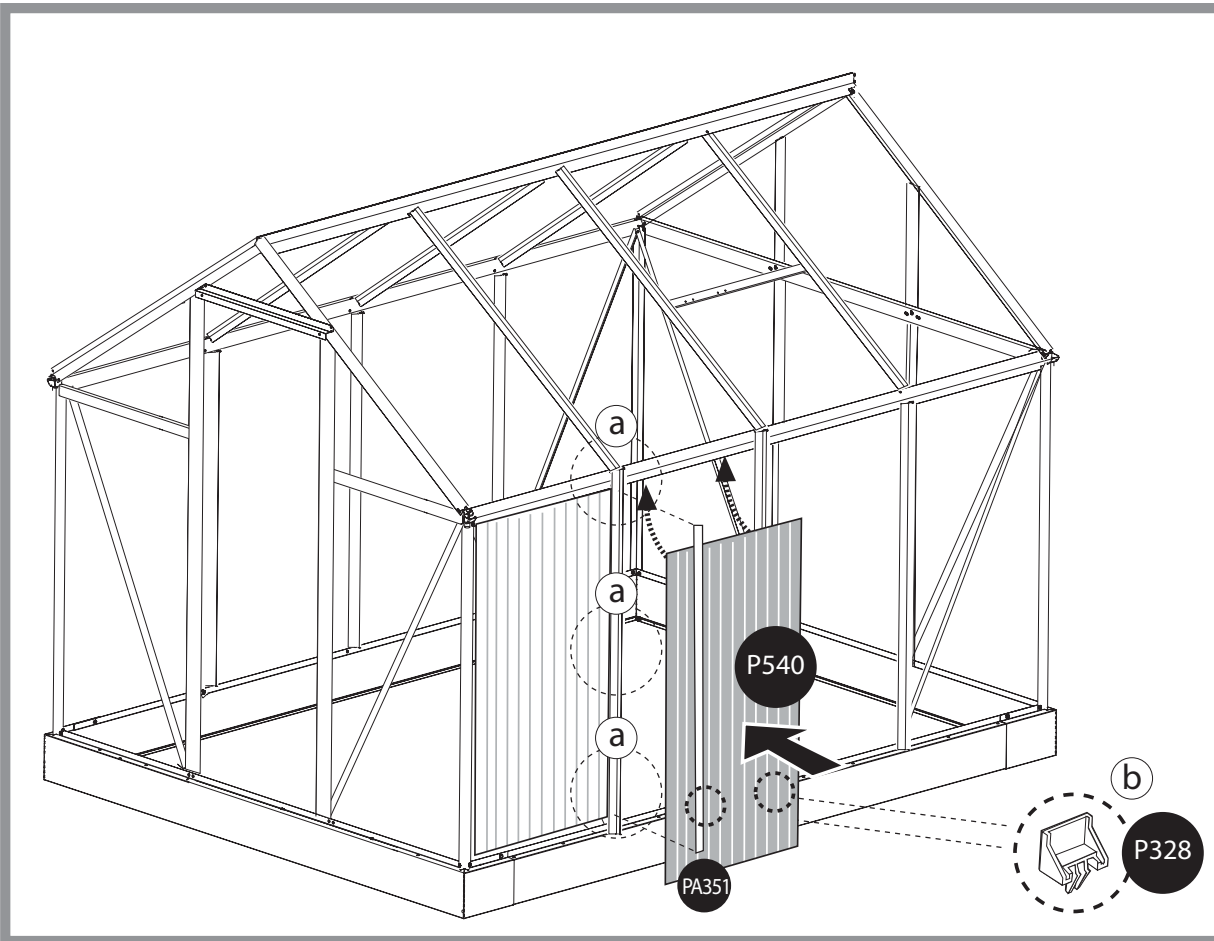
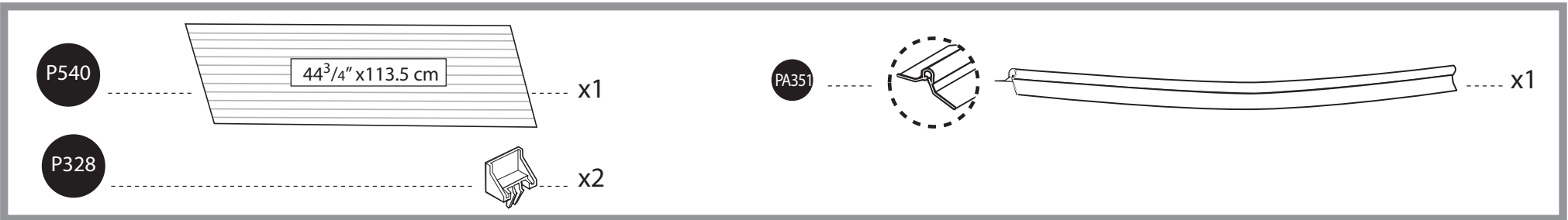
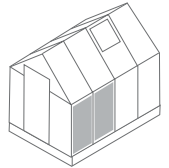

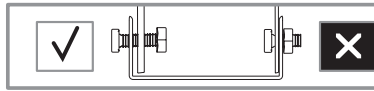

412



411

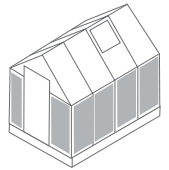

EN: Do not fix the next panel before the previous one is fixed with its sealing strip.

FR: Ne pas fixer le panneau suivant avant de prévisualiser le est fixe avec ses bandes d'étanchéité sur les deux côtés.

G: Don't fix das nächste Panel vor der Vorschau wird ein fest mit seinen Dichtleisten auf beiden Seiten.

SP: No fijar el panel siguiente, antes de la vista previa es fijo con sus franjas de protección en ambos lados.

IT: Non fissare il pannello successivo prima di quello anteprima è fissa con le sue fasce di tenuta su entrambi i lati.

NL: Niet de volgende paneel vast te stellen voordat de previews is een vastgezet met de sluiting ervan, strips aan beide zijden.

SW: Don't fix nästa panelen innan förhandsvisningarna en är fast med tätningslister på båda sidor.

DA: Du må ikke lave den næste panel før previews ene er fast med tætninglister på begge sider.

FI: Älä korjaa seuraavan paneelin ennen previews yksi Kiinteä sen sulkemiseen kaistaleina molemmin puolin.

CZ: Don't fix vedle panelu pred náhledy z nich je Pevná s tesnicí pásky na obou stranách.

SL: Nechcem fix vedla panela pred náhladov z nich je Pevná s tesniace pásky na oboch stranách.

POL: Nie ustala następnym przed rokiem, podgląd jest stalych z tasmę uszczelniające z obu stron.

RO: A nu se fixeze la panoul de lângă înainte de a previews unul este fix cu benzi de sigilare, pe ambele fețe.

NO: kke fest neste panel før forhåndsvisninger ene er fast med tetningslister på begge sider.

POR: Não fixar o painel seguinte, antes de uma amostra é fixada com suas tiras de vedação em ambos os lados.

SLOV: Ne dolocajo naslednji plo•ci, preden je ena predogledi doloceno s svojo zapiranj trakova na obeh straneh.

P540

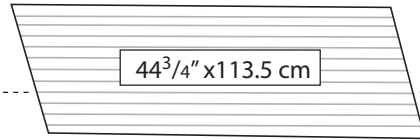

x11

PA351



x7

P328



x22

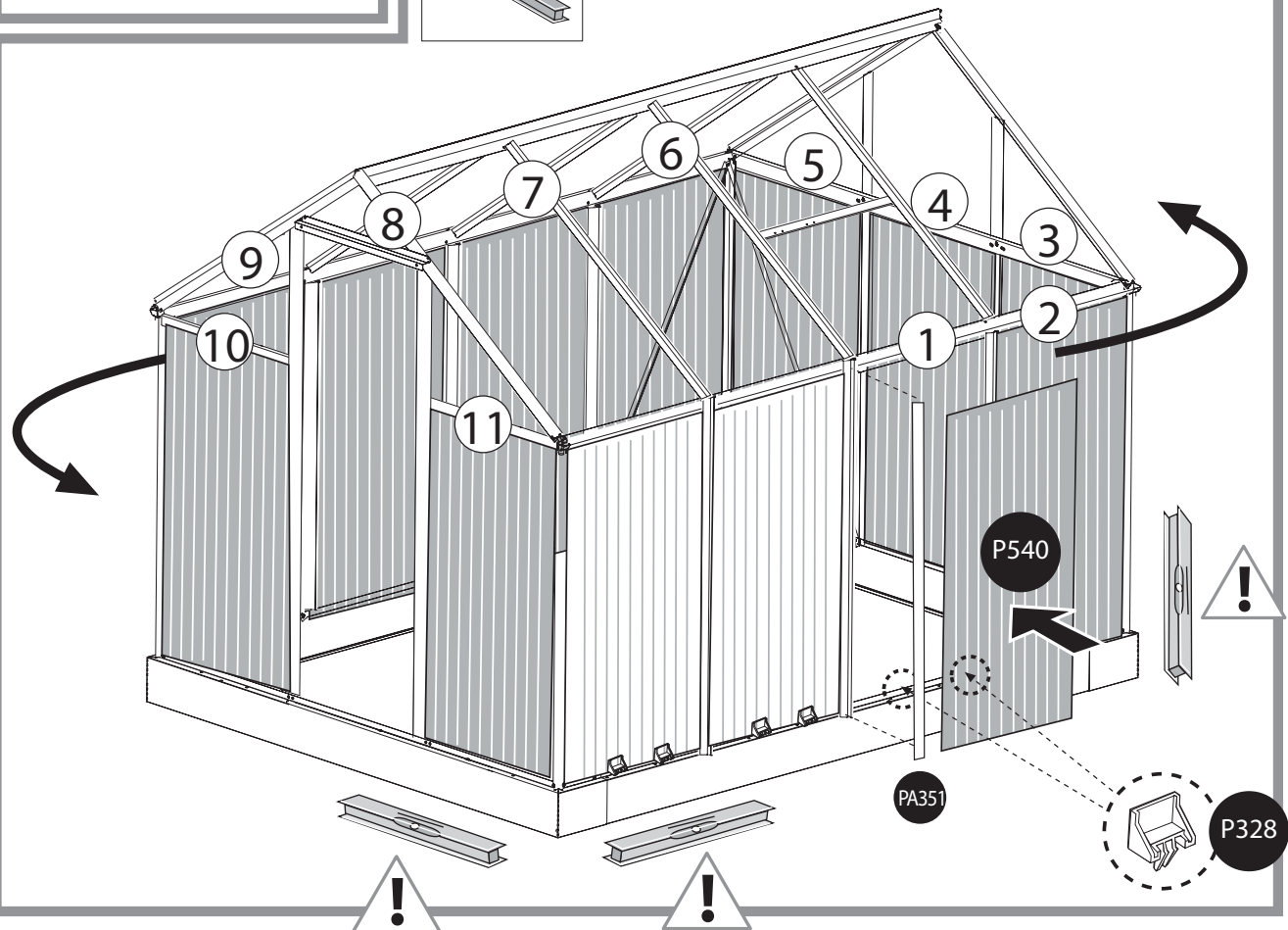
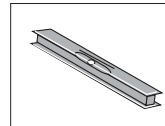

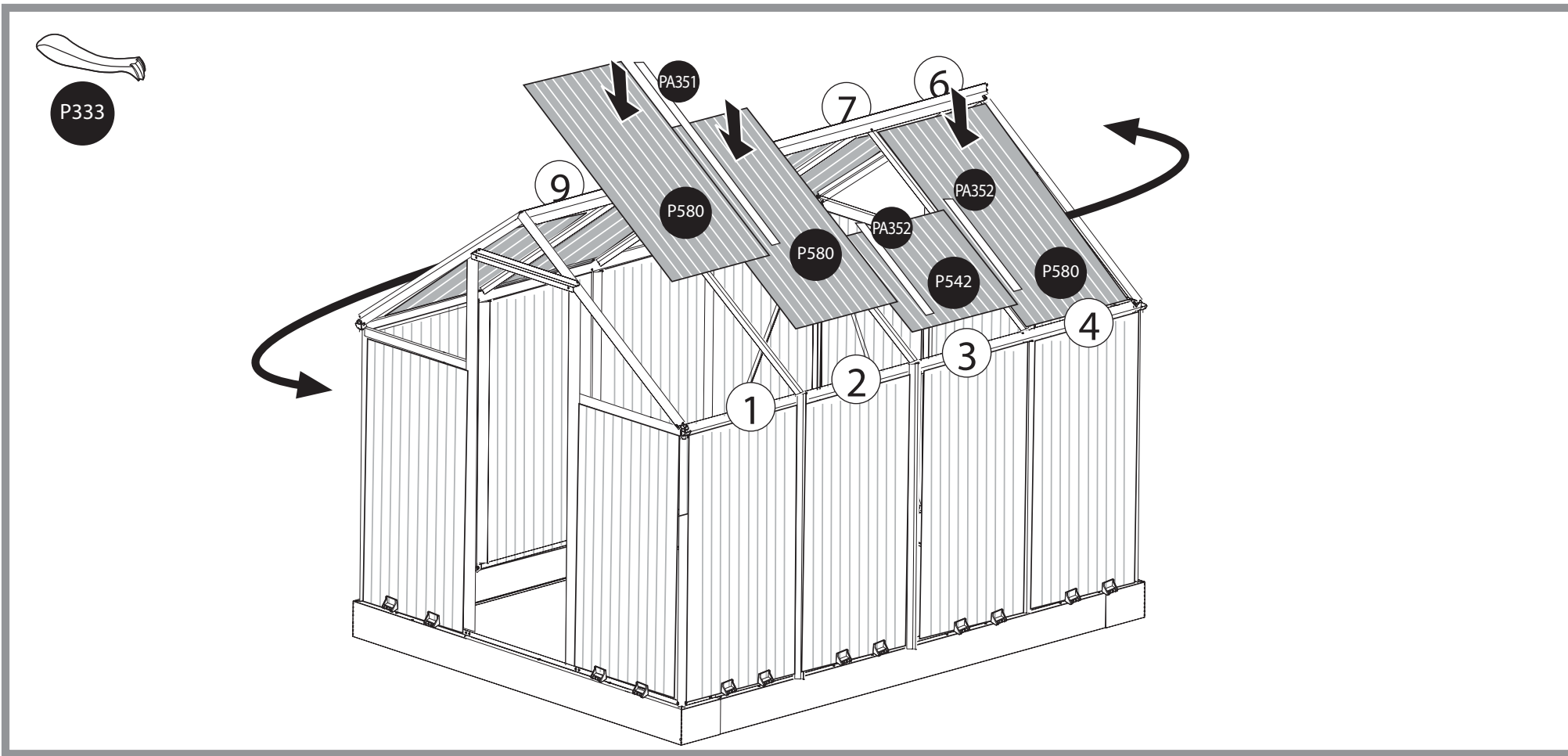
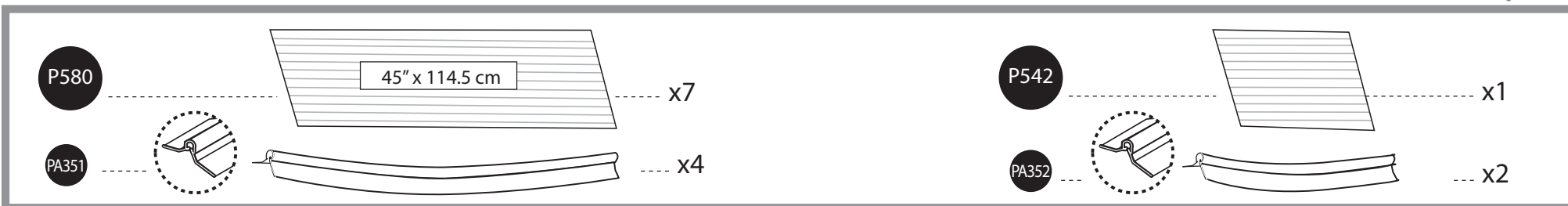
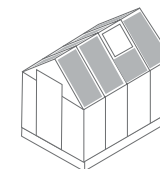

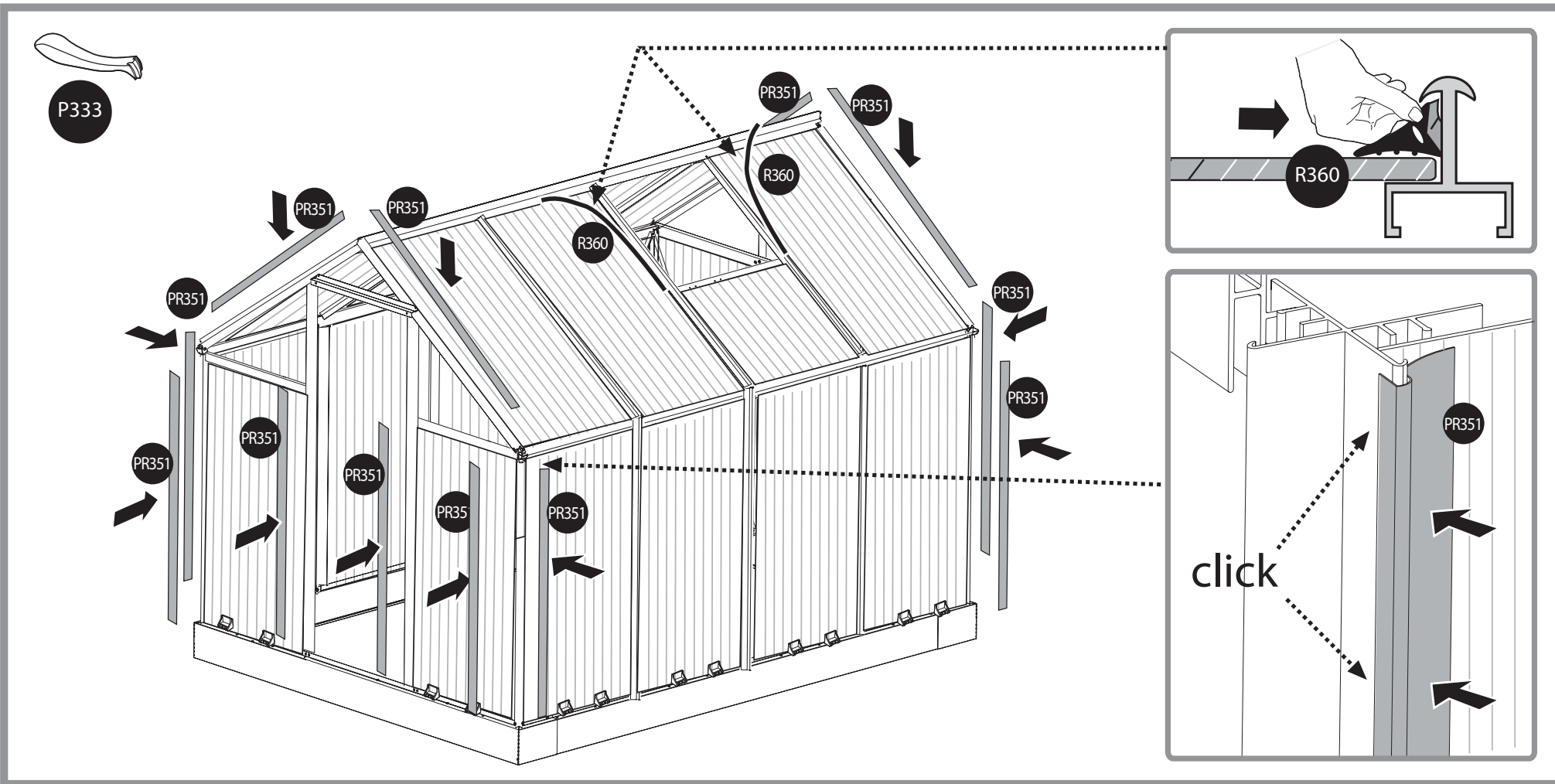
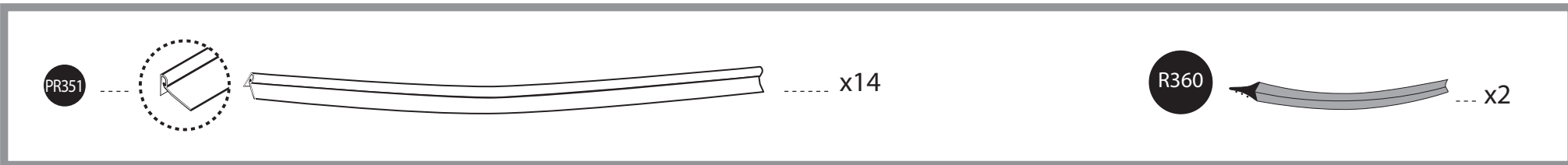
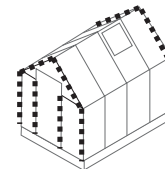

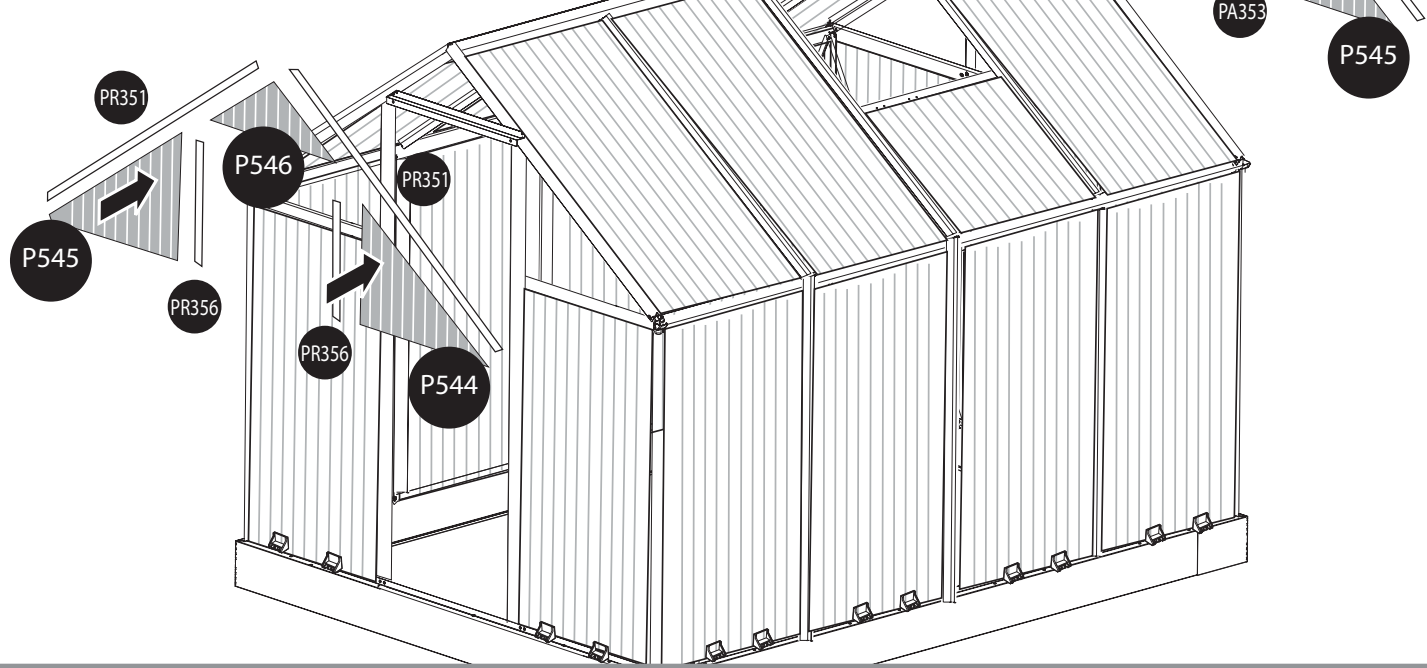
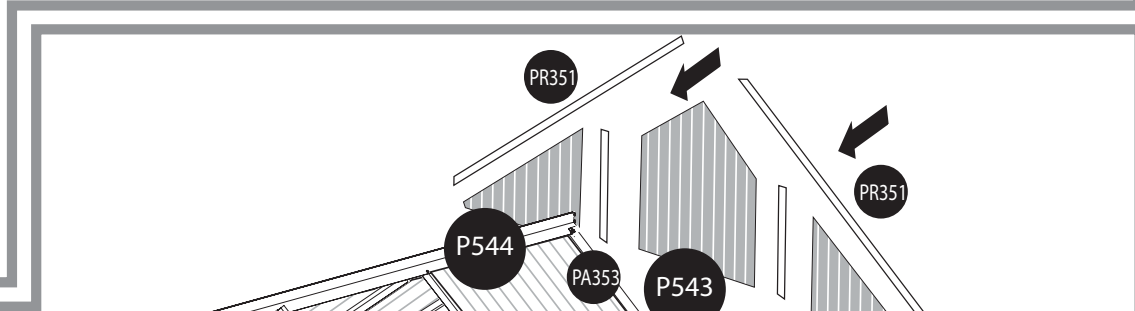
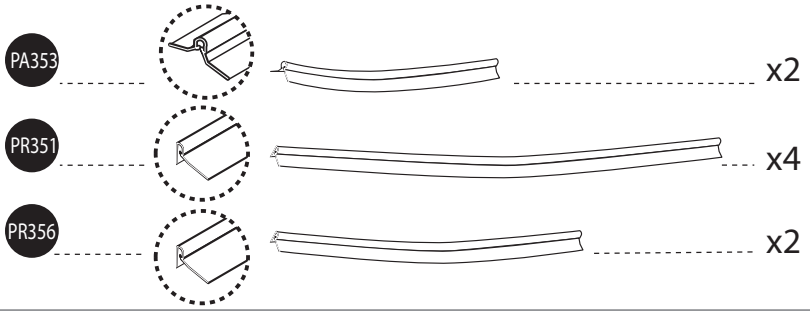
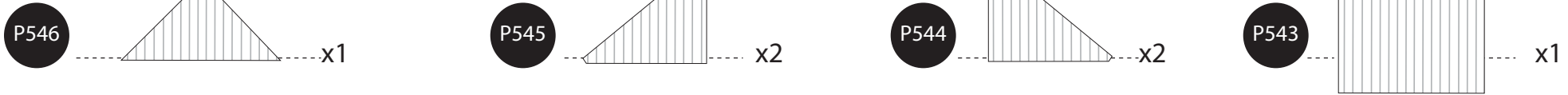
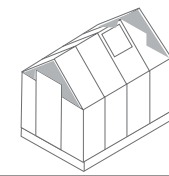

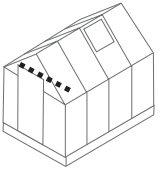

A222

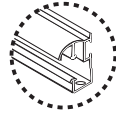
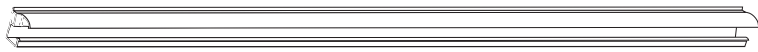

x1

411



x2

412



x2

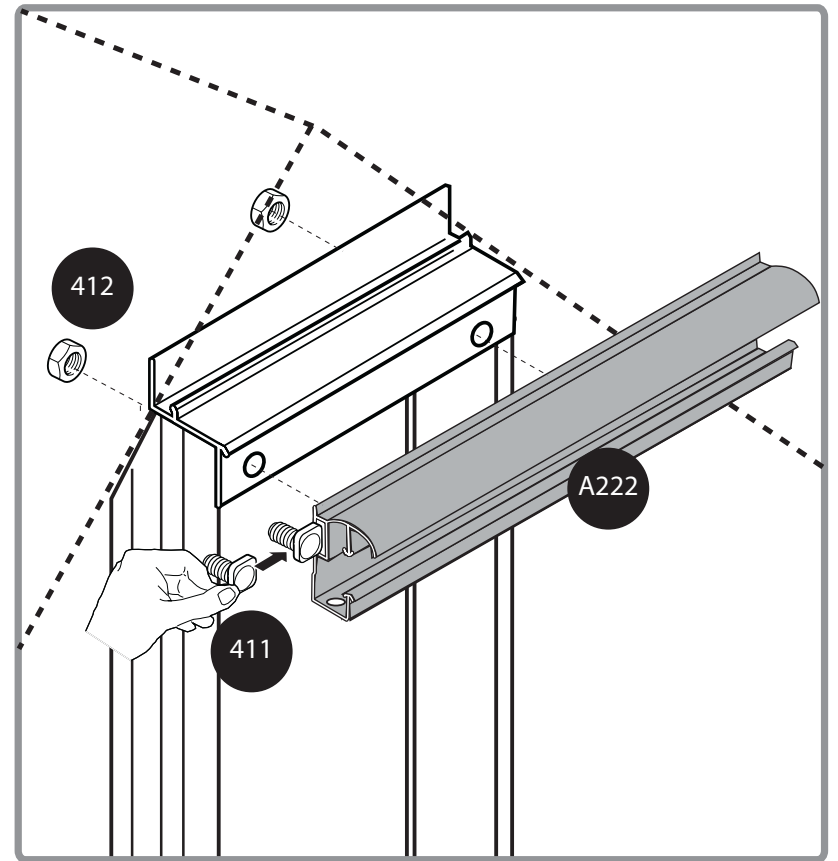
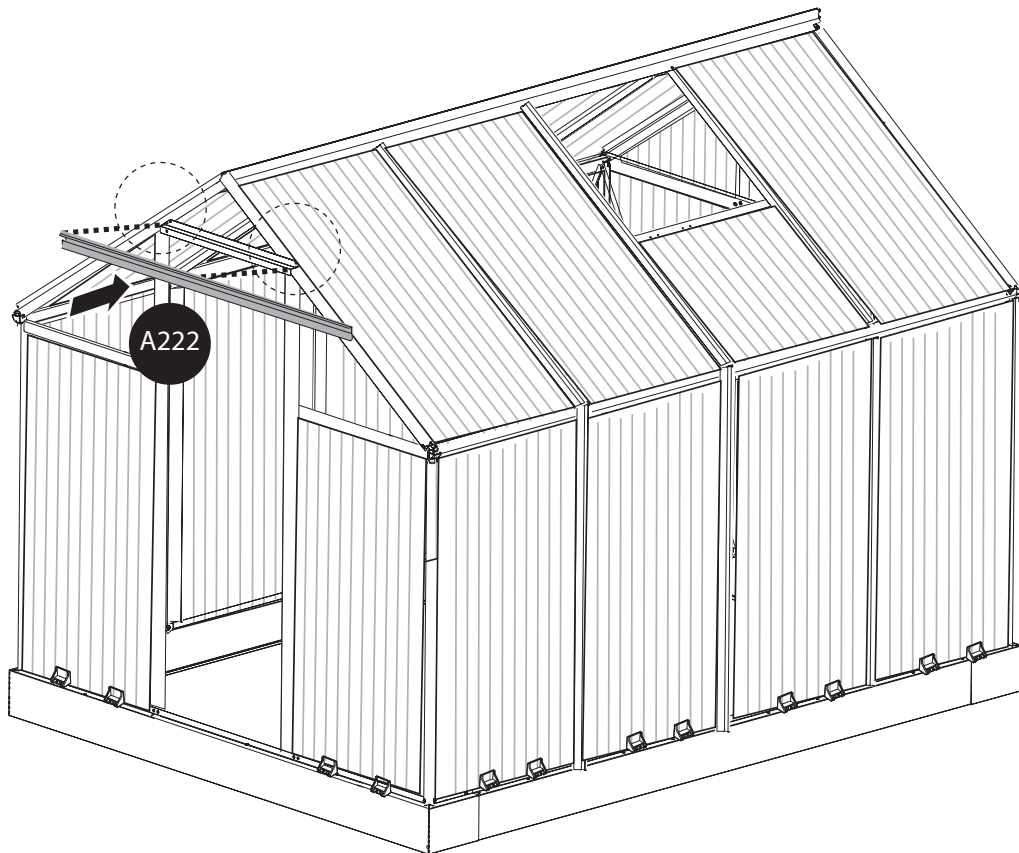

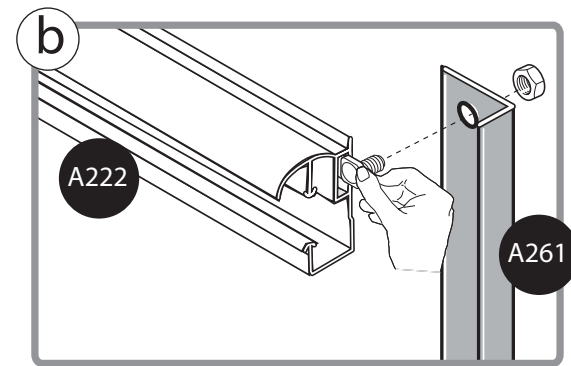
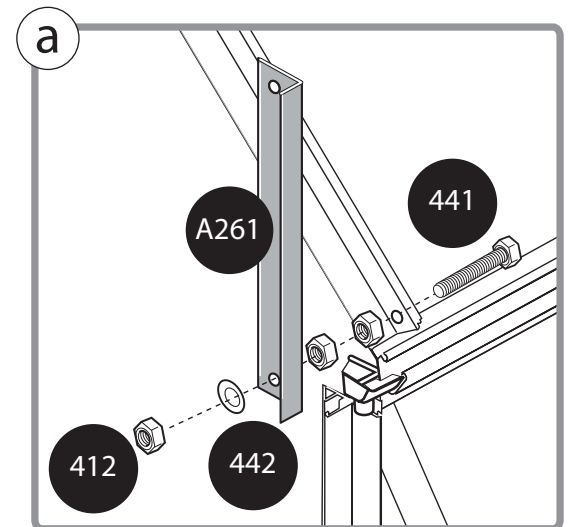
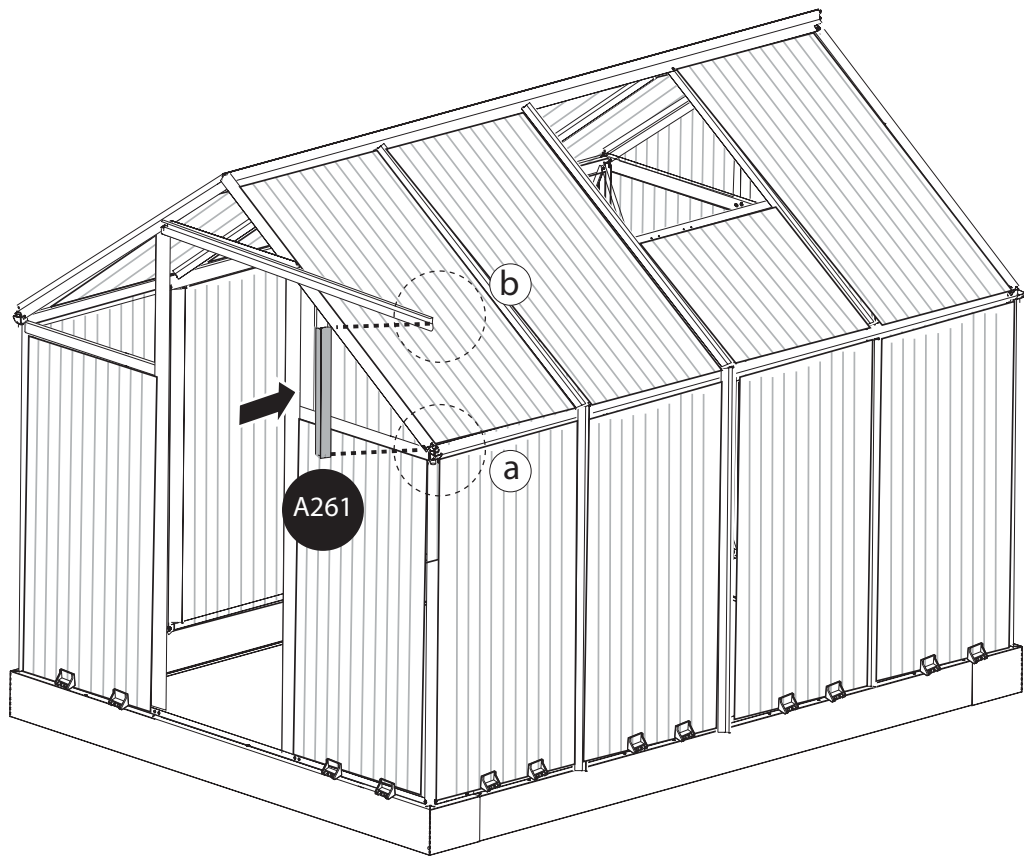
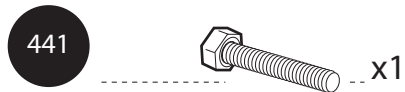
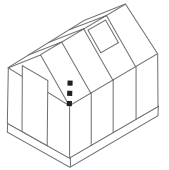

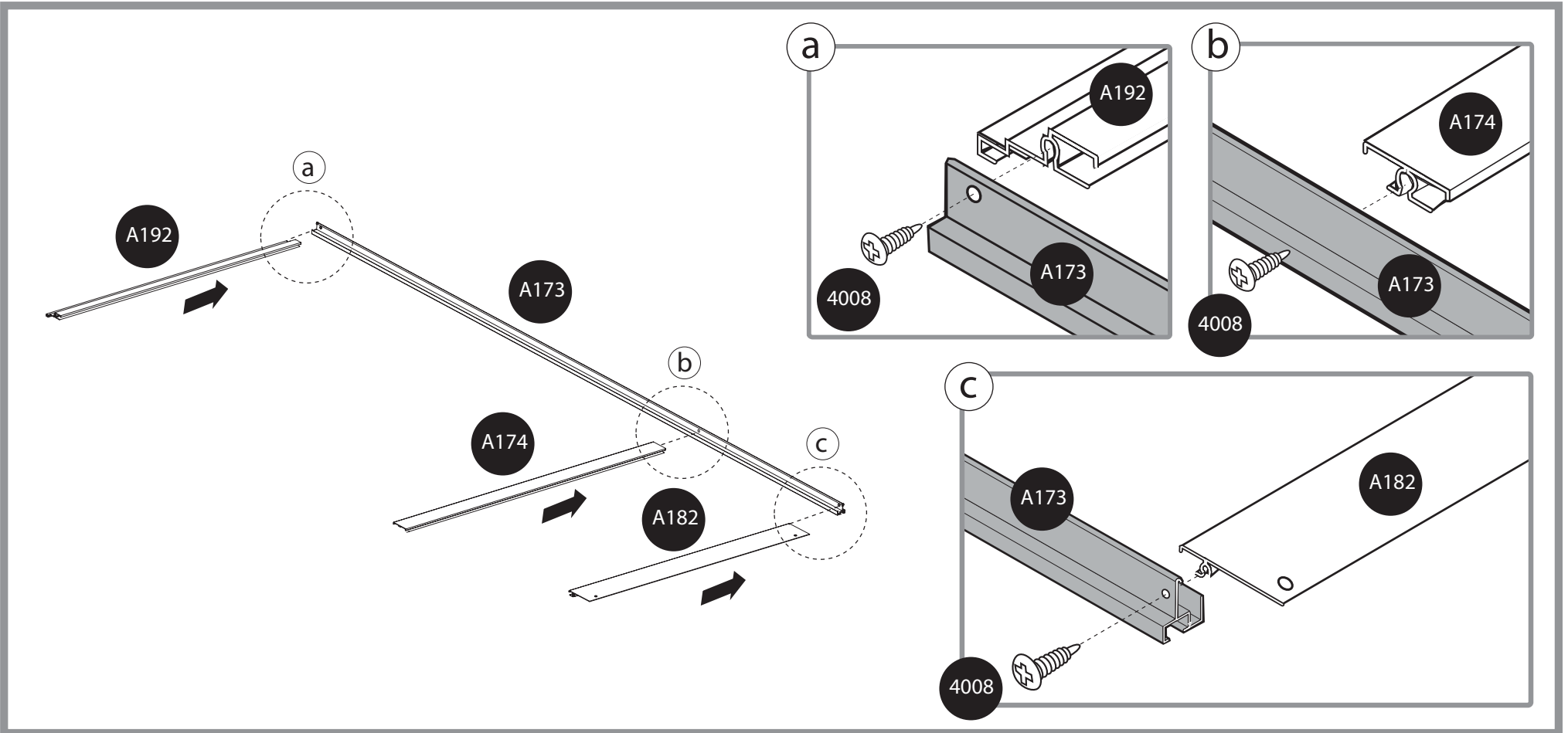
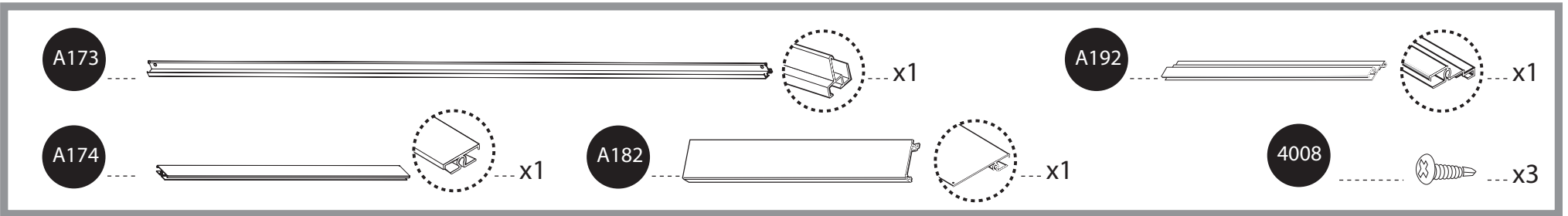
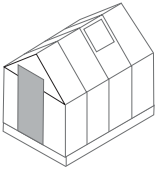

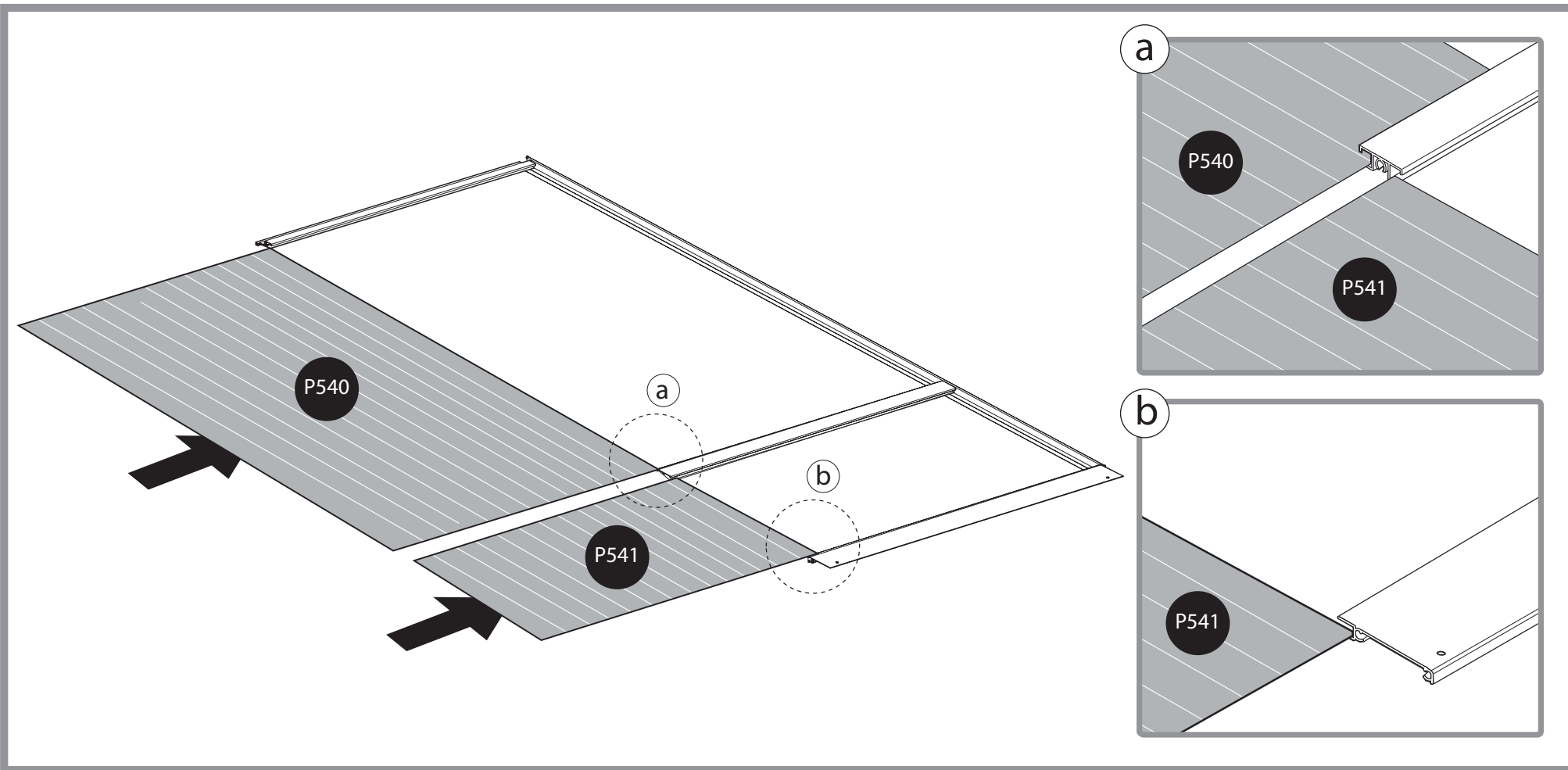
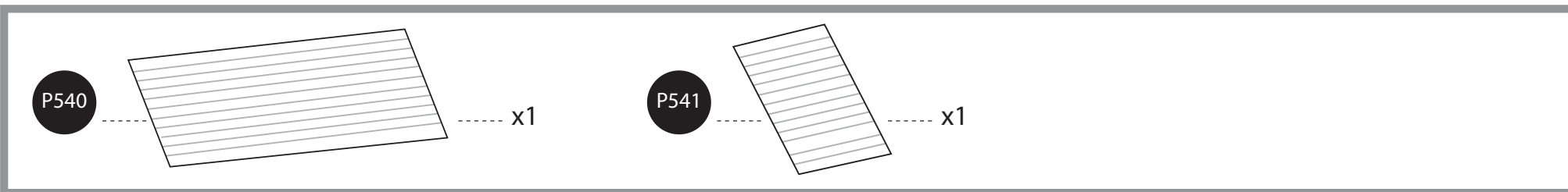
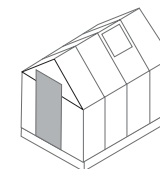

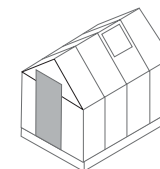

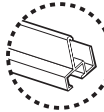



- A173   x1
- 4008  x3

- 423  x2
- 421  x2
- P304  x2

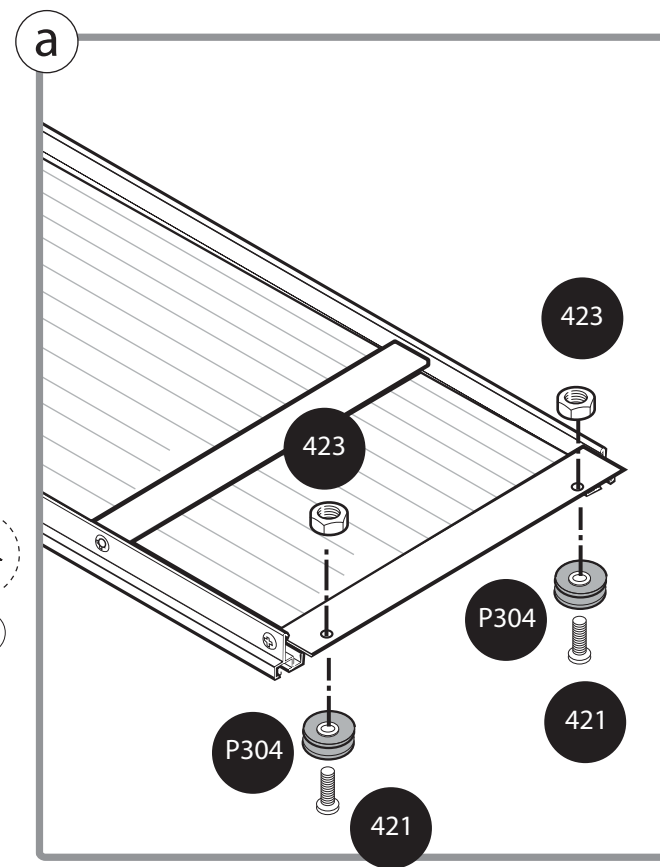
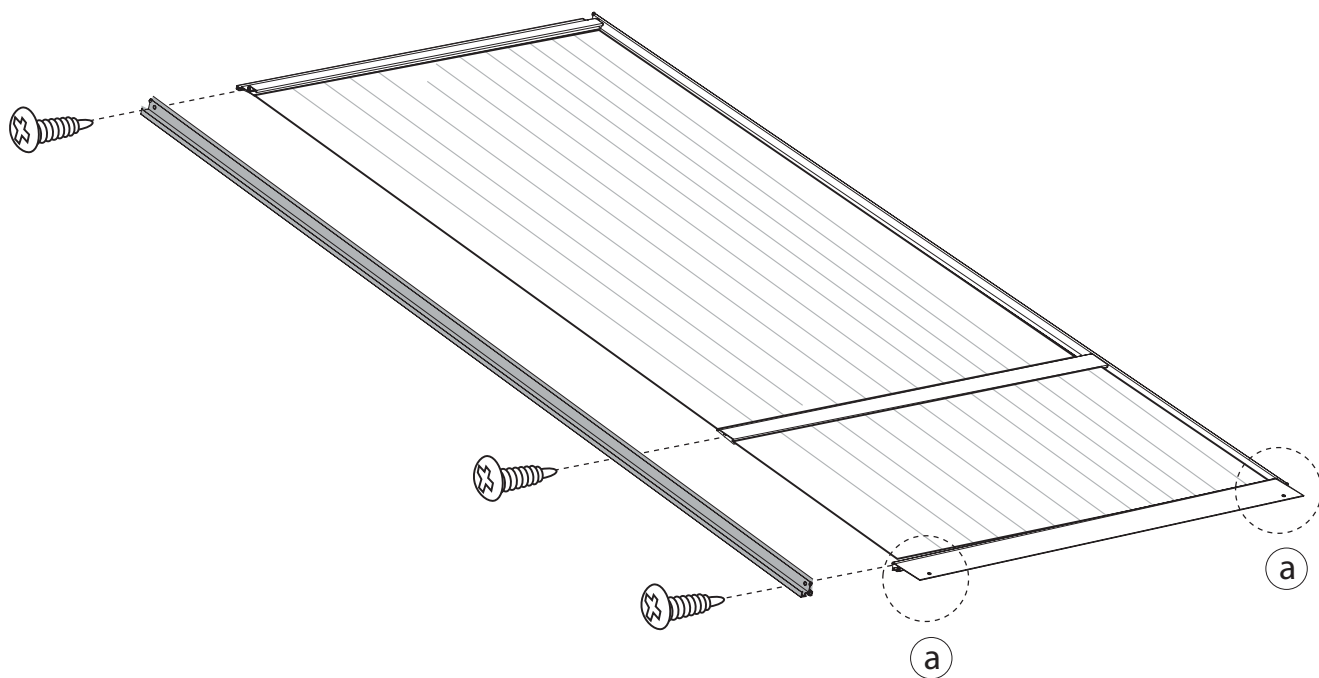

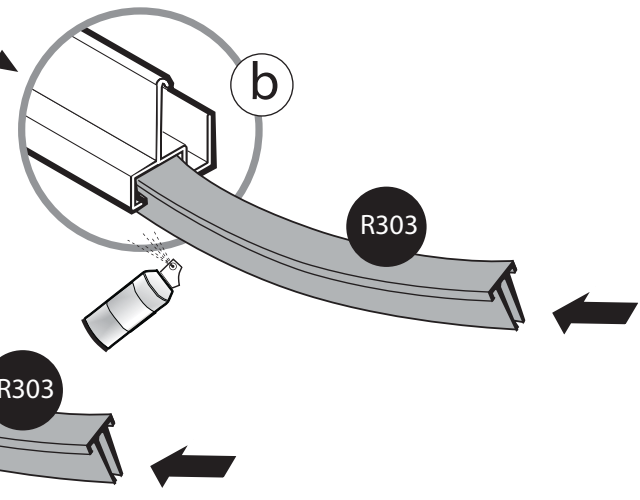
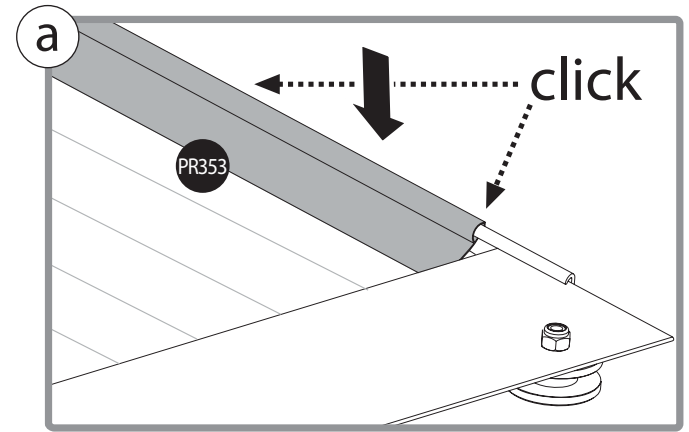
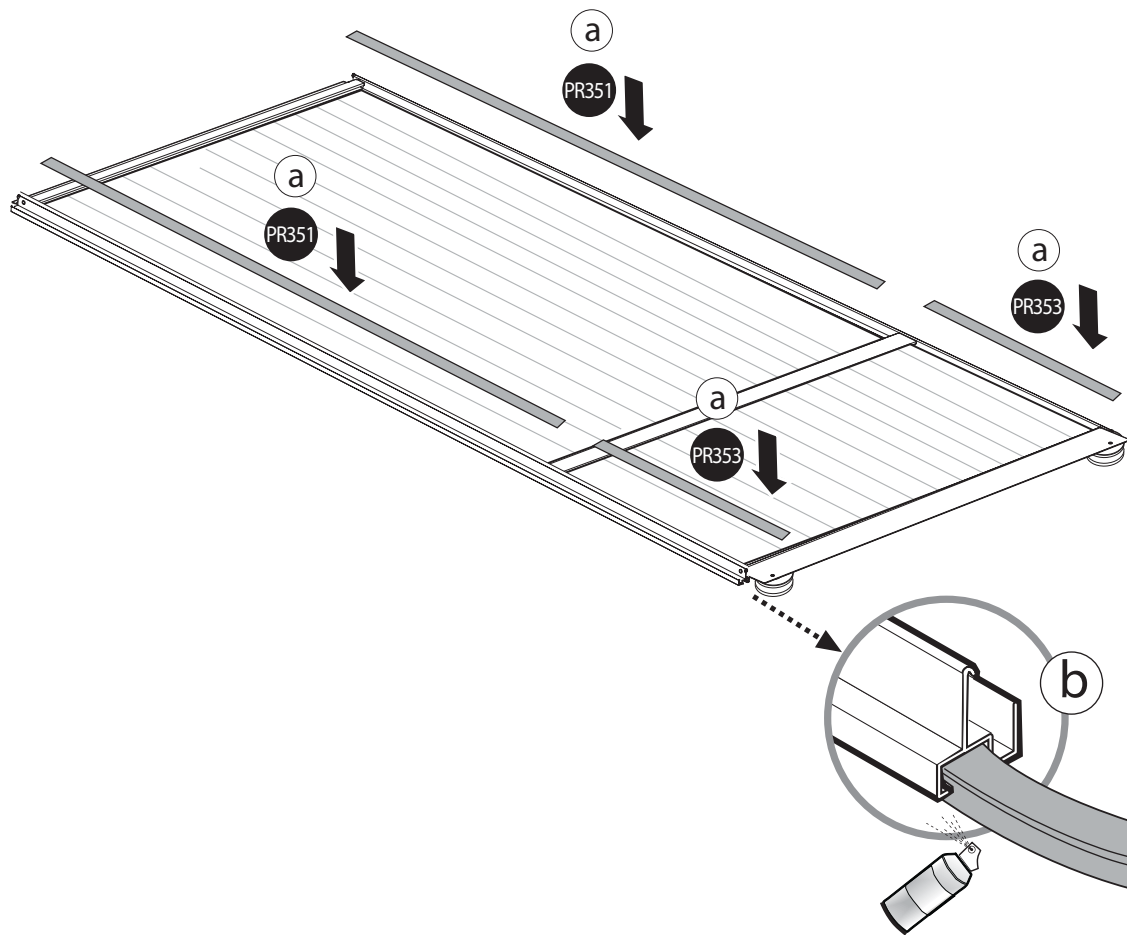
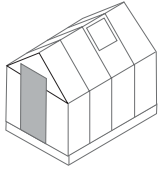

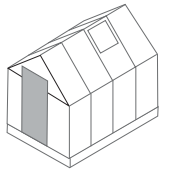

411



x1

412



x1

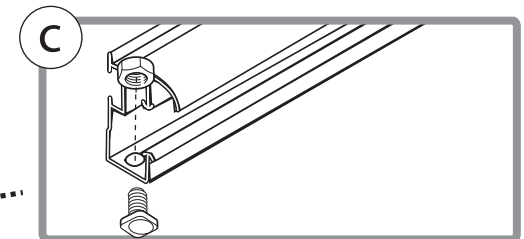
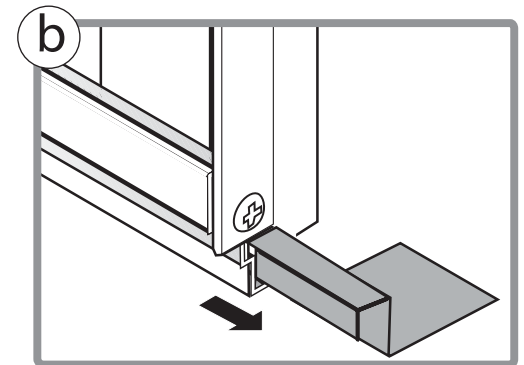
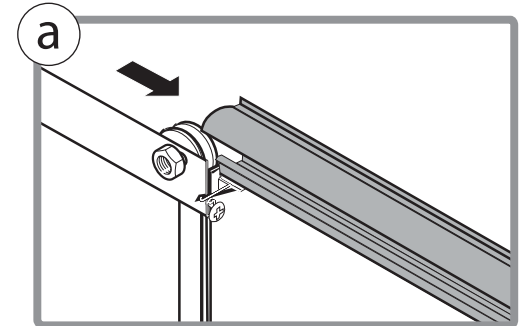
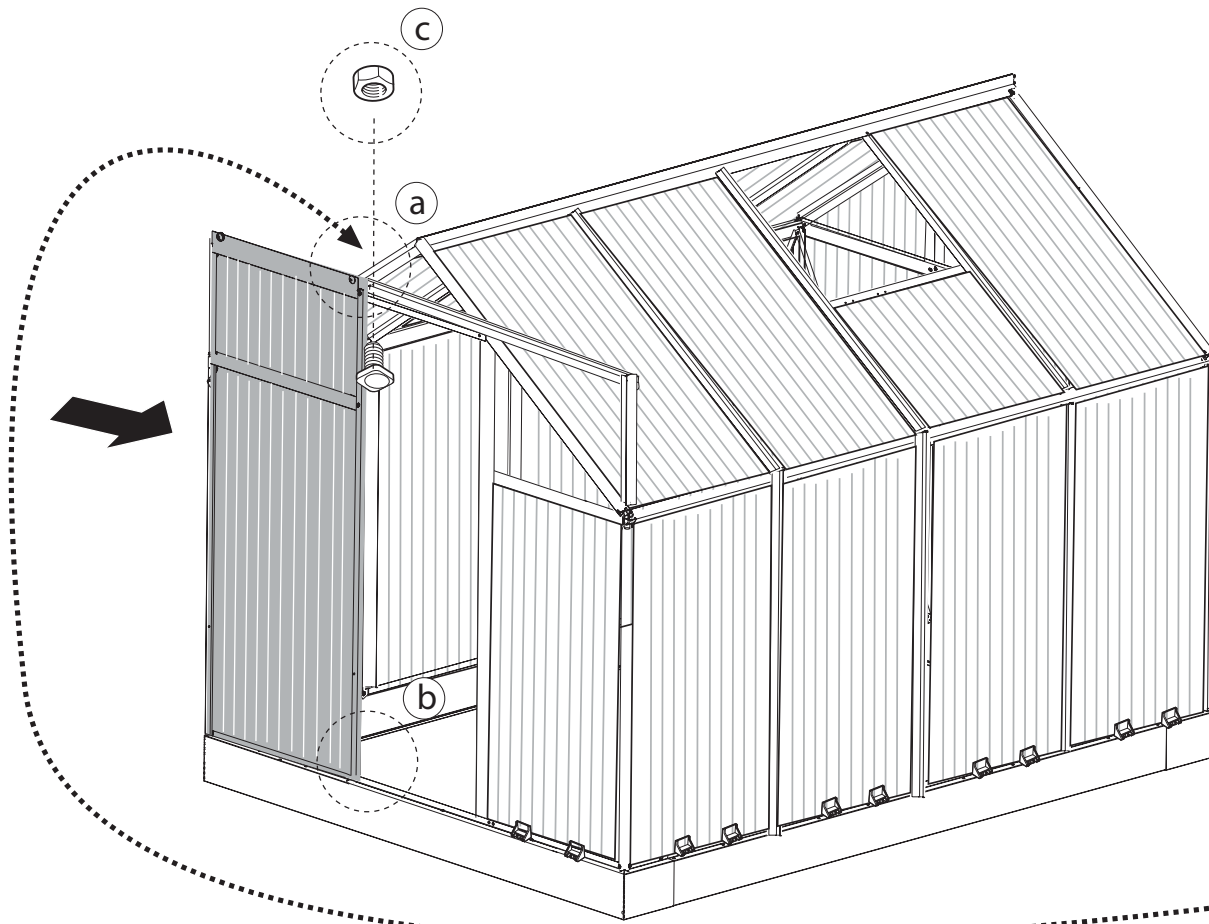

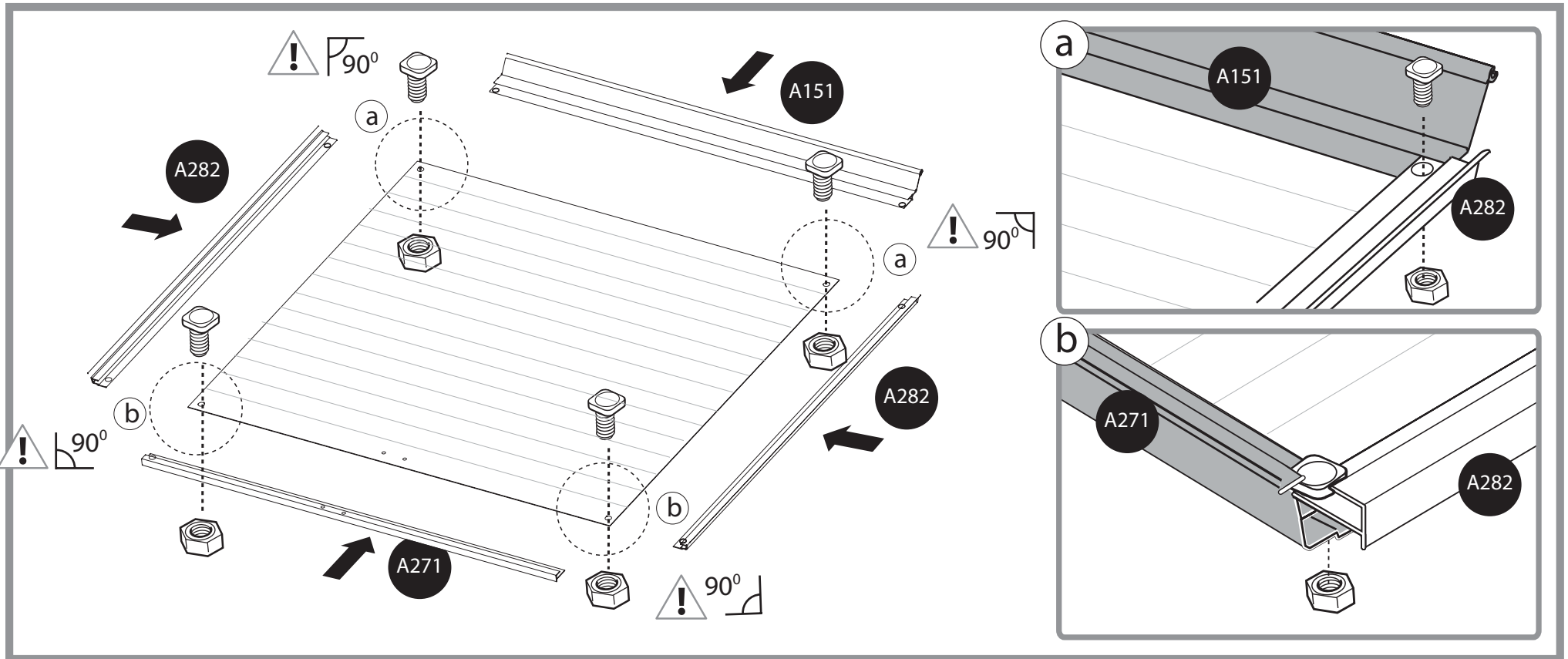
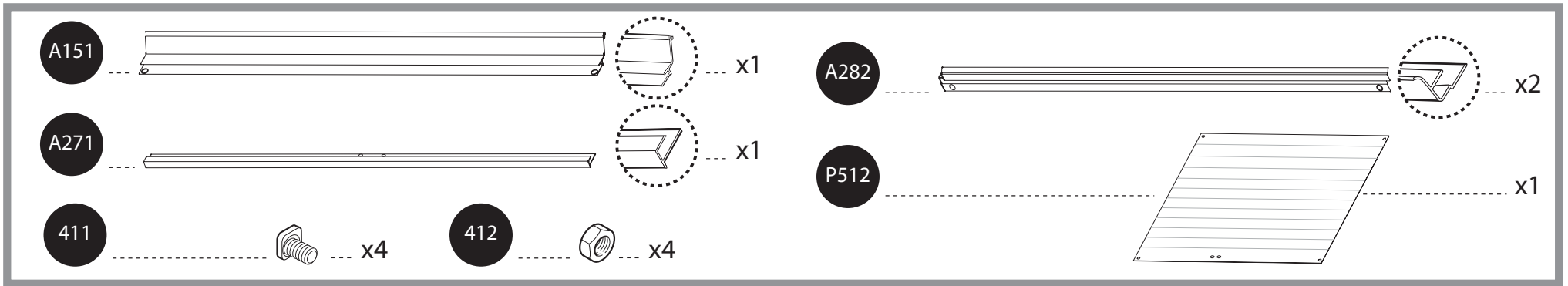
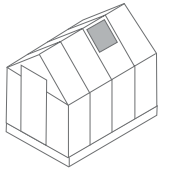

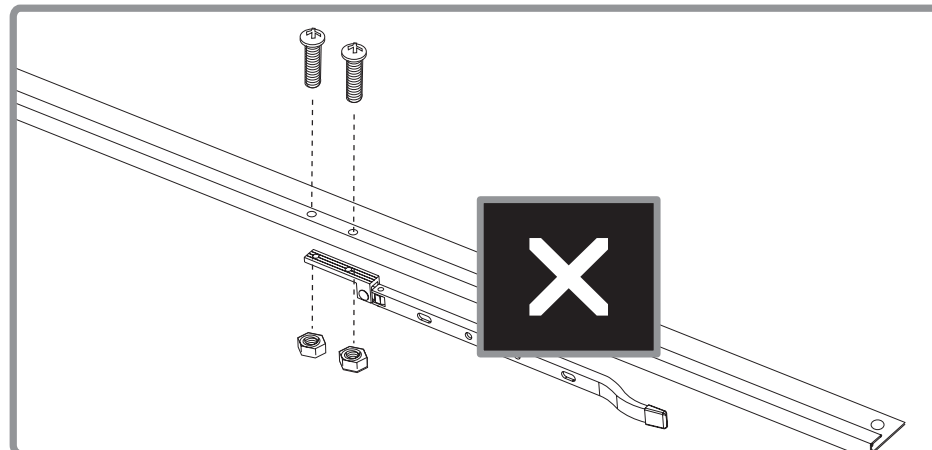
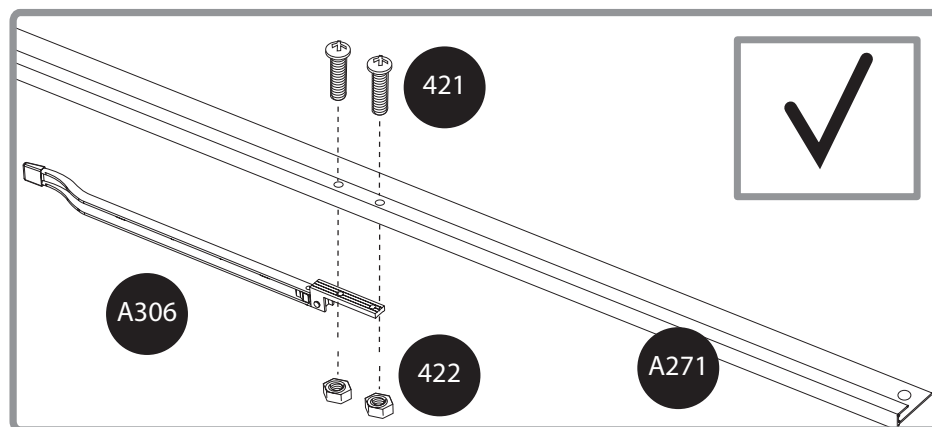
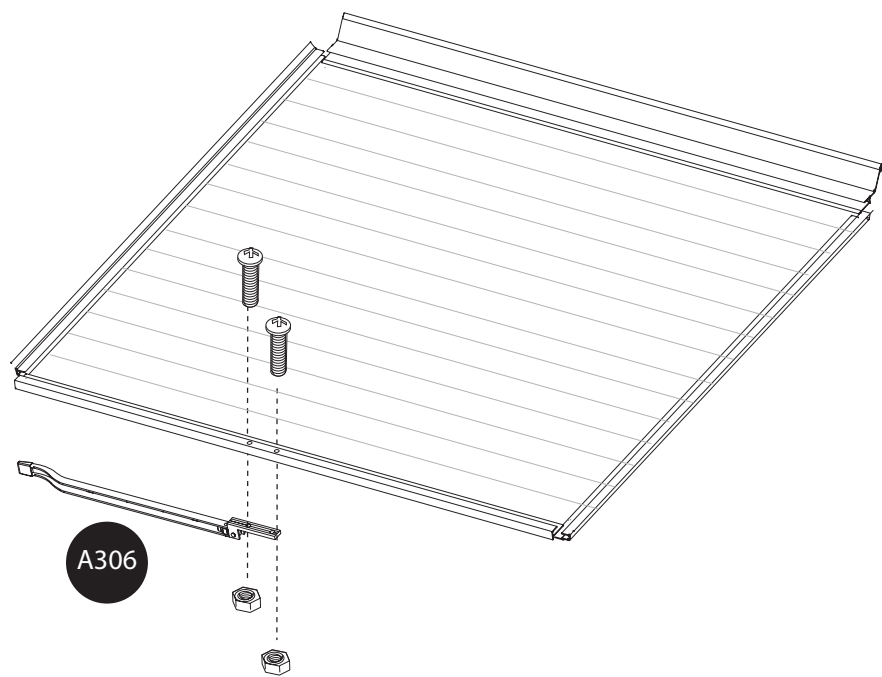
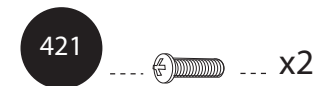
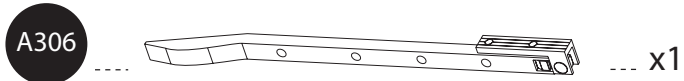
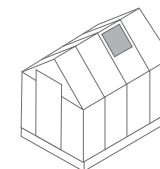

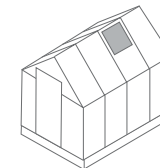

A323

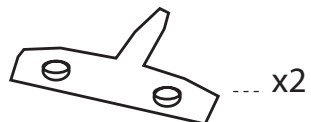

x2

445



x4

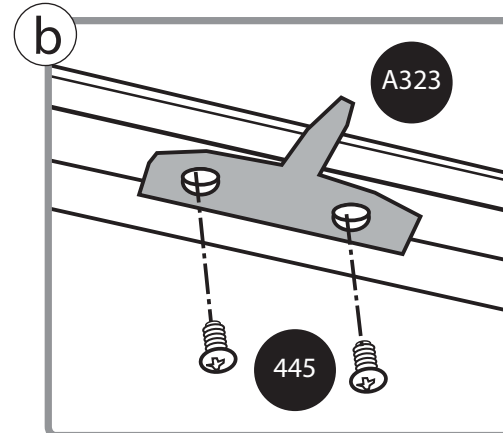
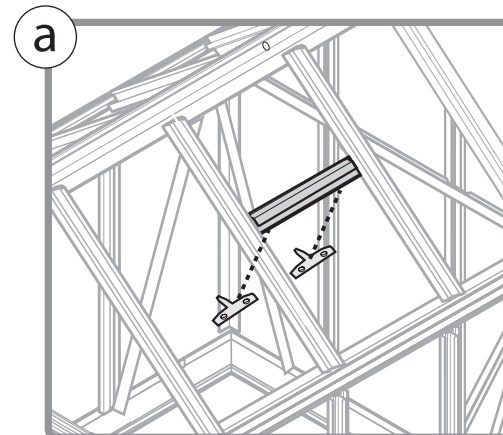
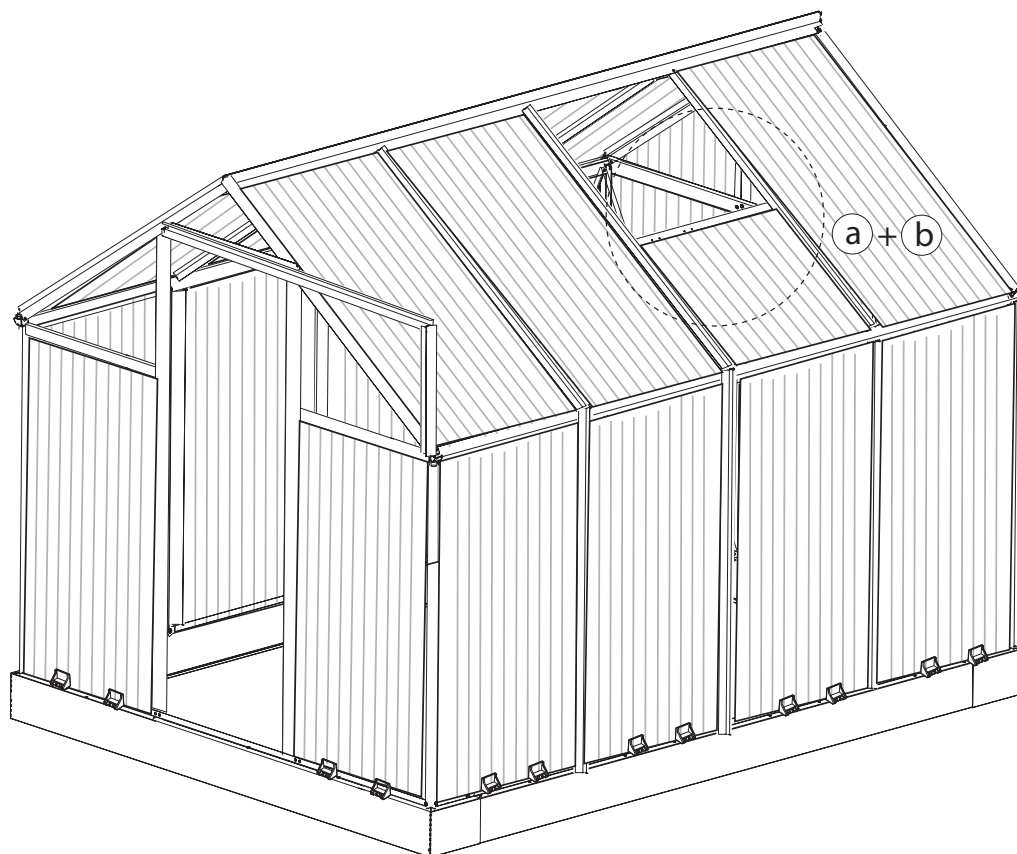

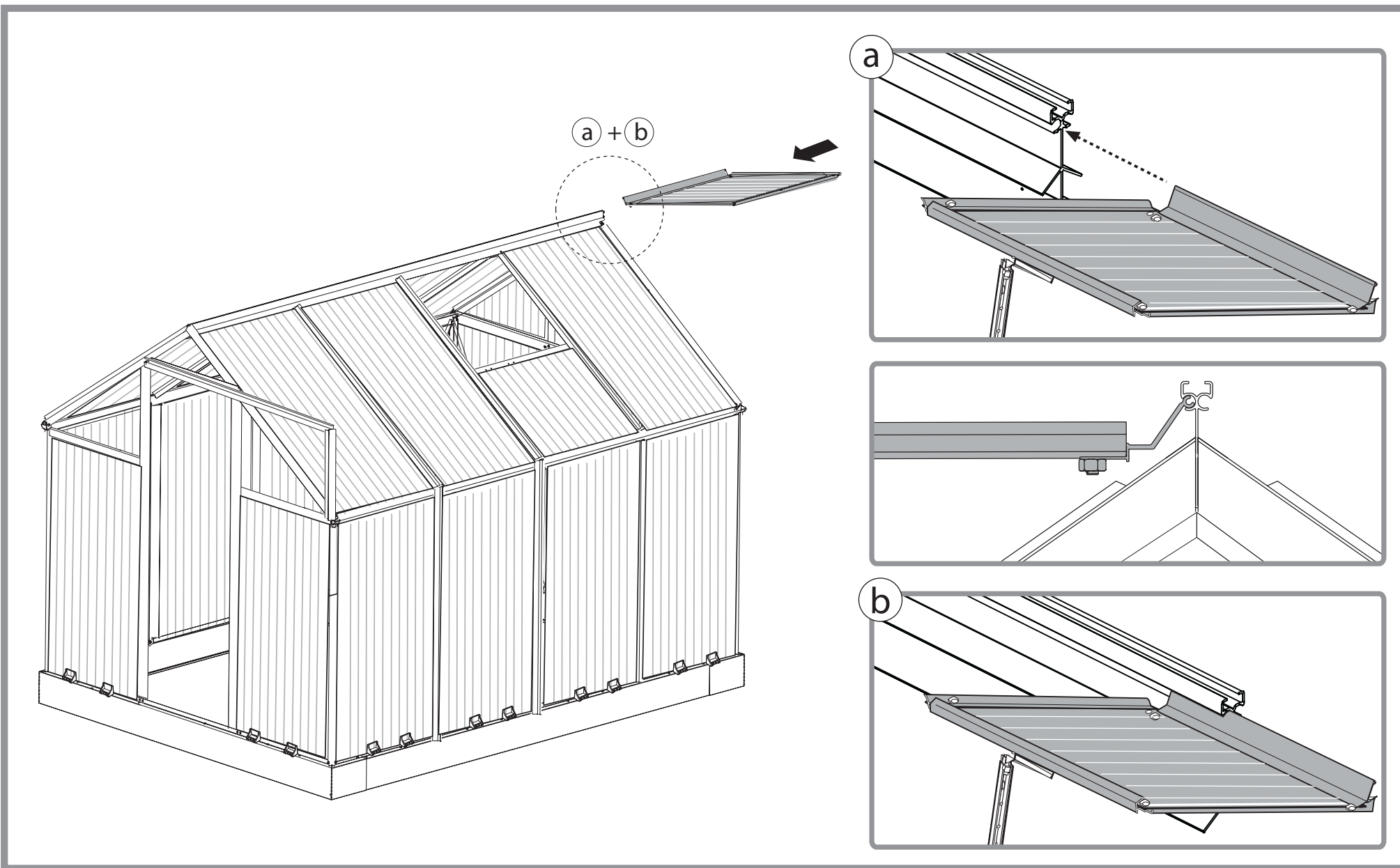
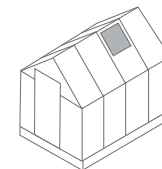

a + b

a

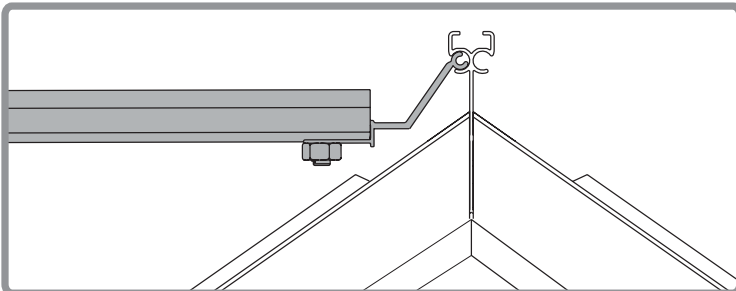
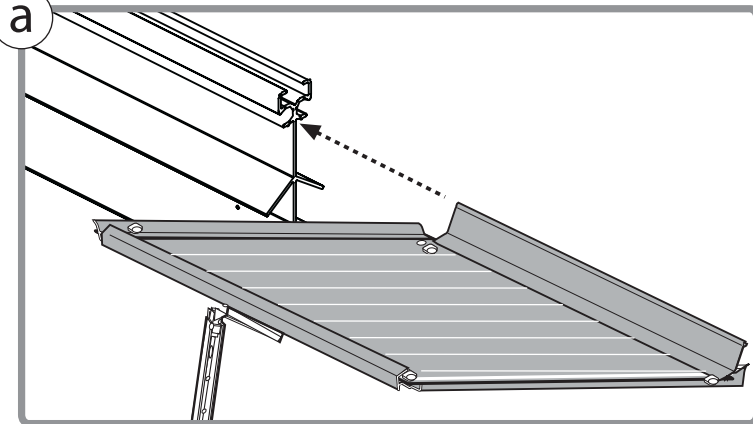

b

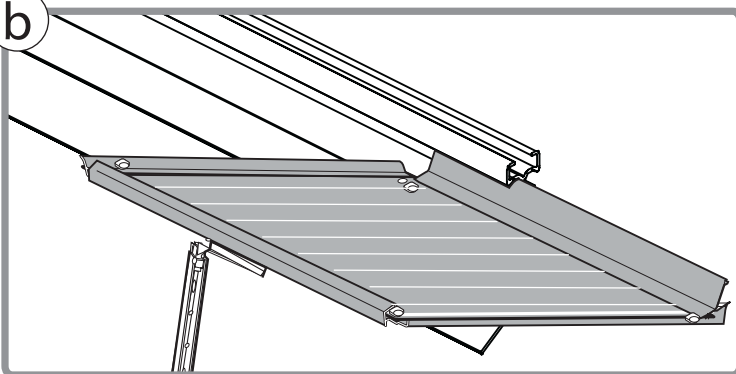

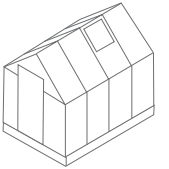

P399  x2

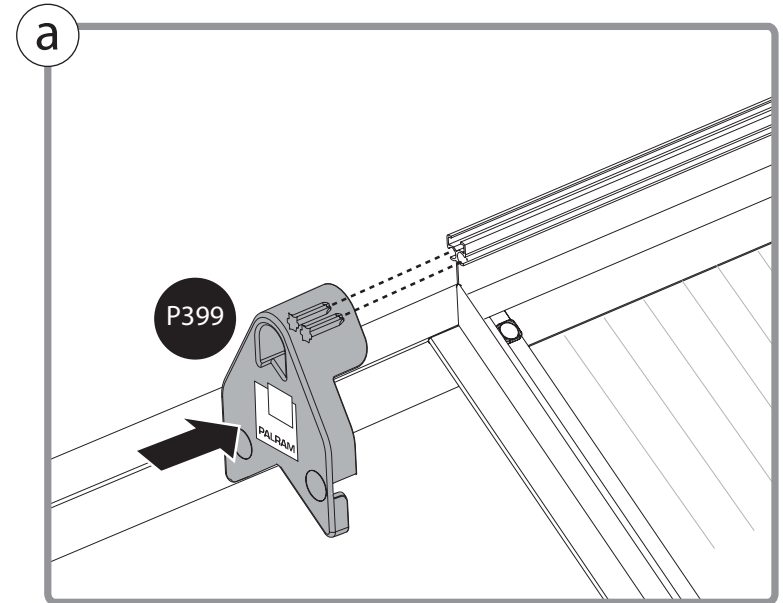
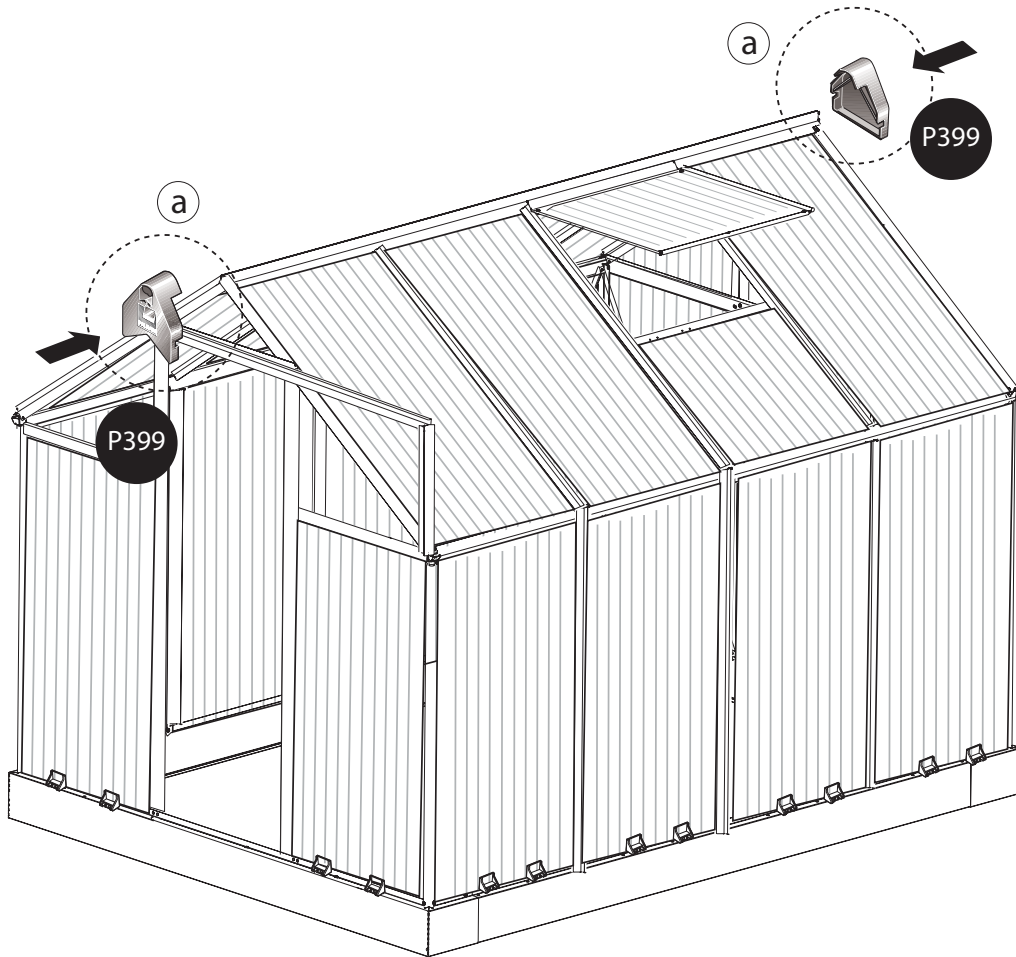

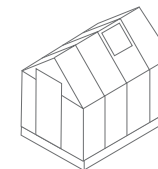

EN: Assemble parts T340 & T341 from the inside of the Greenhouse

FR: Assembler les pièces T340 et T341 de l'intérieur de la serre

G: Zusammenstellen von Teilen T340 und T341 aus dem Inneren des Greenhouse

SP: Ensamble las partes T340 y T341 en el interior del invernadero

IT: Assemblaggio di parti T340 e T341 dall'interno della serra

NL: Monteer delen T340 en T341 vanaf de binnenkant van de kas

SW: Montera delar T340 och T341 från insidan av växthuset

DA: Saml dele T340 og T341 fra indersiden af drivhuseffekten

FI: Kokoa osat T340 ja T341 sisäpuolelta Greenhouse

CZ: Sestavte díly T340 & T341 z vnitřní skleník

SL: Zberite deli T340 in T341 iz notranjosti toplogrednih

POL: Złożyć T340 i T341 części od wewnątrz szklarni

RO: T340 și T341 Asamblarea piese din interiorul cu efect de sera

NO: Sett sammen deler T340 og T341 fra insiden av Greenhouse

POR: T340 e T341 Montar peças do interior da estufa

SK: Zostavte diely T340 & T341 z vnútornej skleník

T340  x7

T341  x8

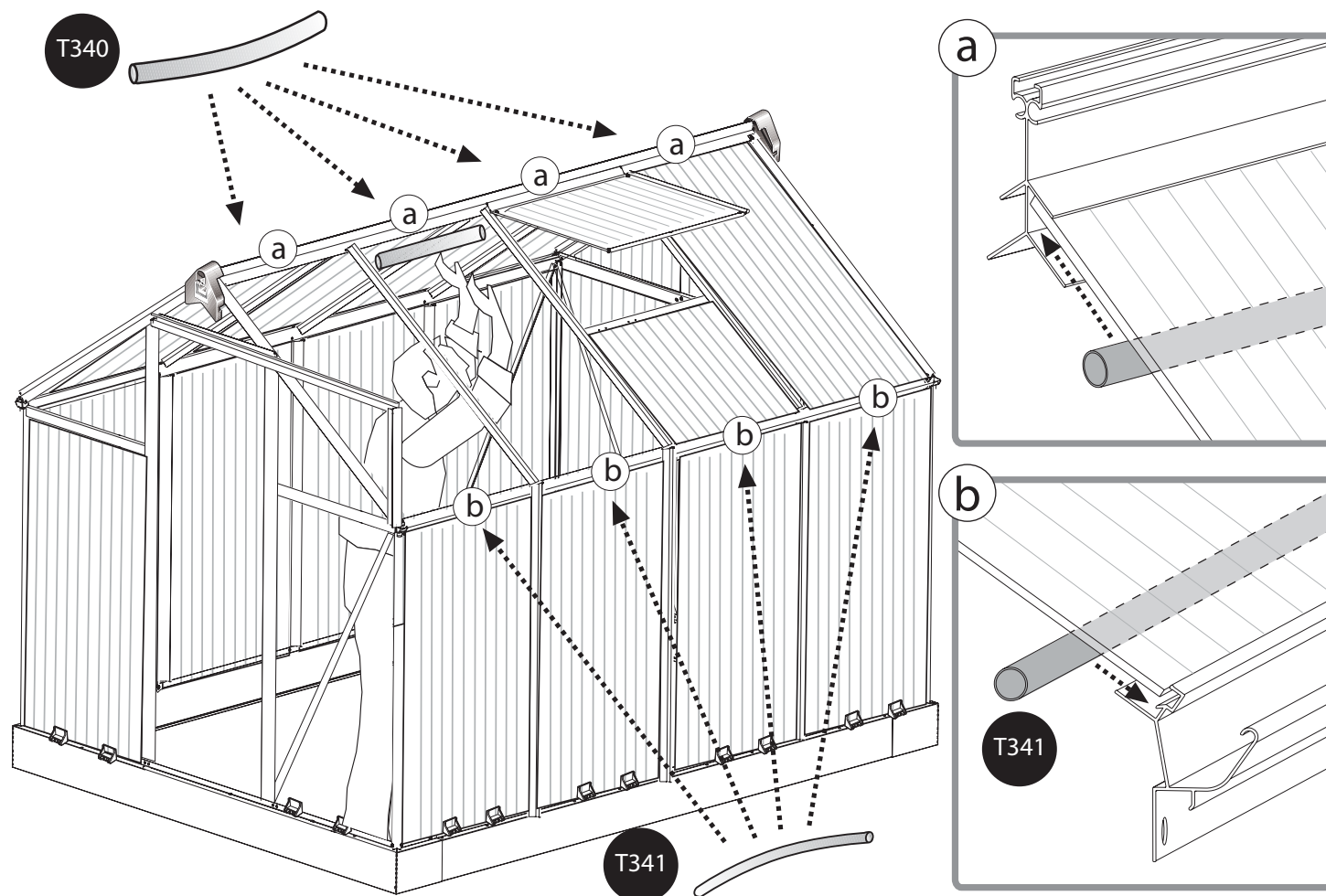

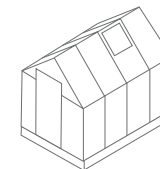

p361

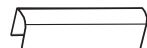

x113

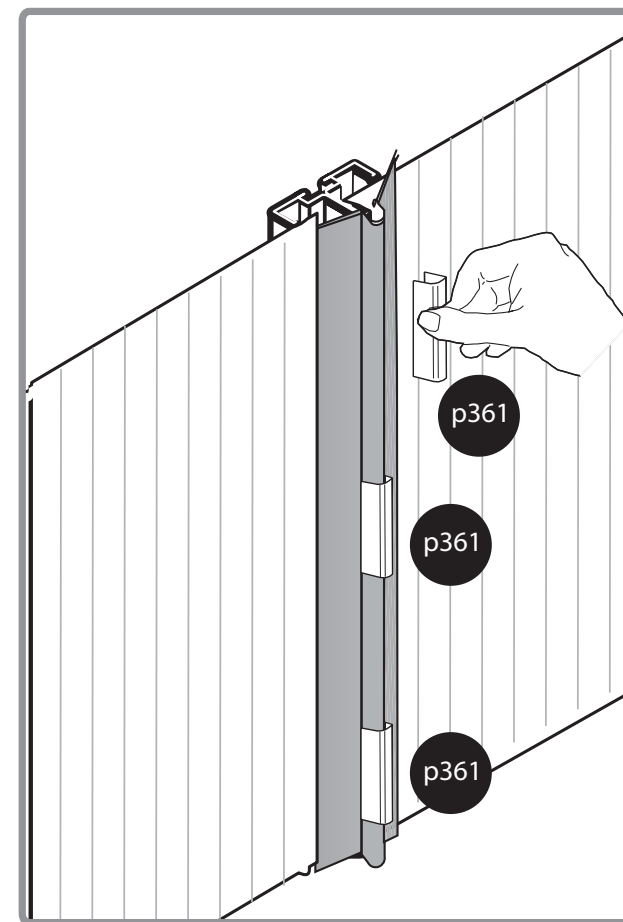
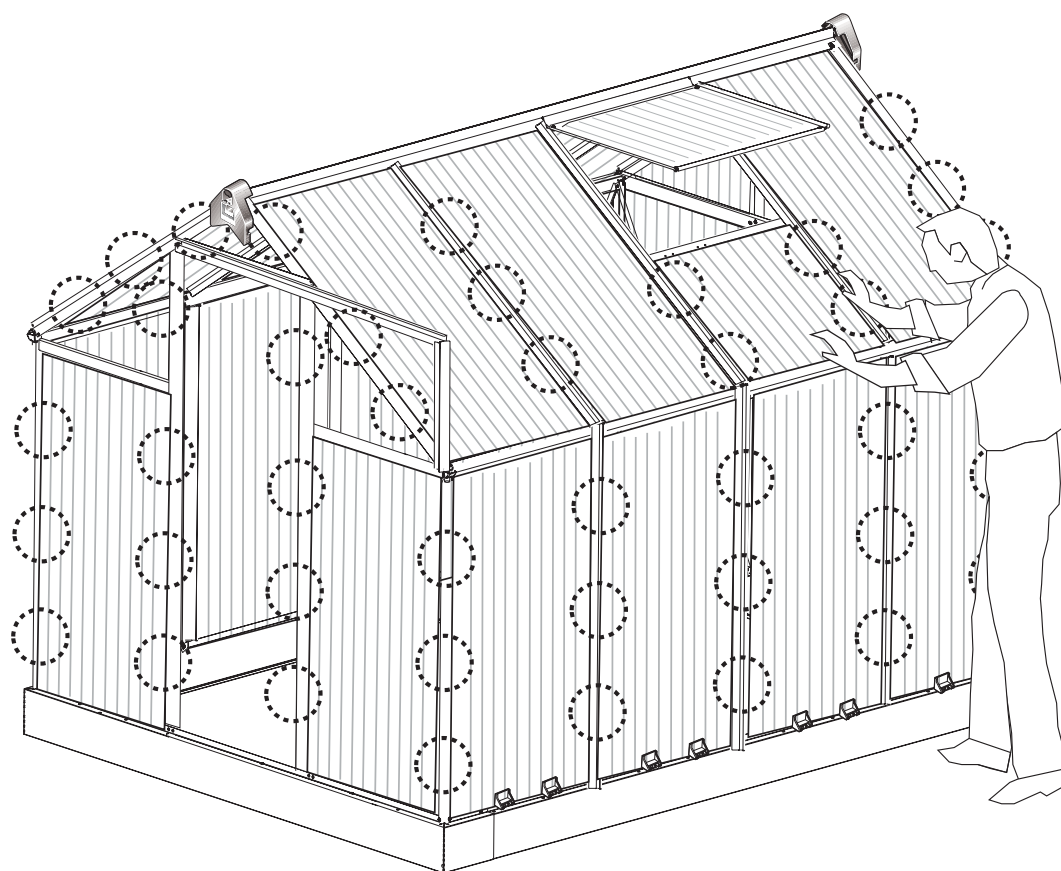

43

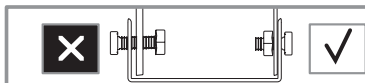

412



411

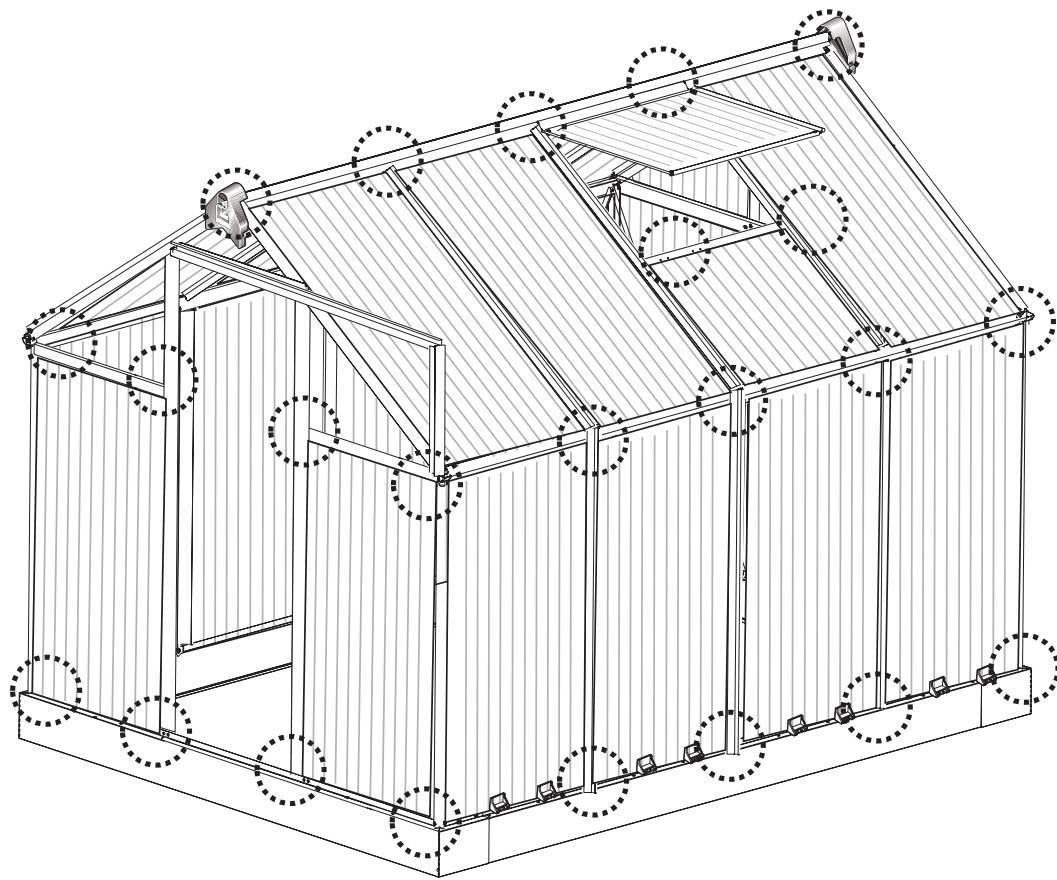
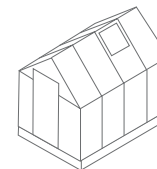

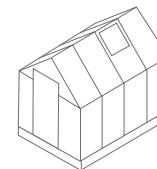

M307

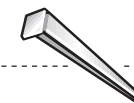

x4

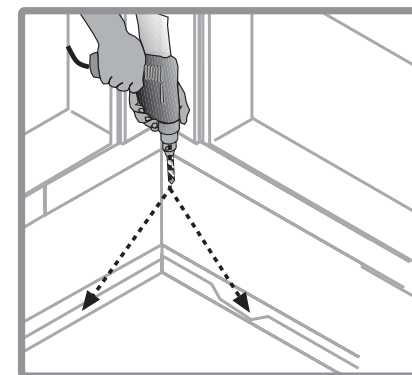
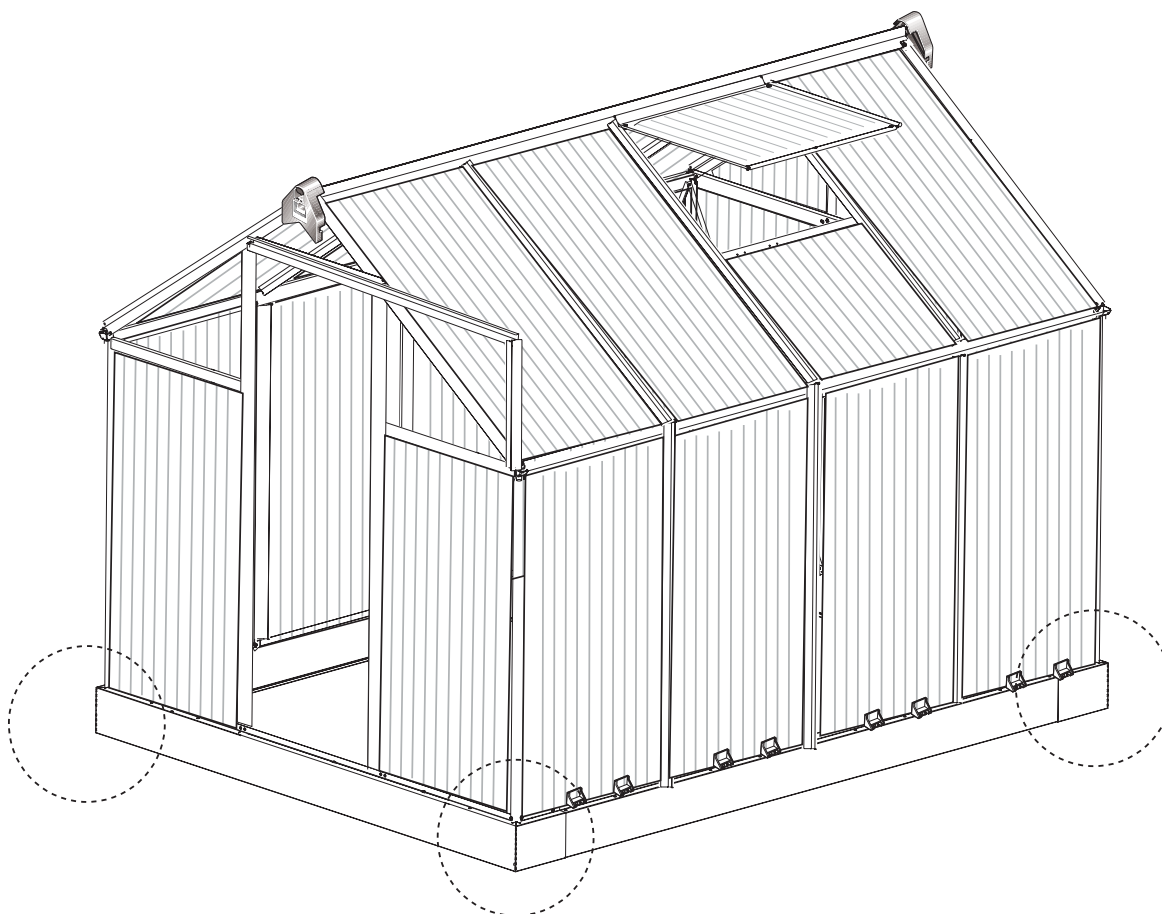

or

