

HAVA CABANA shade systems

ASSEMBLY INSTRUCTIONS

NOT FOR CONSTRUCTION.
Refer to manual provided with
materials used for installation



P.O. Box 458
27725 Danville Avenue
Castle Rock, MN 55010
www.poly-tex.com

REV: AB-130308

U.S. & Canada Toll
Free
800-852-3443
(651) 463-7009
fax (651) 463-2479

POLY-TEX
Greenhouse & Display Systems

SAFETY GUIDELINES

PLEASE READ THE INSTALLATION INSTRUCTIONS CAREFULLY BEFORE BEGINNING TO ASSEMBLE THE STRUCTURE. SAVE THESE INSTRUCTIONS FOR FUTURE REFERENCE.

WARNING

This structure is intended to be self-supporting once constructed with all frames, hardware, sheathing, sheeting, bracing, cables, and membrane in place and secured to the foundation as shown in the manual. Stability during construction, from winds and loads imposed during erection, is the sole responsibility of the installer. Observe safety codes required by your jurisdiction, and relevant safety practices for working at heights. Avoid the risk of electrical shock from overhead lines or electrical storms. Poly-Tex recommends contracting a licensed electrician to perform electrical work. Eye protection is recommended under all circumstances and hearing protection is recommended when cutting components with power tools.

Foundations

These instructions include minimum guidance for foundations based on the International Building Code. These minimums are suitable for some areas of the country but not all. Obtain a building permit if required in your jurisdiction. Engineered Certified foundation plans may be required by a building official before issuing a permit. Even if not required, seeking guidance from a qualified structural or civil engineer for the foundation design may improve the life of the structure.

DANGER

No part of this structure is engineered to function as an anchorage point for a fall arrest system. Use a safety net or work from a safe work platform (i.e. scaffolding). Select a calm day for work. Wind can be sufficient enough to knock materials or workers off a work platform or ladder, resulting in a potentially deadly fall.

Overview of assembly procedure

While each structure and site is unique, and may require special considerations, these instructions are for a tilt-up method (where frames are assembled on the ground and tilted onto ground stakes or anchor rods using ropes or lifts). If installer is not confident to erect the structure, Poly-Tex suggests you hire a general contractor, carpenter, or similar licensed business familiar with construction to assemble and erect the structure.

DANGER

Do not overload structure. Consult with a Poly-Tex representative prior to adding any amount of weight over the specified capacity of this structure. Basket purlins, shelving or any objects of significant weight shall not be hung, attached, or secured to roof or truss members in a manner that will overload the structure.

WARNING

Do not walk on polycarbonate sheets. If the structure is to be covered with polycarbonate sheets, always use scaffolding for the erection process to avoid damage to sheeting and to ensure safety. Polycarbonate sheeting has UV coating protected with vinyl film on the exterior surface. Install sheets with the film intact and toward the exterior. Remove film once the sheet has been fastened in place.

HAVE CABANA

Index

PART IDENTIFICATION	Pg 1
LAYOUT & ANCHORING	Pg 2
FRAME ASSEMBLY	Pg 3
DIAGONAL STRUTS & PURLINS	Pg 4
GABLE END FRAMING	Pg 5
TOP COVER, ROLL-UP SIDES, & ENDS	Pg 6

PARTS IDENTIFICATION

HAVA CABANA

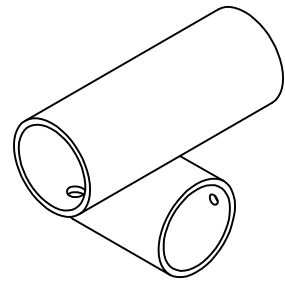

HC PEAK CONNECTOR
(HC6005)

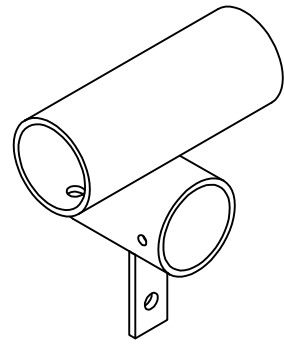

21' PEAK CONNECTOR
W/TAB (SNAP) (HC6006)

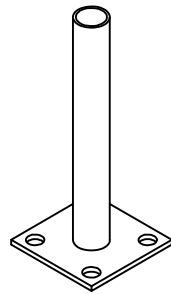

LEG STAND
(PT2433)



11'-3" STRT HOOP SECTION
HC W/ PLATE (HC6012)

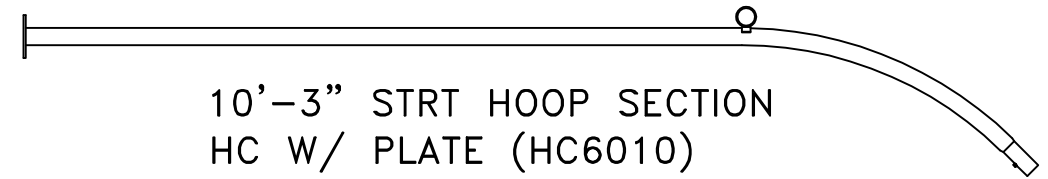

10'-3" STRT HOOP SECTION
HC W/ PLATE (HC6010)

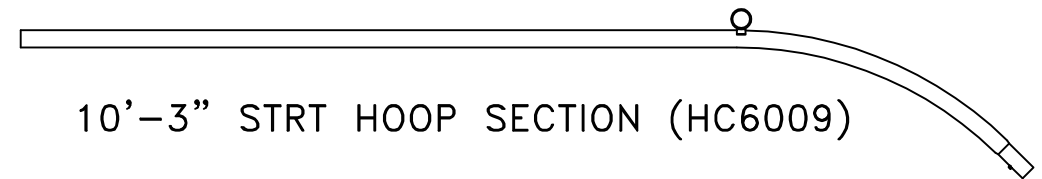

10'-3" STRT HOOP SECTION (HC6009)

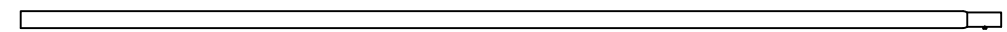

END WALL VERTICAL (HC 6103)

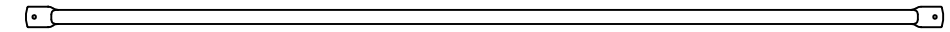

DIAGONAL STRUT (HP3315)

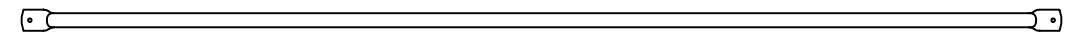

10' x 1.66" END FRAME TRUSS (HP3337)
(OPTIONAL)

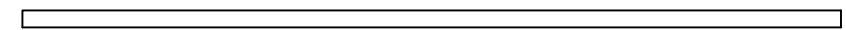

2" x 96" PURLIN (HC1002)

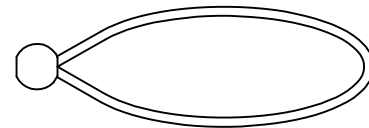

BUNGEE BALL
(PT2521)

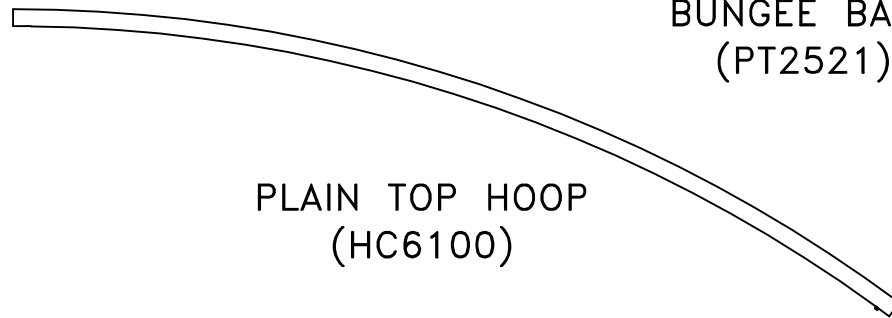

PLAIN TOP HOOP
(HC6100)

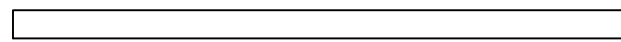

GROUND STAKE
(GS2400)

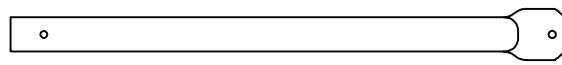

END WALL EXTENSION
(HC6104)

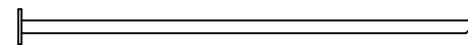

18" SPIKE
(BMS1130)

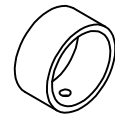

\"/>

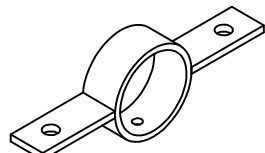

\"/>

IMPORTANT NOTE:

ALL COMPONENTS ATTACHED TO LONG SPEED HOOKS MUST BE MOUNTED ON THE OUTSIDE OF THE TABS. NEVER INSTALL COMPONENTS BETWEEN TABS.

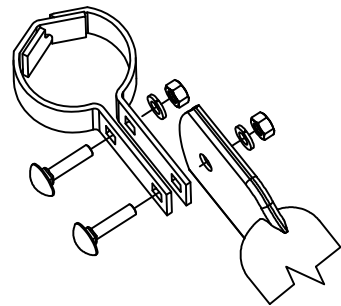

(2) LONG SPEED HOOKS
(FT2079)

LAYOUT AND ANCHORING

NOTE: AS ACCURACY IN THIS PART OF THE WORK IS VERY CRITICAL, PLEASE MAKE SURE THAT THIS PAGE IS THOROUGHLY UNDERSTOOD BEFORE PROCEEDING.

To square up the structure, measure diagonally. These measurements should be the same. Once this is complete, check all four sides of the layout to see that they are correct. If the structure is larger than 96', you may want to divide it into two or more sections (See Drawing A).

There are three options for anchoring the structure. Follow instructions for the option that applies to yours (see Drawings B, C & D).

The "A" fitting slides over the ground stake and will determine the height of the frames. All "A" fittings should be level. To determine "A" fitting height, use a string or chalkline from the first ground stake to the last.

Your "A" fittings may now be set using 5/16" X 3/4" hex head bolts. Install fittings so the heads of the bolts face the inside of the structure (See Drawing E).

NOTE: FOR MAXIMUM STABILITY, IT IS IMPORTANT THAT YOU SET THE "A" FITTINGS AS LOW AS POSSIBLE.

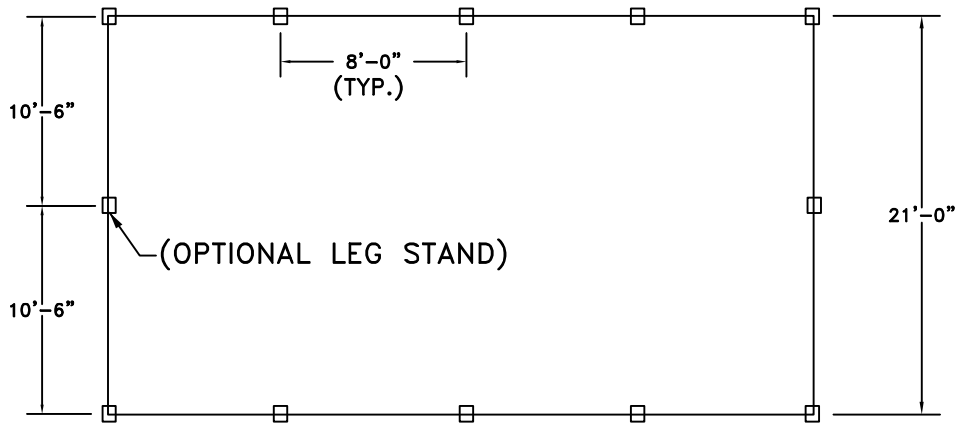

NOTE: ALL MEASUREMENTS CENTER-TO-CENTER OF GROUND STAKES OR BASE PLATE.

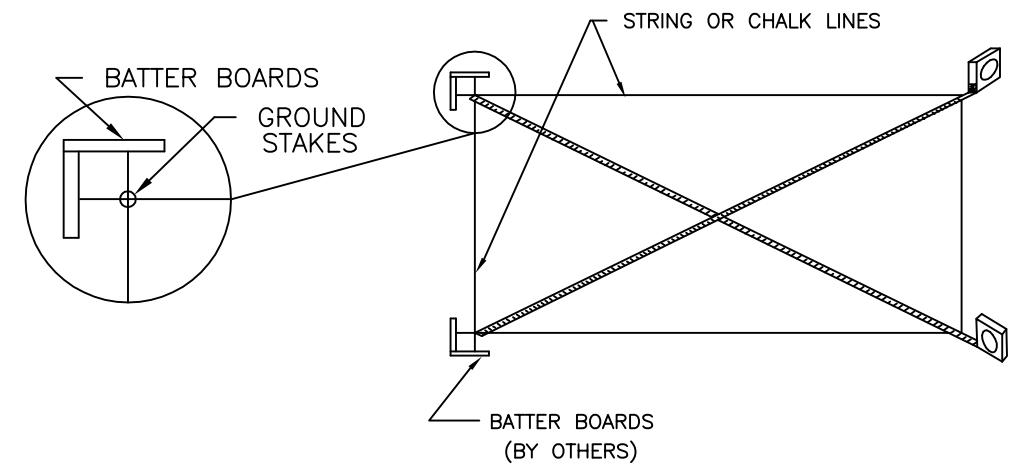

DRAWING A

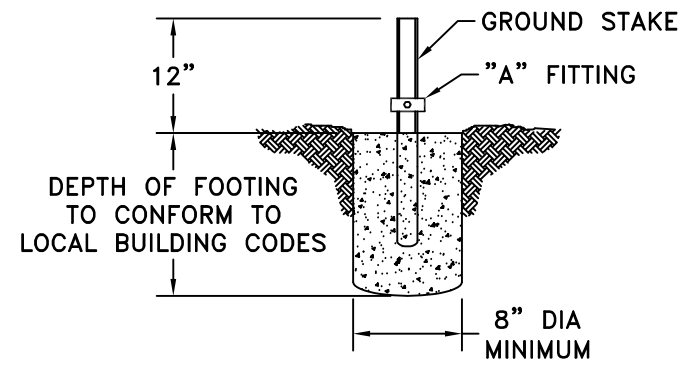

GROUND STAKE ANCHORING METHOD
DRAWING B

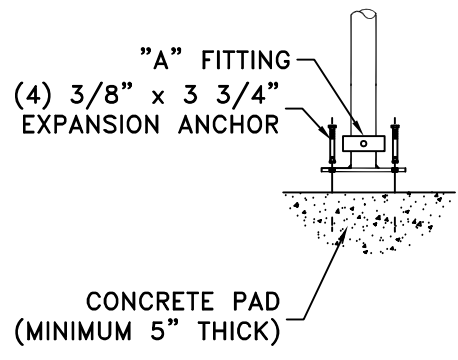

BASE PLATE ANCHORING METHOD
DRAWING C

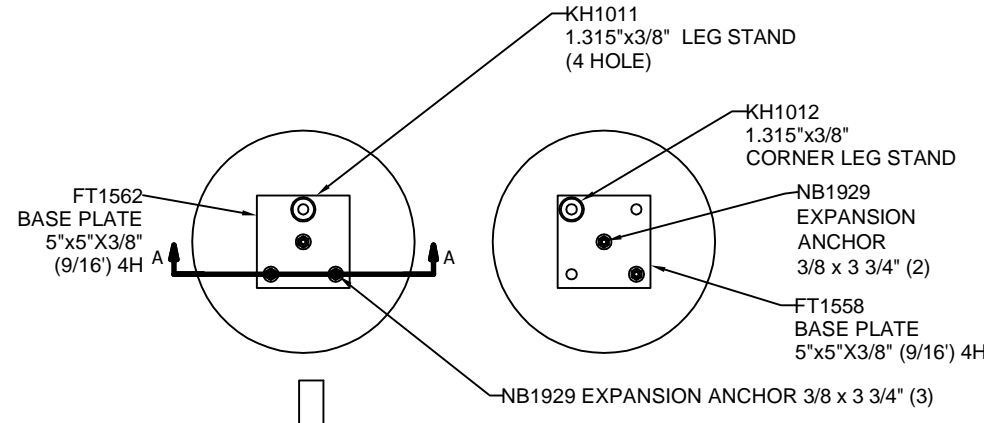

SECTION A-A
DRAWING F

ALTERNATELY: PLATE MAY BE ANCHORED TO A 5" MINIMUM CONCRETE SLAB.

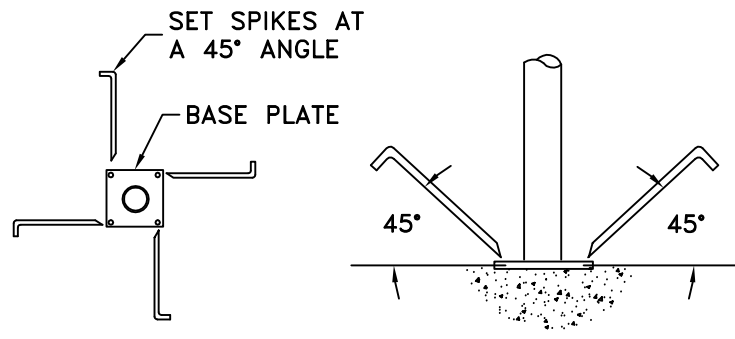

SPIKE ANCHORING METHOD
DRAWING D

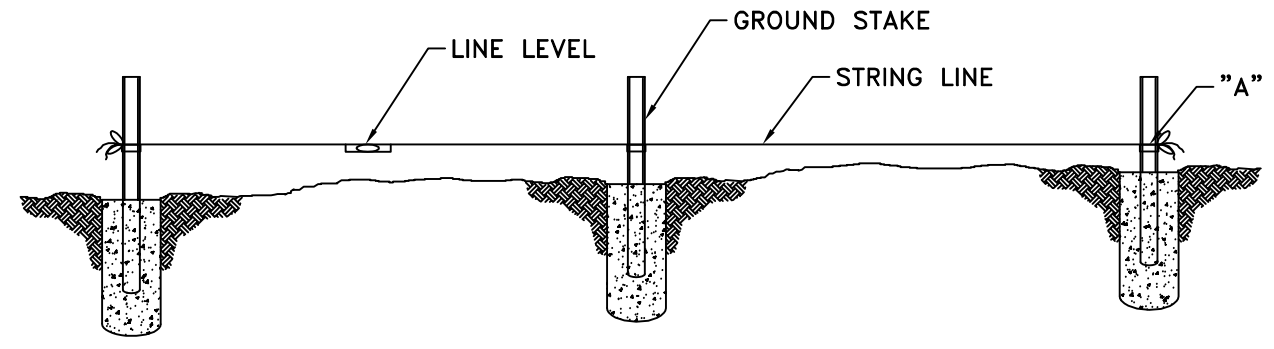

DRAWING E

Lay hoop section out on the ground as shown. Slide top hoop over straight hoop section until snap button sets into position. Insert HC Peak Connector between both top hoop sections, insuring the snap buttons set into proper positions.

If your Hava Cabana uses Gable End Frames, please refer to Page Five for additional information.

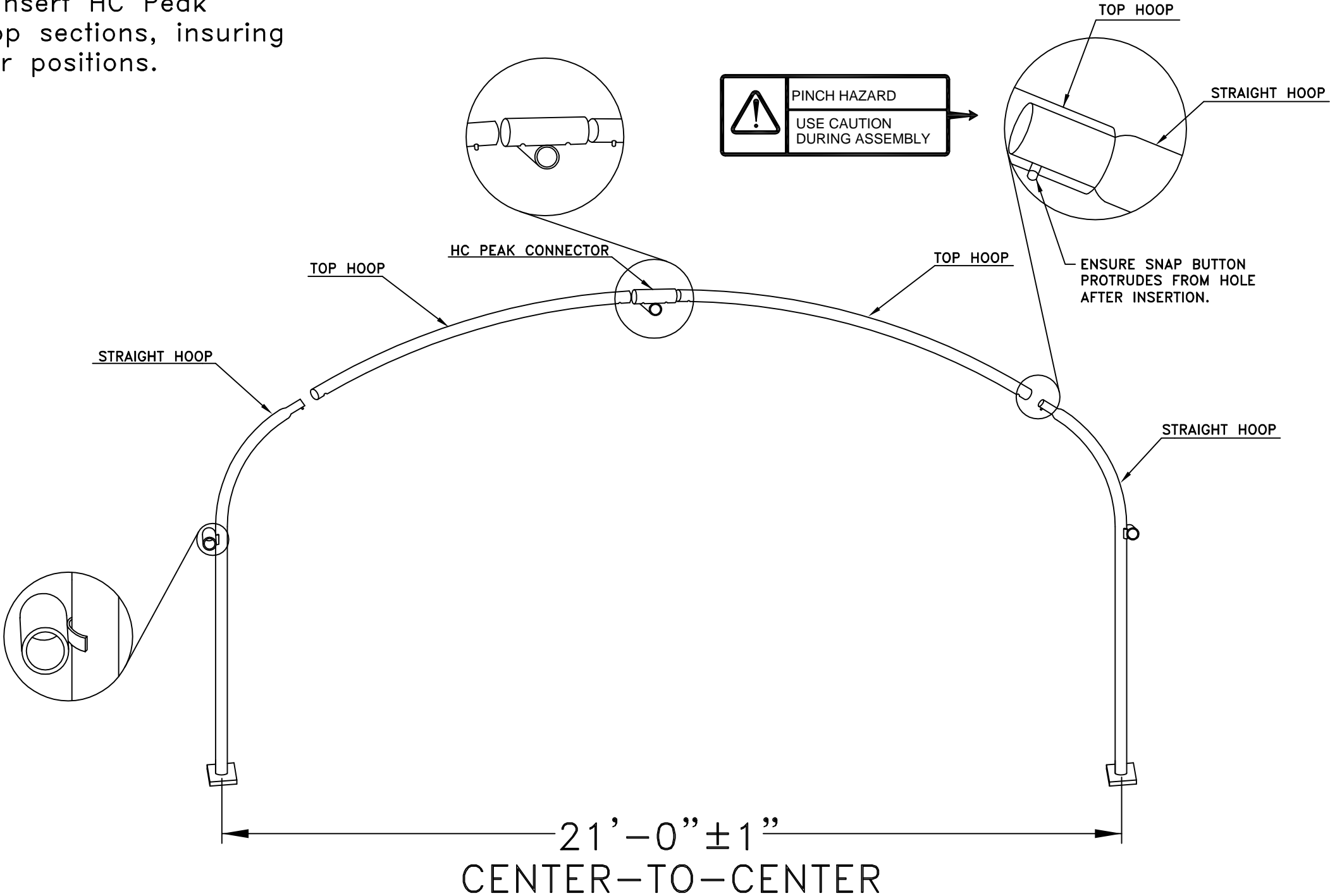

Raise the first 2 hoop sections and install the diagonal struts. Secure hoop sections to ground stakes or leg stands (if used) at this time with (1) 1/4"-14 x 1" Self-Drilling screw. (See drawing A) Diagonal struts are secured with (2) long speed hooks and carriage bolts, lock washers, flat washers, and hex nuts (See drawing B). Next, install the ridge and side purlins. The ridge purlins are secured with (2) 5/16" X 3/4" hex head bolts (See drawing C). The side purlins are secured with (2) 5/16" x 3/4" hex head bolts (See drawing D).

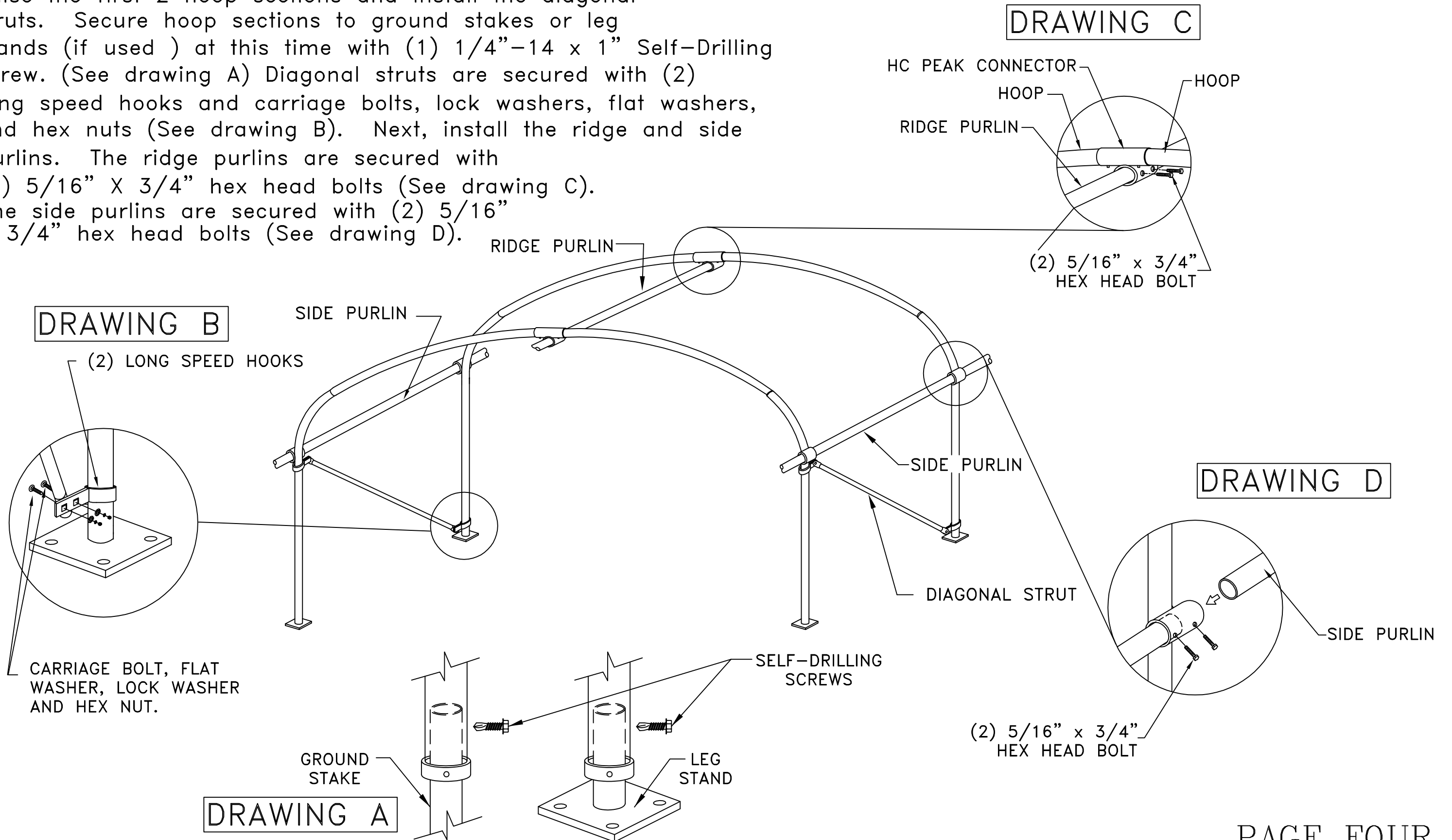

GABLE END FRAMING (OPTIONAL)

If the structure has gable end curtains you will have to install an end wall extension, (1) gable end vertical and (2) end frame trusses. First attach the end wall extension to the "HC" Peak Connector w/tab using a carriage bolt (See drawing A). Then install the gable end wall vertical to the End Wall Extension insuring snap button is in proper position.

NOTE: Make sure the "H" fitting has been installed before installing the End Wall Vertical. Now install the end frame truss to the "H" fitting and long speed hooks (See drawing B and C).

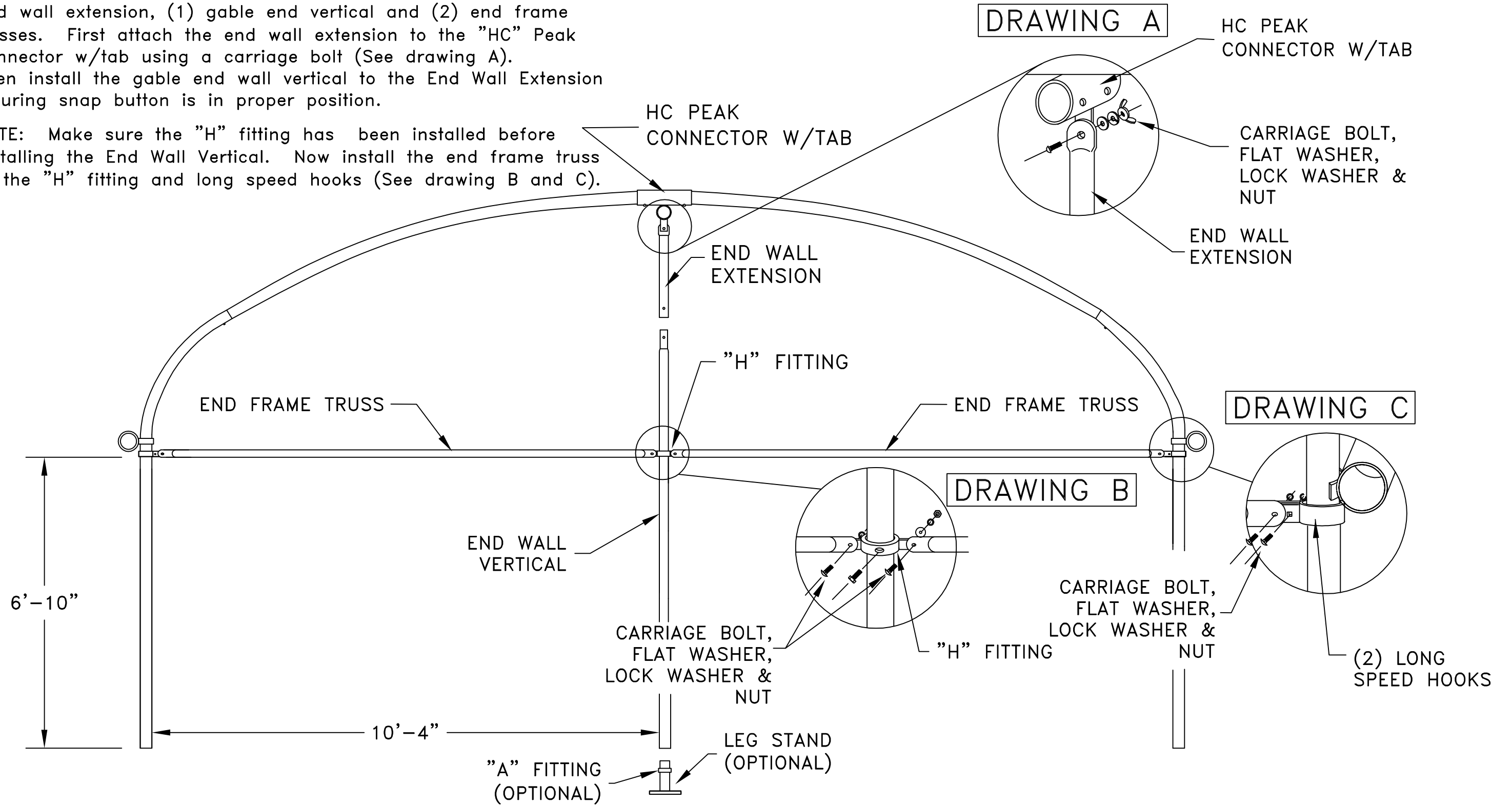

ATTACH ALL APPLICABLE VINYL PANELS USING BUNGEE BALLS.

NOTE: IT IS NORMAL TO HAVE A 3" GAP AROUND THE TOP COVER AND THE FRAME.

