

KOOL MART

INSTALLATION INSTRUCTIONS

with roll-up sides

NOT FOR CONSTRUCTION.
Refer to manual provided with
materials used for installation



Poly-Tex Inc.
27725 Danville Avenue
P.O. Box 458
Castle Rock, MN 55101

US & Canada Toll Free
800-852-3443
(651) 463-7009
fax (651) 463-2479



SAFETY GUIDELINES

PLEASE READ THE INSTALLATION INSTRUCTIONS CAREFULLY BEFORE ASSEMBLING THE STRUCTURE. SAVE THESE INSTRUCTIONS FOR FUTURE REFERENCE.

WARNING

This structure is intended to be self-supporting once constructed with all frames, hardware, sheathing, sheeting, bracing, cables, and membrane in place and secured to the foundation as shown in the manual. Stability during construction, from winds and loads imposed during erection, is the sole responsibility of the installer. Observe safety codes required by your jurisdiction, and relevant safety practices for working at heights. Avoid the risk of electrical shock from overhead lines or electrical storms. Poly-Tex recommends contracting a licensed electrician to perform electrical work. Eye protection is recommended under all circumstances and hearing protection is recommended when cutting components with power tools.

Foundations

These instructions include minimum guidance for foundations based on the International Building Code. These minimums are suitable for some areas of the country but not all. Obtain a building permit if required in your jurisdiction. Engineered Certified foundation plans may be required by a building official before issuing a permit. Even if not required, seeking guidance from a qualified structural or civil engineer for the foundation design may improve the life of the structure.

DANGER

No part of this structure is engineered to function as an anchorage point for a fall arrest system. Use a safety net or work from a safe work platform (i.e. scaffolding). Select a calm day for work. Wind can be sufficient enough to knock materials or workers off a work platform or ladder, resulting in a potentially deadly fall.

Overview of assembly procedure

While each structure and site is unique, and may require special considerations, these instructions are for a tilt-up method (where frames are assembled on the ground and tilted onto ground stakes or anchor rods using ropes or lifts). If installer is not confident to erect the structure, Poly-Tex suggests you hire a general contractor, carpenter, or similar licensed business familiar with construction to assemble and erect the structure.

DANGER

Do not overload structure. Consult with a Poly-Tex representative prior to adding any amount of weight over the specified capacity of this structure. Basket purlins, shelving or any objects of significant weight shall not be hung, attached, or secured to roof or truss members in a manner that will overload the structure.

WARNING

Do not walk on polycarbonate sheets. If the structure is to be covered with polycarbonate sheets, always use scaffolding for the erection process to avoid damage to sheeting and to ensure safety. Polycarbonate sheeting has UV coating protected with vinyl film on the exterior surface. Install sheets with the film intact and toward the exterior. Remove film once the sheet has been fastened in place.

KOOL MART

With Roll-up sides

INDEX

Part Identification.....	1
Part Identification.....	2
Layout & Base Assembly.....	3
Frame Section Assembly.....	4
Stand up Frame Sections.....	5
Door Installation.....	6
“V” Bracket & Basket Purlin.....	7
Basket Purlin & “V” Bracket & Ballast Frame.....	8
Concrete Block Installation.....	9
Water Tube Installation.....	10
Retro Roll-Up Side Application.....	11
Wiggle Base Rails & End Poly Installation.....	12
Roll-up Curtain Attachment.....	13
Guide & Roll-up Assembly.....	14
Poly Installation.....	15

PART IDENTIFICATION

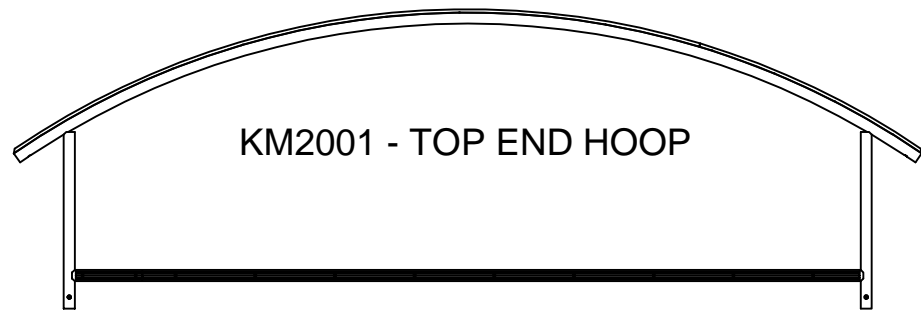

KM2001 - TOP END HOOP

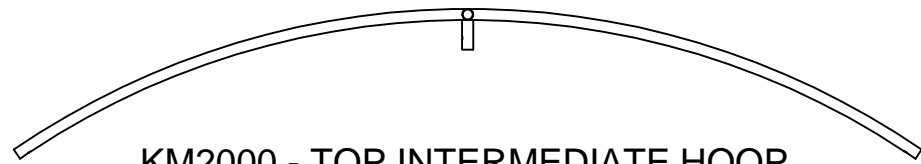

KM2000 - TOP INTERMEDIATE HOOP



KM2005 - TOP END HOOP W/TABS



KM2030 - INTERMEDIATE HOOP

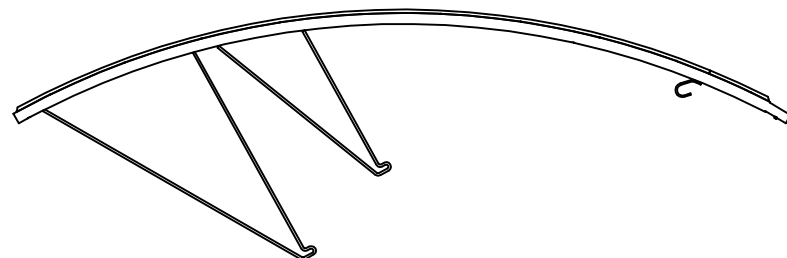

KM2031 - END HOOP W/WWB

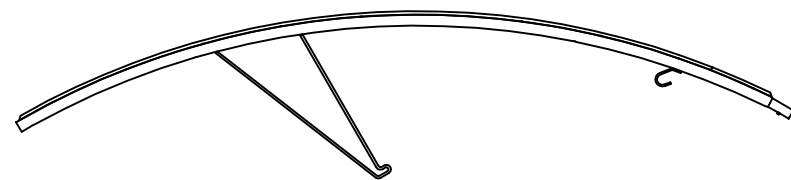

KM2016 - END HOOP W/WWR (BALLAST)

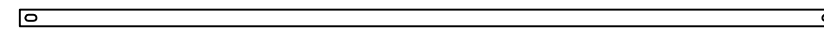

KM2008 - 6' DOOR SPACER

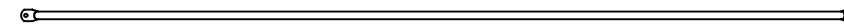

KM2021 - ROLL UP DOOR PIPE (126")

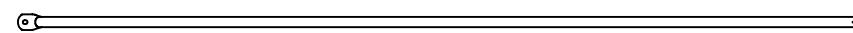

KM2010 - SLIDING DOOR END BRACE (95 1/2")

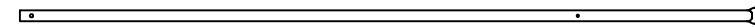

KM2009 - SLIDING DOOR VERTICAL

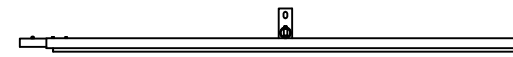

KM2032 - 6' SIDE BASE

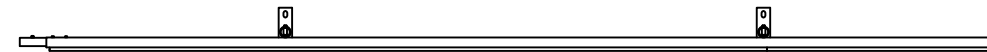

KM2033 - 12' SIDE BASE

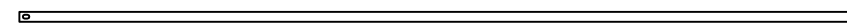

KHR1018 - DOOR SPACER



KHR1036 - DOOR JAMB

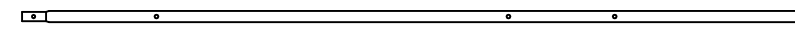

KHR1040 - POWER POLE

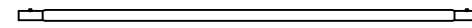

KHR1044 - RIDGE PURLIN

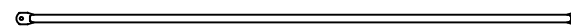

KHR1046 - DIAGONAL BRACE (85 1/2")



KM2040 - ROLL-UP CURTAIN GUIDE (KM)

KM2035 - LEFT CORNER BASE (ROLL-UP)

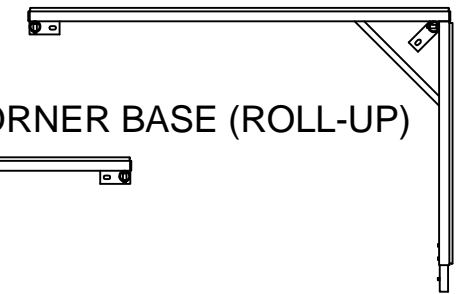

KM2034 - RIGHT CORNER BASE (ROLL-UP)

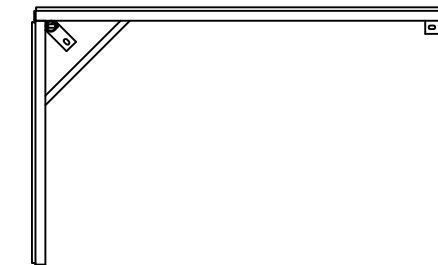

KM2029 - LFT CRN BASE (SLIDING DR, ROLL-UP)

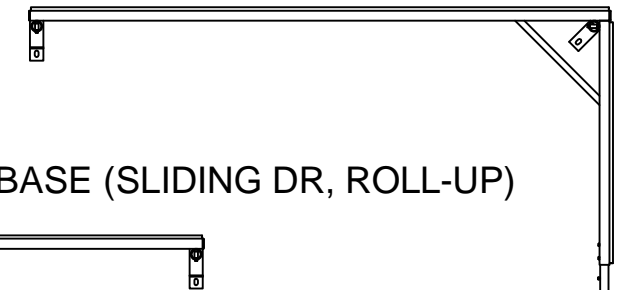

KM2038 - RT CRN BASE (SLIDING DR, ROLL-UP)

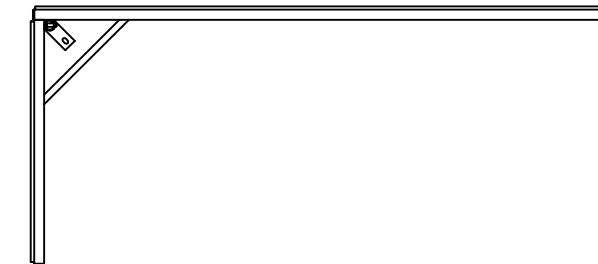

KM2037 - LFT CRN BASE (NO DOOR, ROLL-UP)

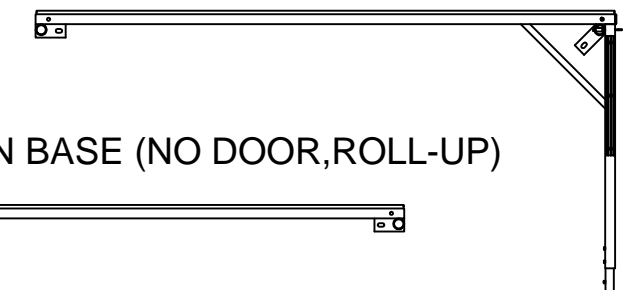

KM2036 - RT CRN BASE (NO DOOR, ROLL-UP)



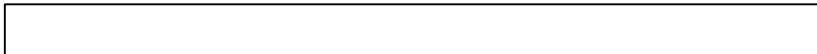

PART IDENTIFICATION

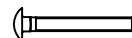

NB1816 - 5/16" x 2 1/2" CARRIAGE BOLT



NB1832 - 5/16" x 1 1/4" CARRIAGE GRD 5



NB1862 - 5/16" LOCK WASHER



NB1927 - CUSHION BALL



NB1872 - 5/16" HEX NUT



NB1901 - 3/8" WING NUT



NB1923 - NYLON WASHER



NB1924 - 5/16" x 1" THUMB SCREW

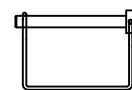

NB1925 - SNAPPER PIN



FT3200 - FLAT STACKER CLIP

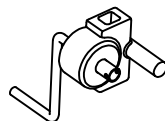

MV1000
MANUAL ROLL UP UNIT NS101

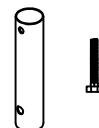

RC1009
GEARBOX EXTENSION W/BOLT



RC1010
ROLL-UP TUBE CLIP 1.315"

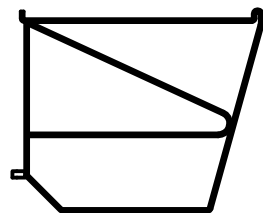

KM2015 - 36" KM BENCH FRAME

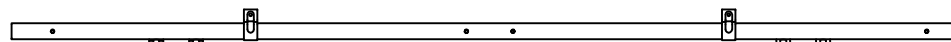

GM2802 - ROLLING DOOR RAIL



WIGGLE WIRE™



BMS1130 - 18" SPIKE



GM2803 - ROLLING DOOR HEADER

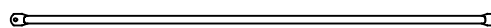

GM4000 - 6'-1-1/2" BASKET PURLIN -95



FT2080 - 1.66 HOOK



FT2087 - 1.66 INLINE SPEED HOOK



GM2970 - HOOP PAD

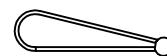

PT2521 - 10" BUNGEE BALL

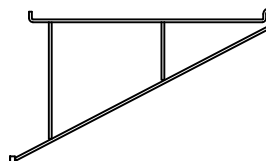

KM2004 - 36" KM BENCH BRACKET

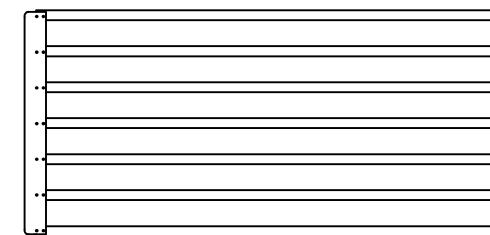

RF2552 - 3' x 6' BENCH TOP

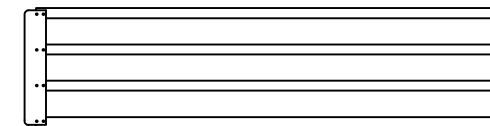

RF2554 - 1'6" x 6' BENCH TOP

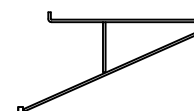

KM2003 - 24" KM BENCH BRACKET

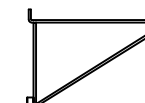

BMS1120 - 18" V BRACKET

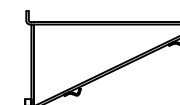

KHR1048 - HANGING BASKET "V" BRACKET

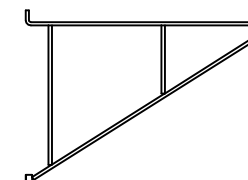

BMS1121 - 36" V BRACKET

LAYOUT & BASE ASSEMBLY

BASE ASSEMBLY

To assemble the base, connect corner bases, six foot side bases, and twelve foot side bases to length of greenhouse. These are secured together with snap buttons incorporated with the part.

Note: Not all KOOL MART's will contain a 6' base.

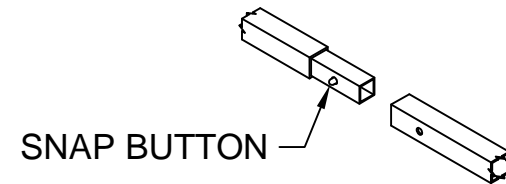

SQUARE THE BASE

When measuring the width of the greenhouse, measure from center-to-center of 5" inserts. The width should be 20'. Also measure diagonally across the base from corner-to-corner to make sure that the base is square.

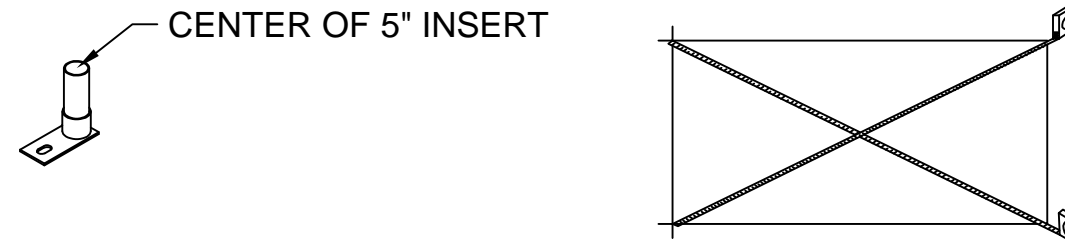

FINAL BASE ASSEMBLY

After you have assembled and squared the entire base of the KOOL MART, drive one 18" spike through the hole in each plate that accompanies the 5" insert.

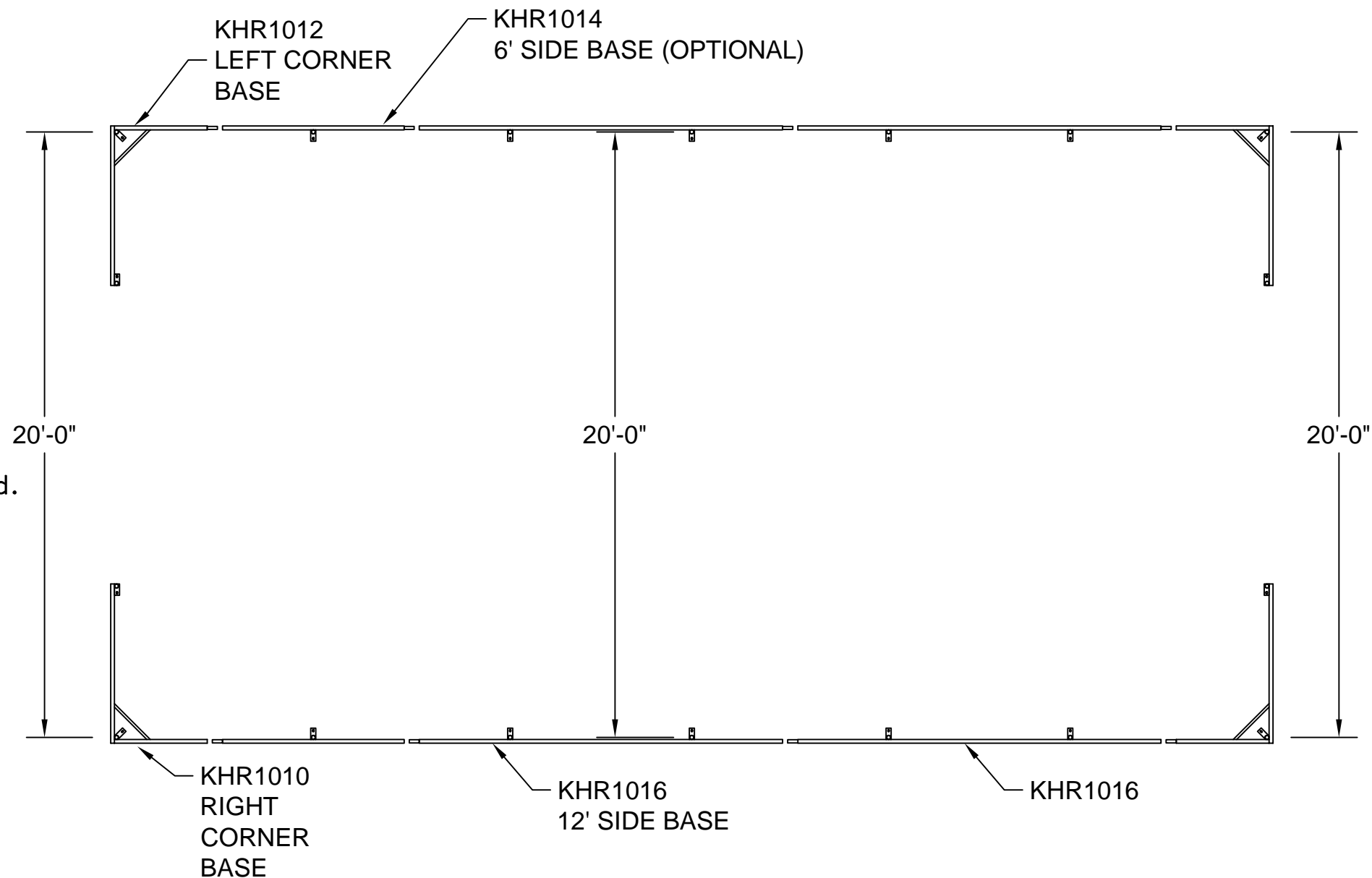
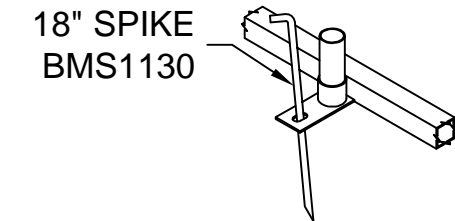

NOTE:
It is very important that the structure is installed on a level site, otherwise the strength of the assembly may be compromised.

Lay parts out on a flat surface, and assemble the End Frame Sections as shown (Door Sections shown).
 Make sure all snap buttons are secured.
 NOTE: Determine type of Door and assemble accordingly.

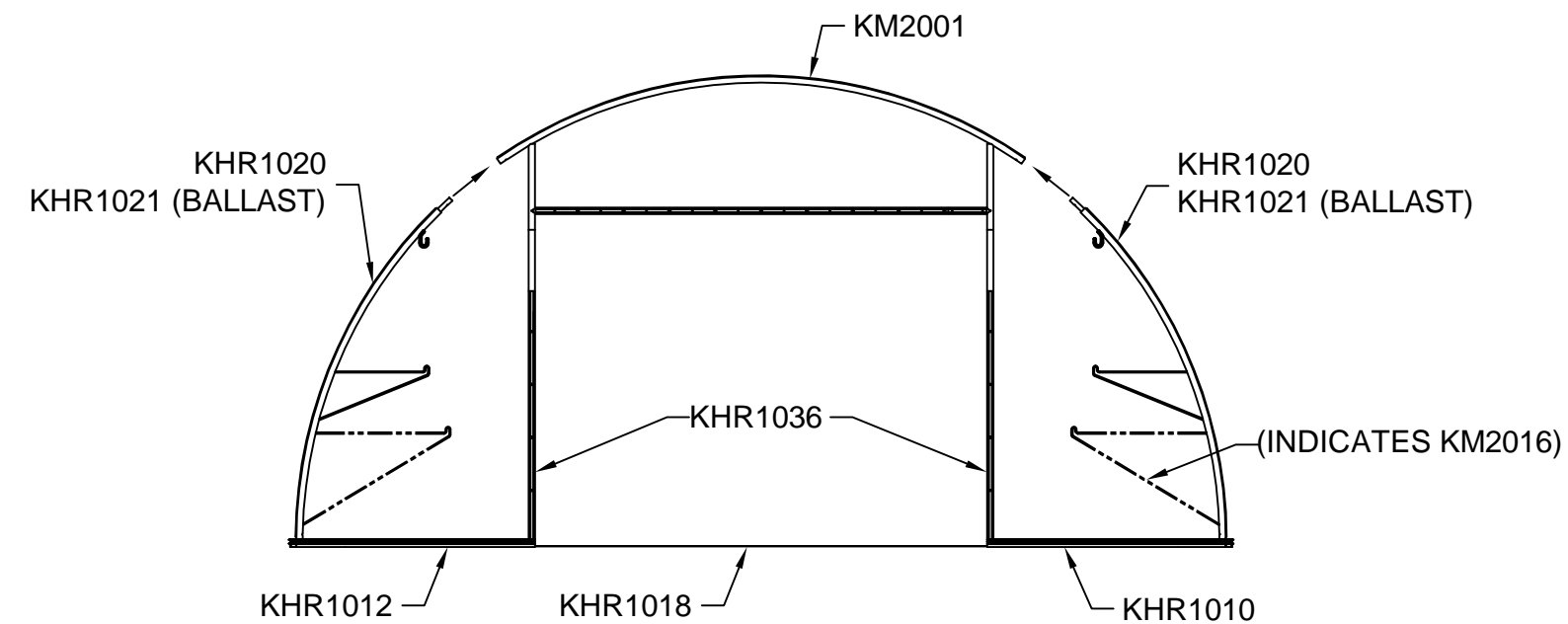

ROLL-UP DOOR END

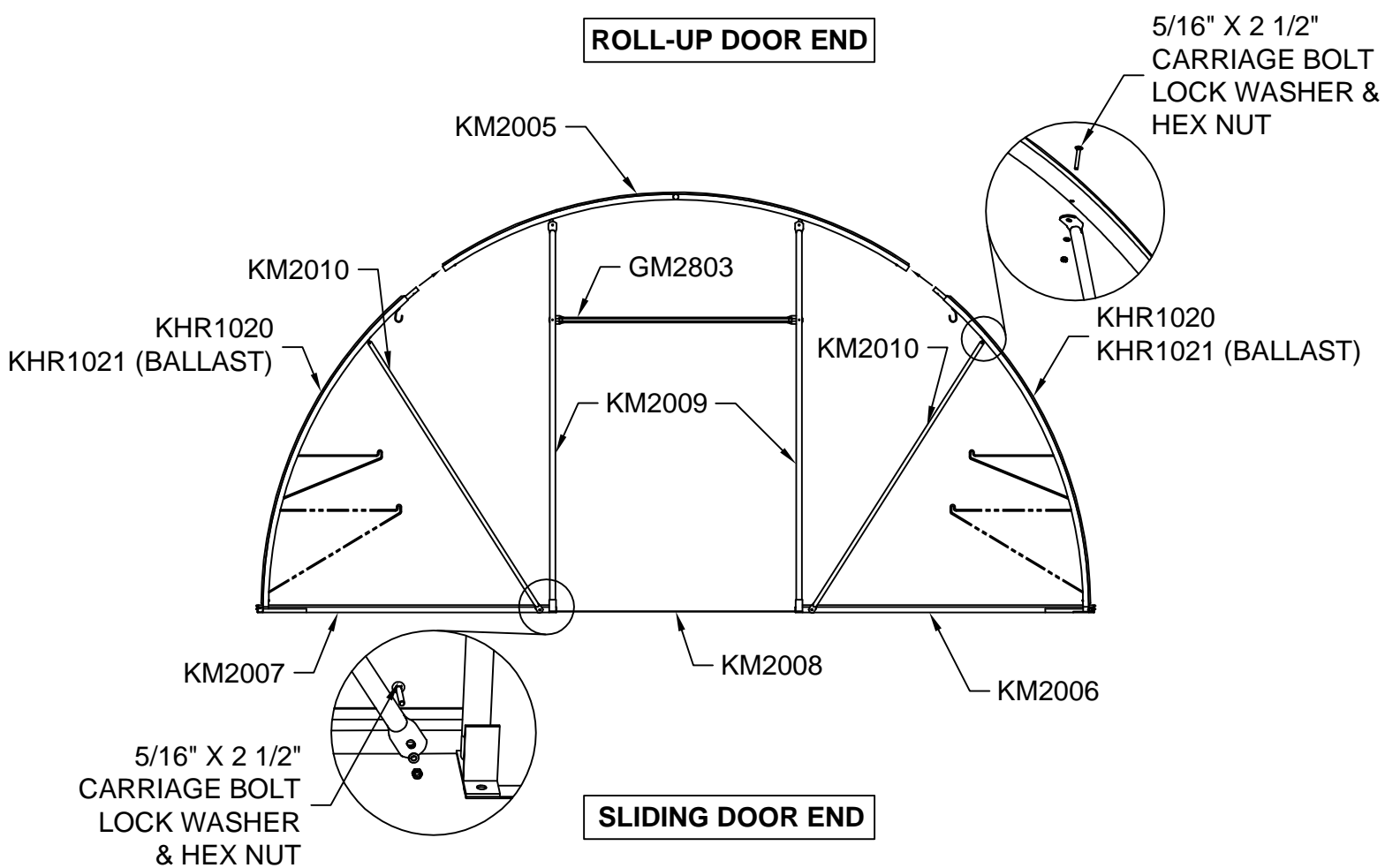

SLIDING DOOR END

Lay parts out on a flat surface and assemble the Intermediate Frame Sections as shown.
 Make sure all snap buttons are secured.

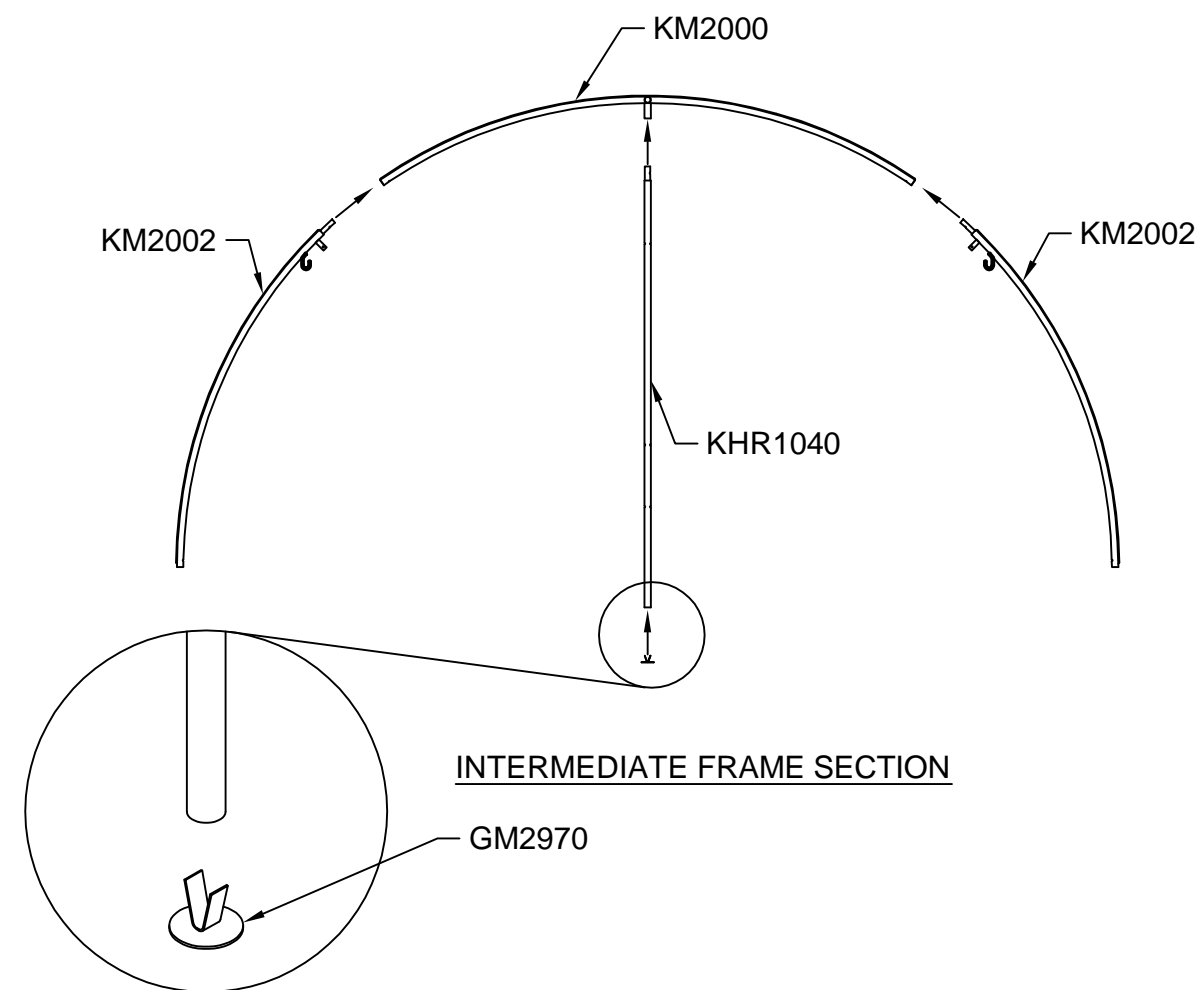

INTERMEDIATE FRAME SECTION

STAND UP FRAME SECTIONS

First, stand up one end frame section on the end 5" inserts.
Next, stand up an intermediate frame section on the next 5" inserts.
Then, insert a ridge purlin (KHR1044) between the peaks
of the frame sections.

Ensure all snap buttons are secured.

Attach diagonal braces (KHR1046) to each corner with long speed
hooks (FT2080), 5/16" x 1 1/4" carriage bolts, and 5/16" X 2 1/2"
carriage bolts. Tighten snugly.

Continue down the rest of the Kool Mart with intermediate frame
sections and ridge purlins. Finish with the frame section on the
other end.

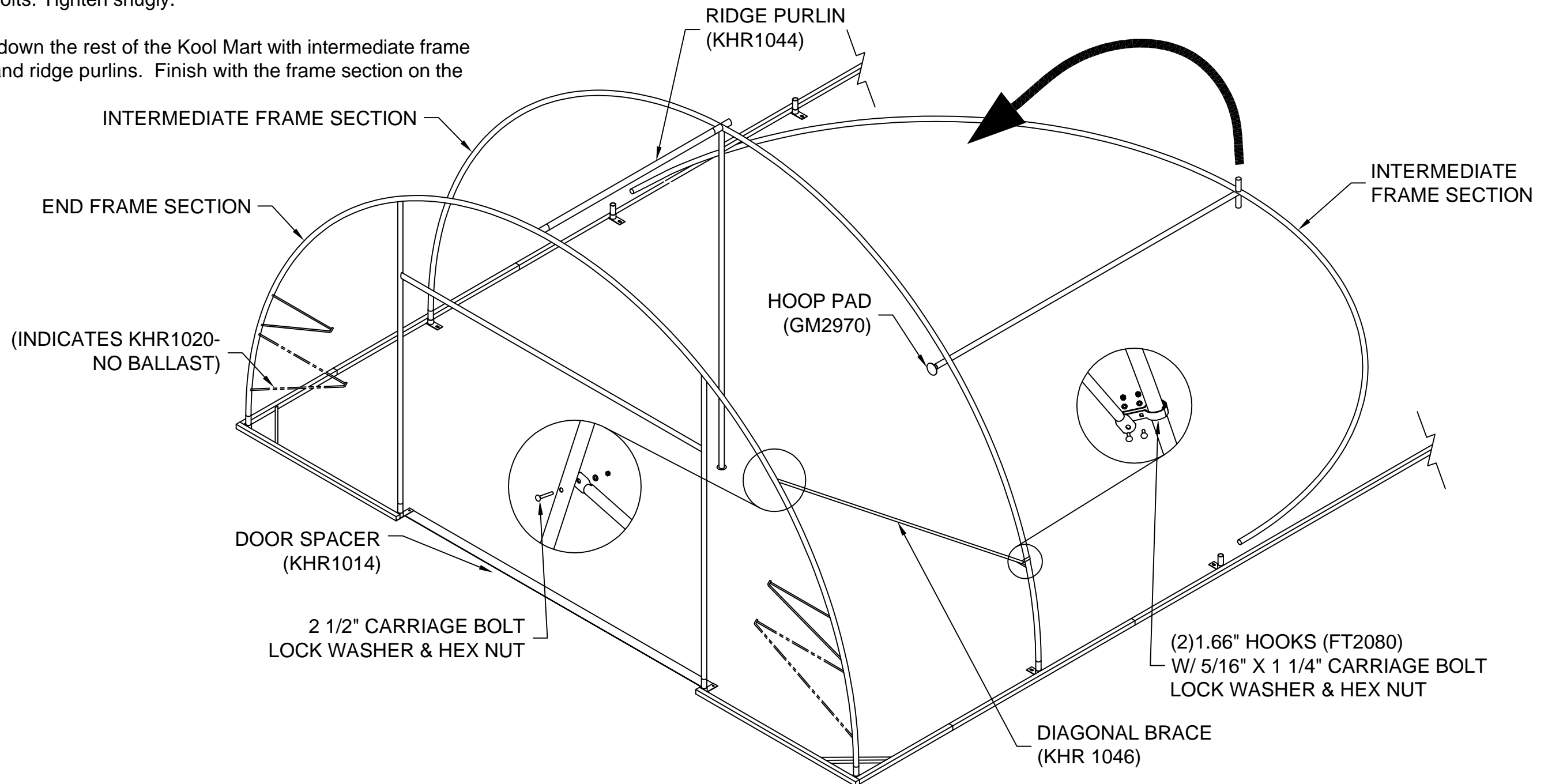

DOOR INSTALLATION

ROLL UP DOOR WITH ROLL-UP SIDES

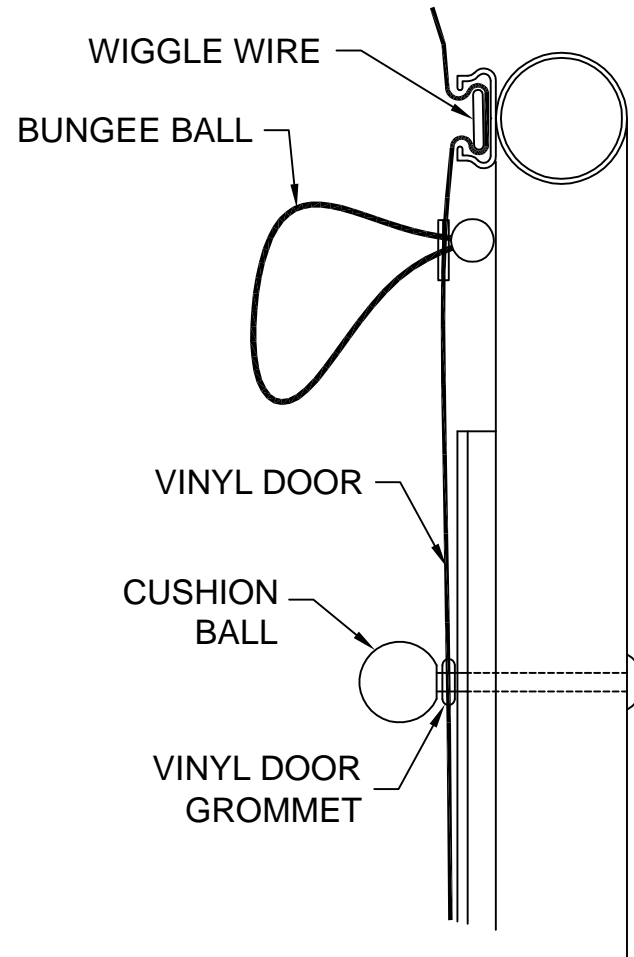
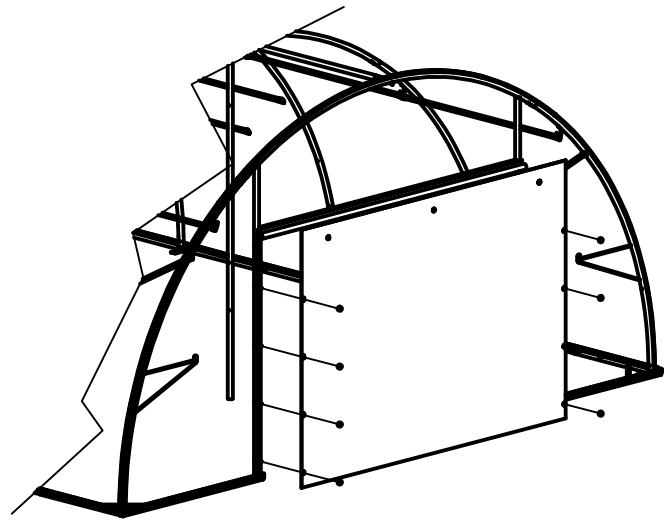

CLOSED VIEW

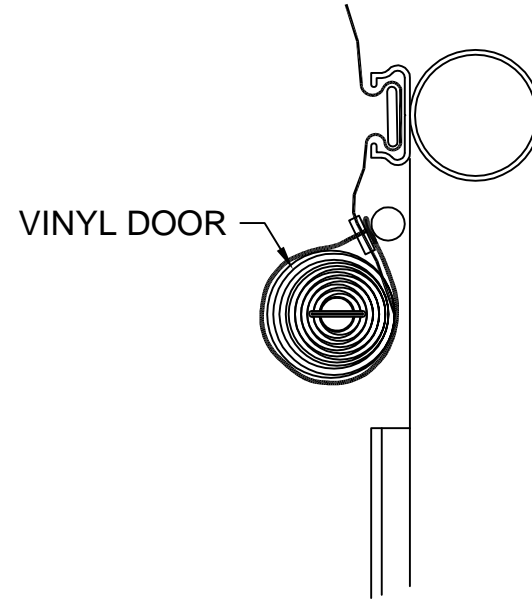

OPEN VIEW

1. Secure door to jambs using (6) cushion balls (NB1927) and carriage bolts.
2. Fasten top of door to header using wiggle wire.

To open door, remove cushion balls and place them where they can be found easily. Roll up door and secure inside bungee balls.

To close door, place grommets over bolt ends on the front of the door jambs and secure with cushion balls.

ROLL-UP DOOR

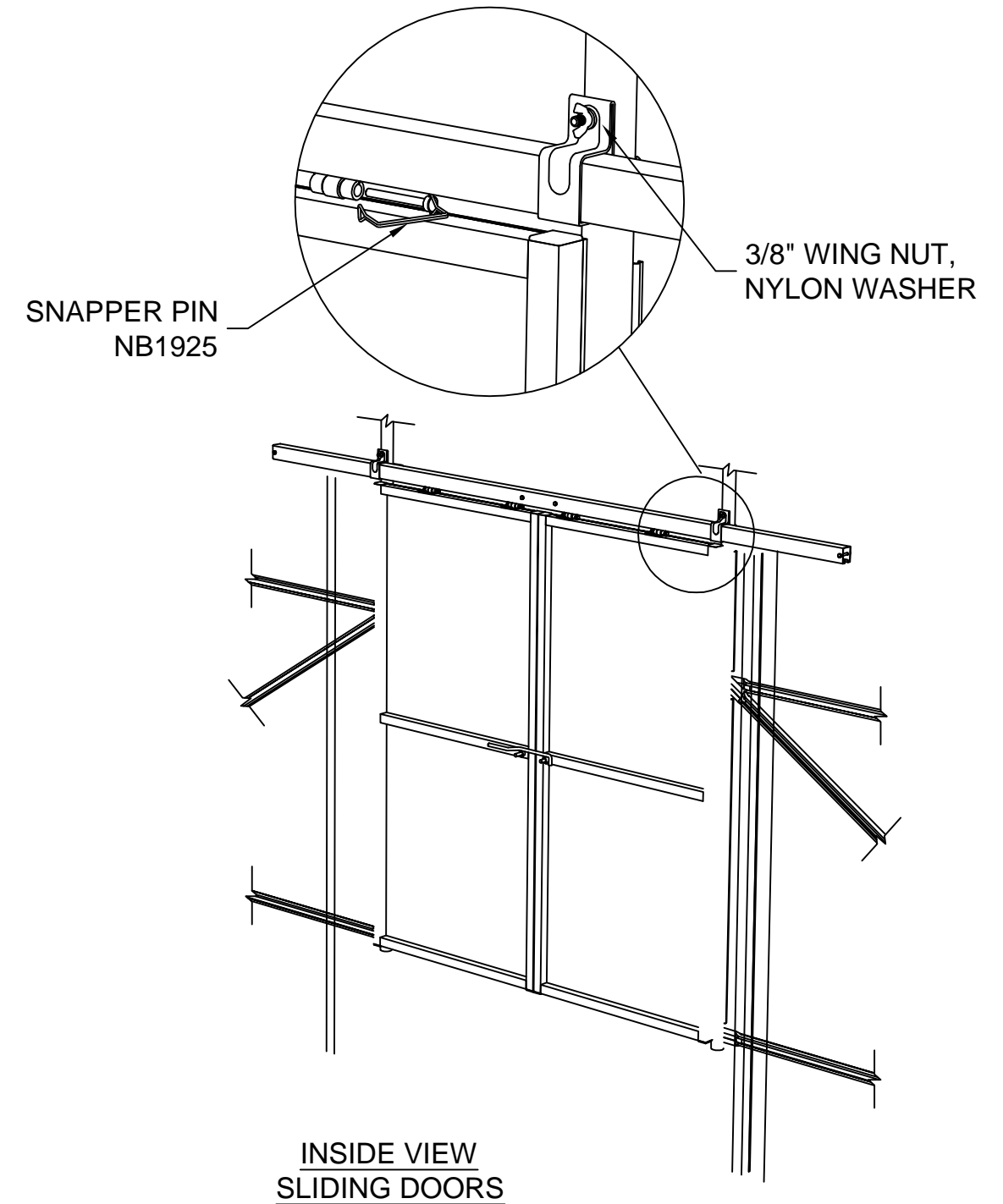

INSIDE VIEW
SLIDING DOORS

Refer to instructions included with the door latch kit to assemble latches to the doors.

"V" BRACKET & BASKET PURLIN

ROLL MAT WITH ROLL-UP SIDES

1. Install the "V" brackets onto the center poles and intermediate frame sections by inserting them into the pre-drilled holes.
2. Attach Inline fitting to power pole at approximately 84". Attach purlin to inline fitting and hoop tabs and adjust if necessary.
3. Install the basket purlin by hooking it on the basket purlin hooks.
4. Place bench tops on "V" brackets as shown.
5. Use flat stacker clips to secure bench tops to "V" brackets on each end of the four center benches using thumb screws.

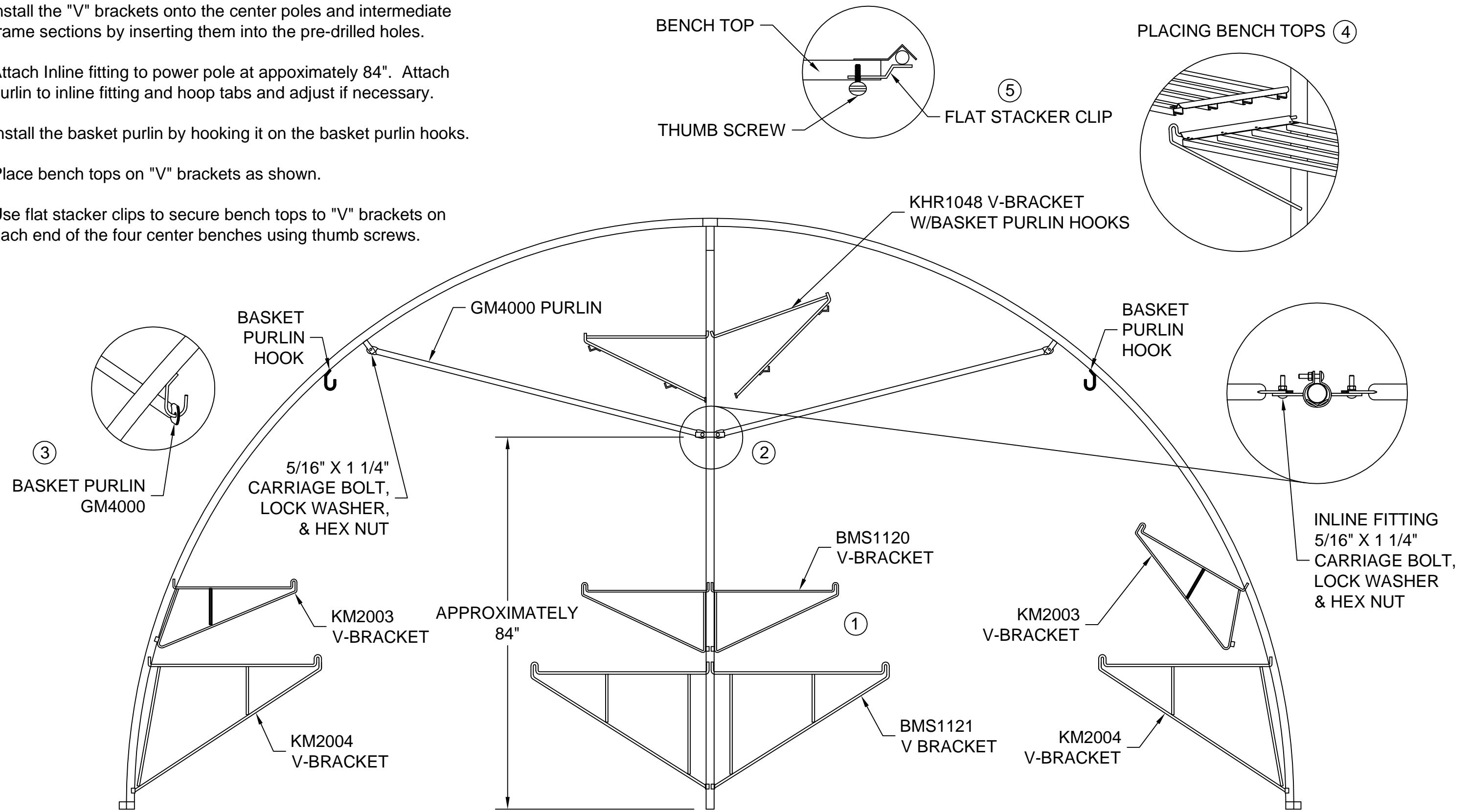

PLACING BENCH TOPS ④

⑤

③

②

①

BASKET PURLIN & "V" BRACKET BALLAST FRAME

1. Install the "V" brackets onto the center poles and intermediate frame sections by inserting them into the pre-drilled holes.
2. Attach Inline fitting to power pole at approximately 84". Attach purlin to inline fitting and hoop tabs and adjust if necessary.
3. Install the basket purlin by hooking it on the basket purlin hooks.
4. Place bench tops on "V" brackets as shown.
5. Use flat stacker clips to secure bench tops to "V" brackets on each end of the four center benches using thumb screws. See Page 9 for preferred ballast installation, and page 10 for alternate Water tube installation.

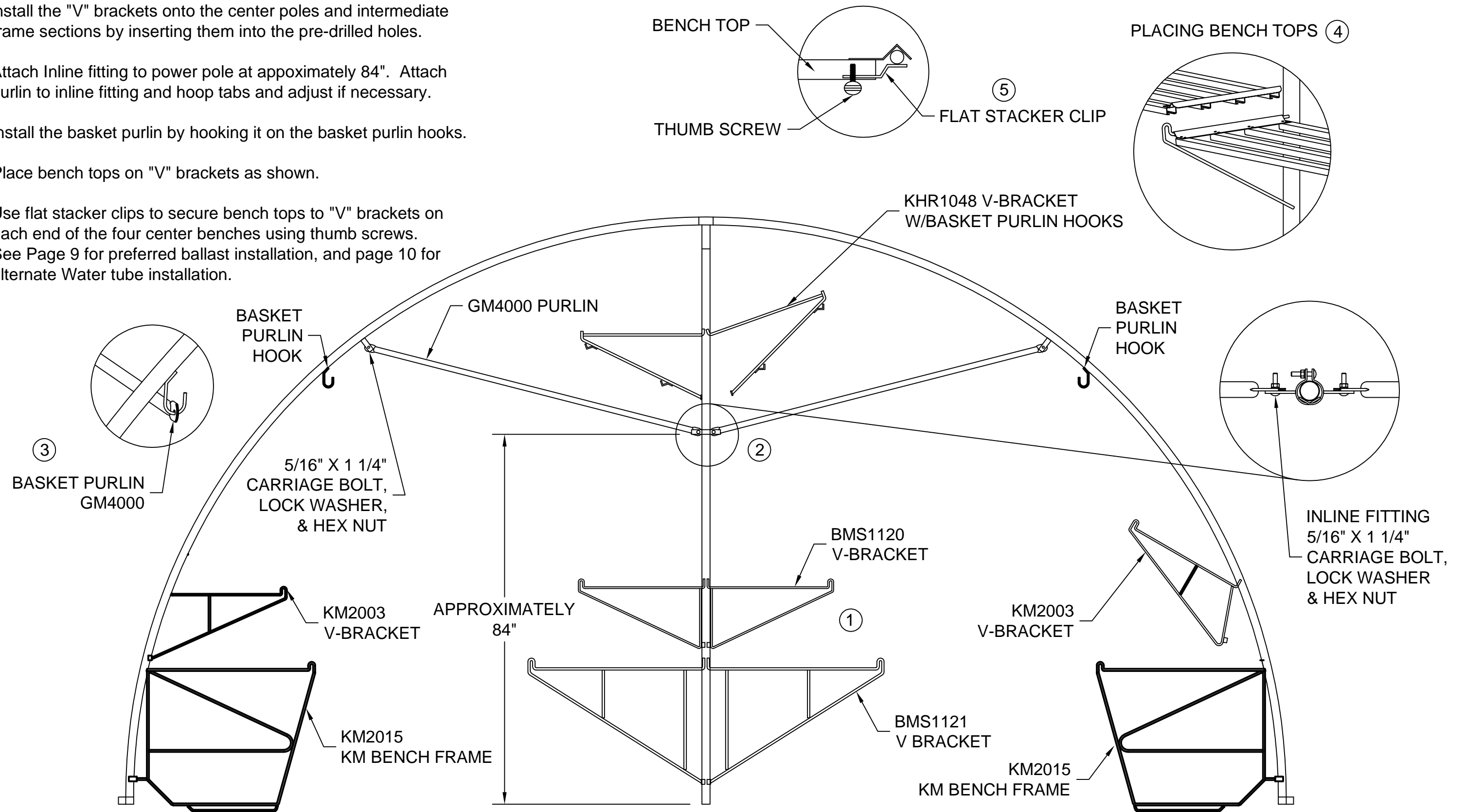

CONCRETE BLOCK INSTALLATION

KOOL MART WITH ROLL-UP SIDES

(OPTIONAL)

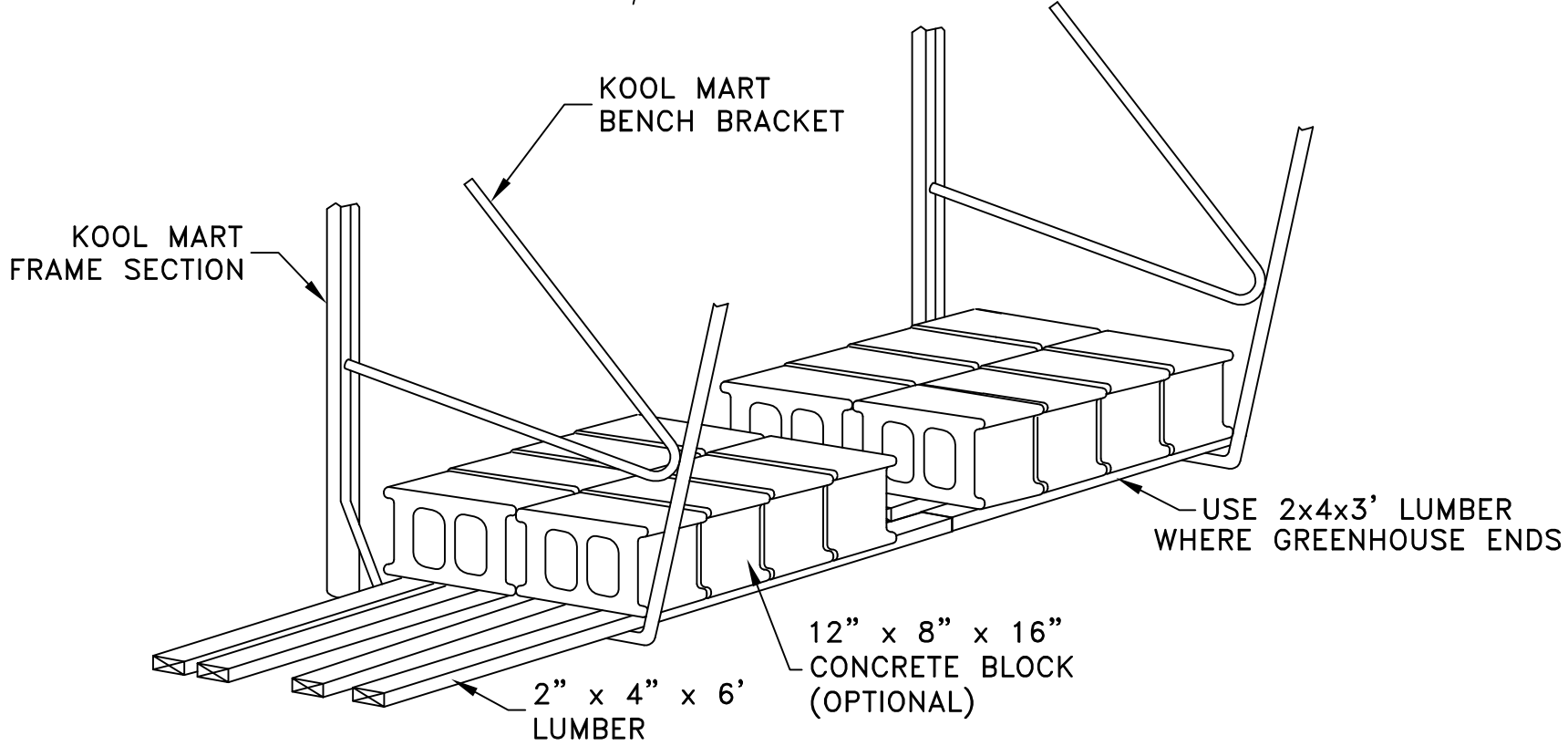
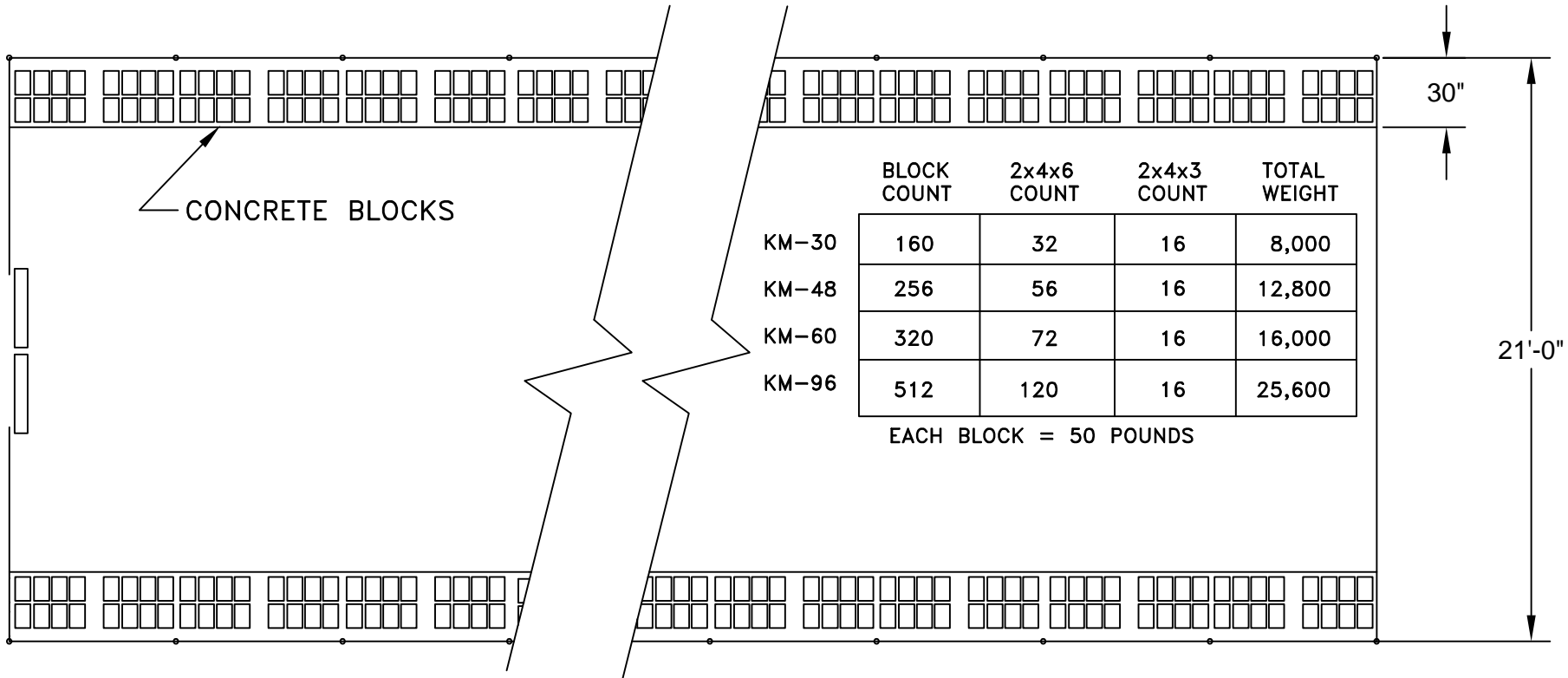

BENCH VIEW

WATER TUBE INSTALLATION

BALLAST OPTION

KOOL MART WATER WEIGHTS

MODEL KM-30	8,000 POUNDS OF WATER
MODEL KM-48	12,000 POUNDS OF WATER
MODEL KM-60	16,000 POUNDS OF WATER
MODEL KM-96	24,000 POUNDS OF WATER

KOOL MART WITH ROLL-UP SIDES

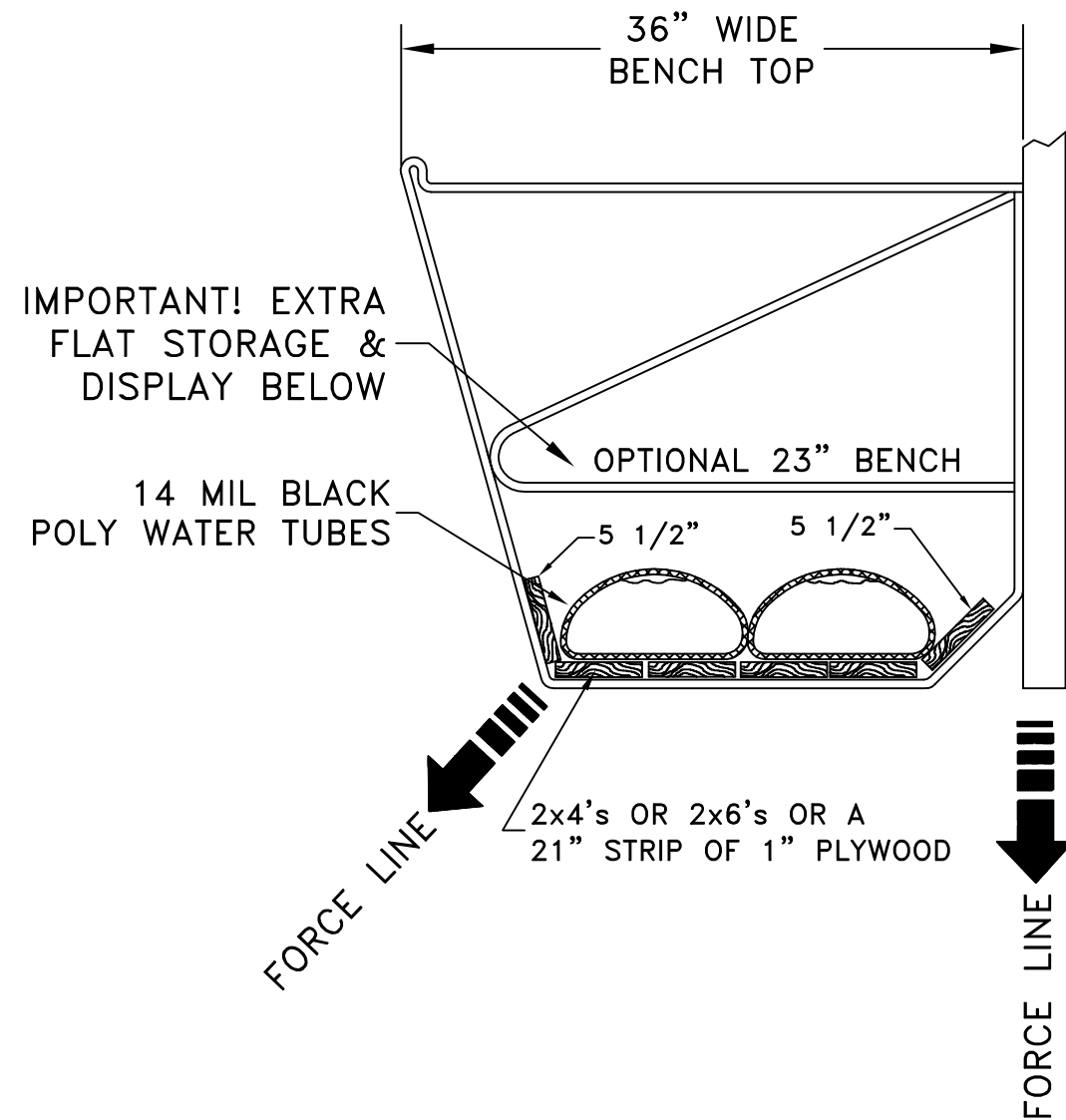

IMPORTANT NOTE:

LUMBER SUCH AS 2 x 4's, 2 x 6's OR 1" THICK PLYWOOD **MUST** BE USED TO HELP CONCENTRATE WATER TUBE WEIGHT OVER THE BENCH FRAMES.

DIVERTING FROM THIS PROCEDURE CAN CAUSE SERIOUS DAMAGE TO YOUR STRUCTURE UNDER WINDY CONDITIONS.

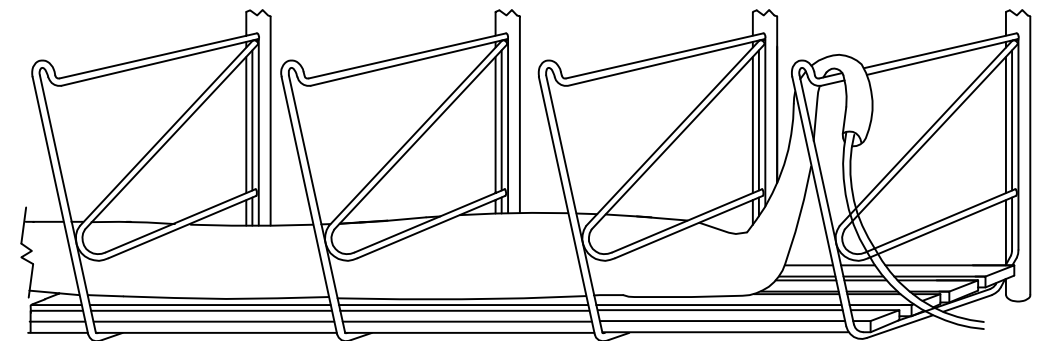

SIDE VIEW SHOWING LOCATION OF WATER TUBE

Unroll the black plastic water tubes and place them on top of the boards. Drape the open end up over the end bench frame and use a garden hose to fill the tubes. After the water tube is full, secure to the bench frame with large black cable ties as drawing indicates.

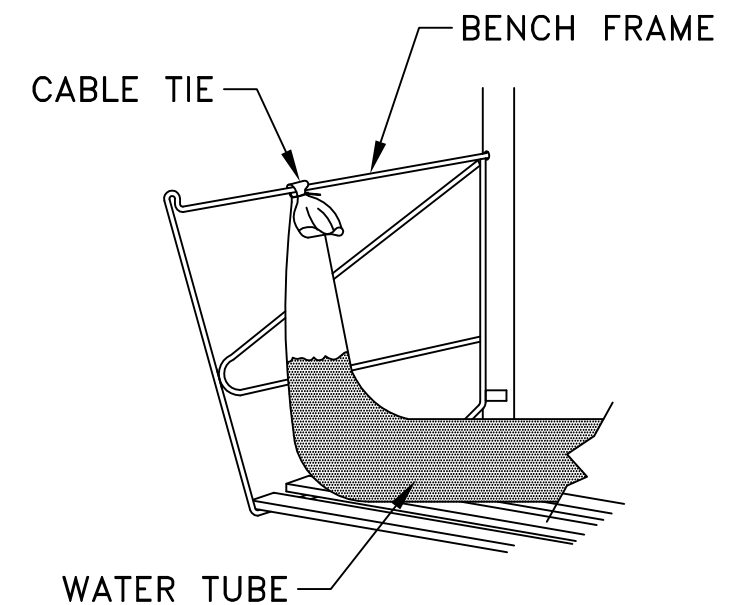

After the bench frames are installed, lay some common boards (2 x 4's or 1" plywood) on top of the lower bench tube. These will concentrate the weight of the water directly onto the bench tube.

RETRO ROLL-UP SIDE APPLICATION

NOTE: IF THIS IS A NEW CONSTRUCTION, SKIP TO PAGE SEVEN

1. After poly has been removed from the roof, remove screws and wiggle wire base from both sides of structure (FIGURE 1).
2. Place a mark at 55 1/4" from bottom of frame on each hoop (FIGURE 2).
3. Attach 18" wiggle wire base 3 1/4" from end to each corner using 2 #12-14 X 1" self-drilling screws (FIGURE 3).
4. Cut out 4" of wiggle wire base at each corner frame section at the mark placed in step 2 (FIGURE 4).
5. Attach stud hook and short speed hook at the mark measured in step 2 with the bolt and tab facing towards the inside of the greenhouse (FIGURE 5).
6. Attach the Roll-up Guide Bracket at each hoop using 2 #12-14 X 1" self-drilling screws (FIGURE 6).
7. Drill 1/2" hole 2" from end at each corner on one end to secure gearbox guides (FIGURE 7).

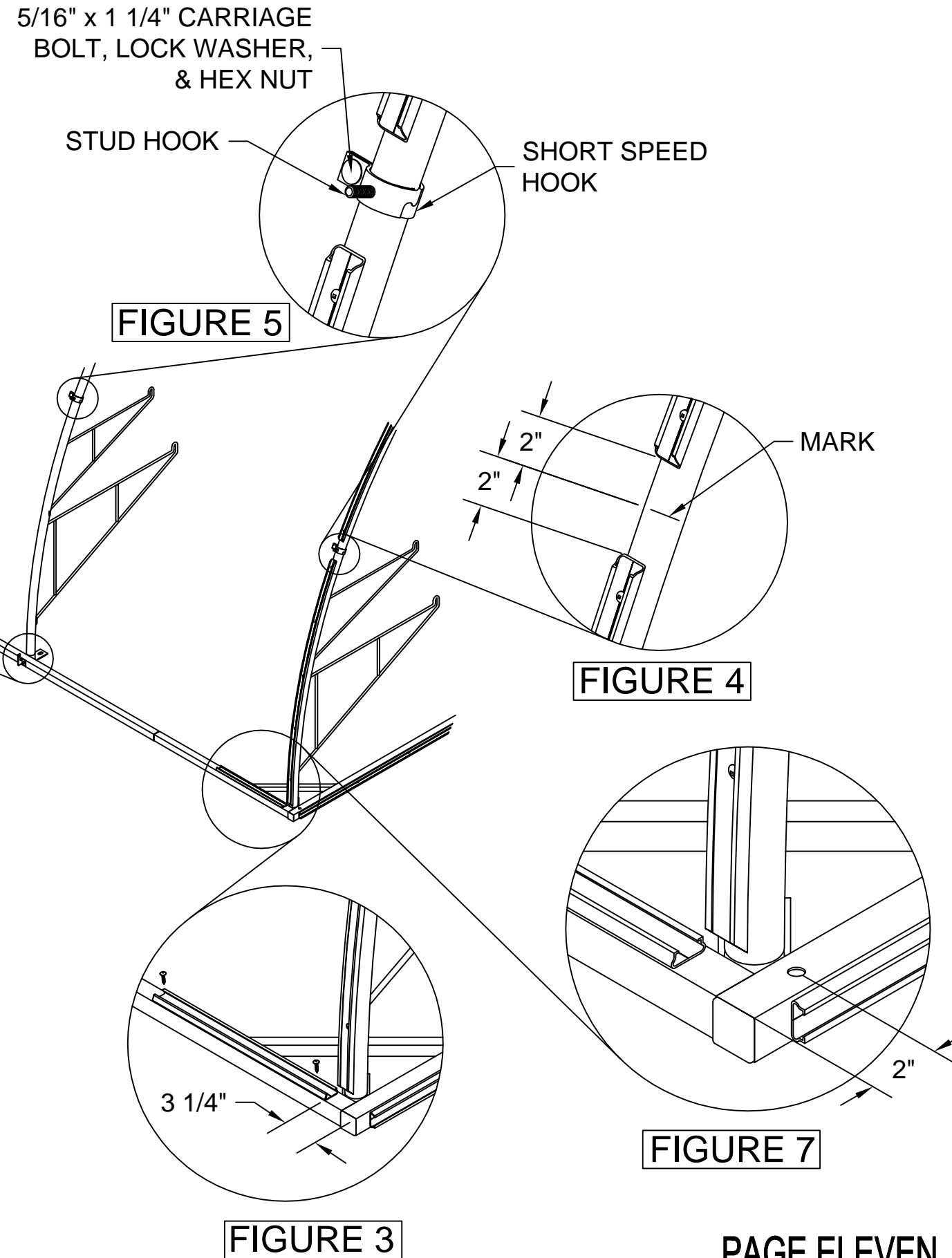
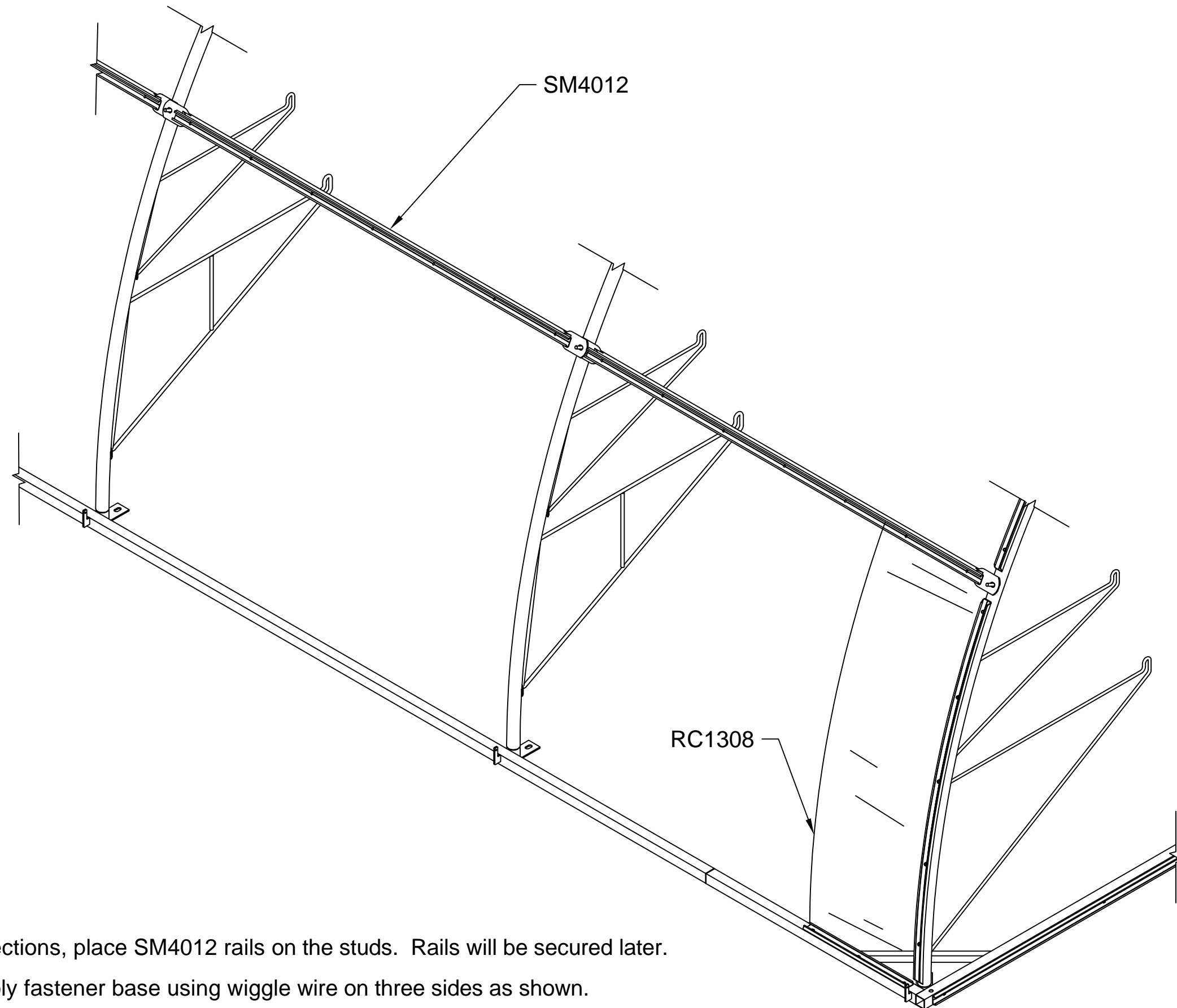

FIGURE 1

FIGURE 2

FIGURE 3

FIGURE 7

WIGGLE BASE RAILS & END POLY INSTALLATION

After installation of the frame sections, place SM4012 rails on the studs. Rails will be secured later.

Fasten end panel RC1308 to poly fastener base using wiggle wire on three sides as shown.

For ease of access, lay out nominal 5 foot wiggle wire pieces in handy locations along the side of the structure.

ROLL-UP CURTAIN ATTACHMENT

ROLL MARK WITH ROLL-UP SIDES

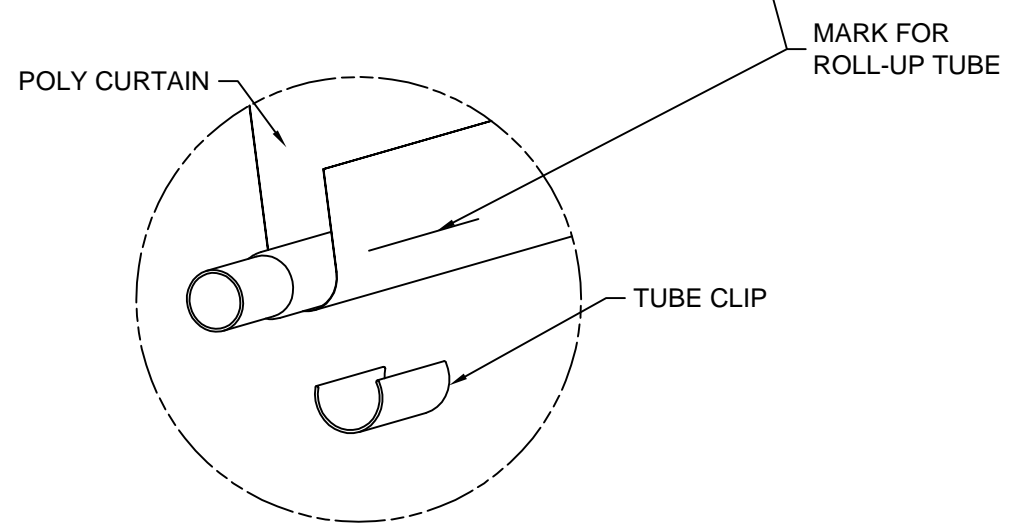
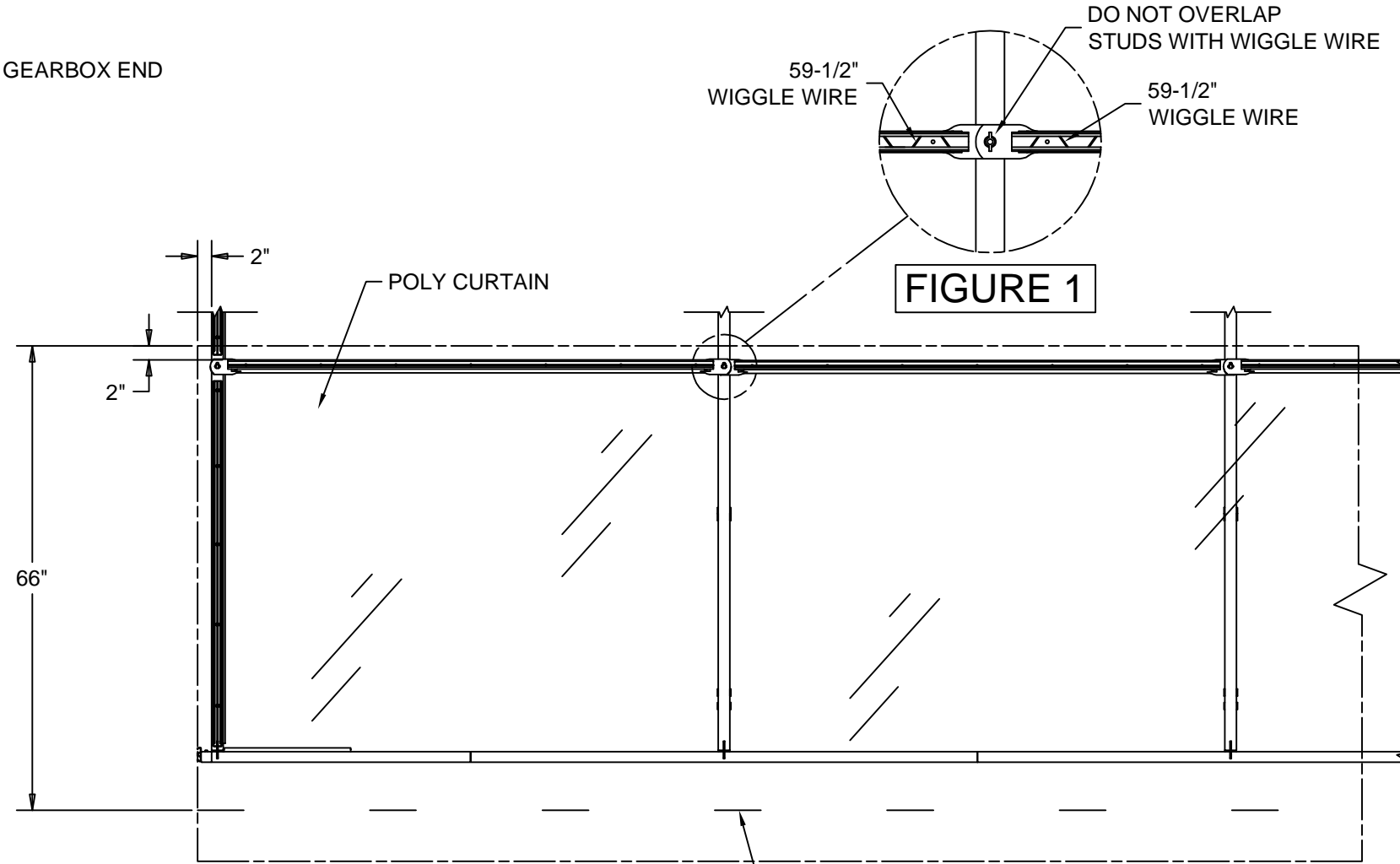
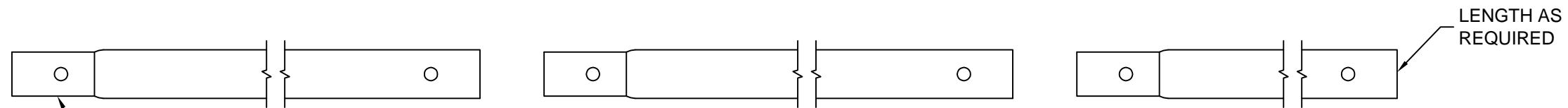

Unroll and position the "roll-up curtain" poly film along each side of the structure. Be sure to have equal excess film on both ends. For best results, work from the middle of the structure and move to the ends when securing the poly. Using the edge of the poly as a guide, raise the poly into place with about 2" above the rail and secure the poly to the poly fastener base using wiggle wire provided. Be certain the wiggle wire does not overlap studs see **FIGURE 1**. Tension the poly and maintain a minimum of 2" of poly excess above the poly fastener base. After the curtain is hung, using a blunt object, press all wiggle wire firmly into base to ensure it has been seated properly.

After the poly is secure, measure down 66" from the top rail and place a series of marks on the poly using a marking pen.

Snap together the roll-up tube for each side. Using the marks to align each tube, fasten the curtain to the tube with tube clips every 3' per **FIGURE 2** keeping the tube straight.

FIGURE 2

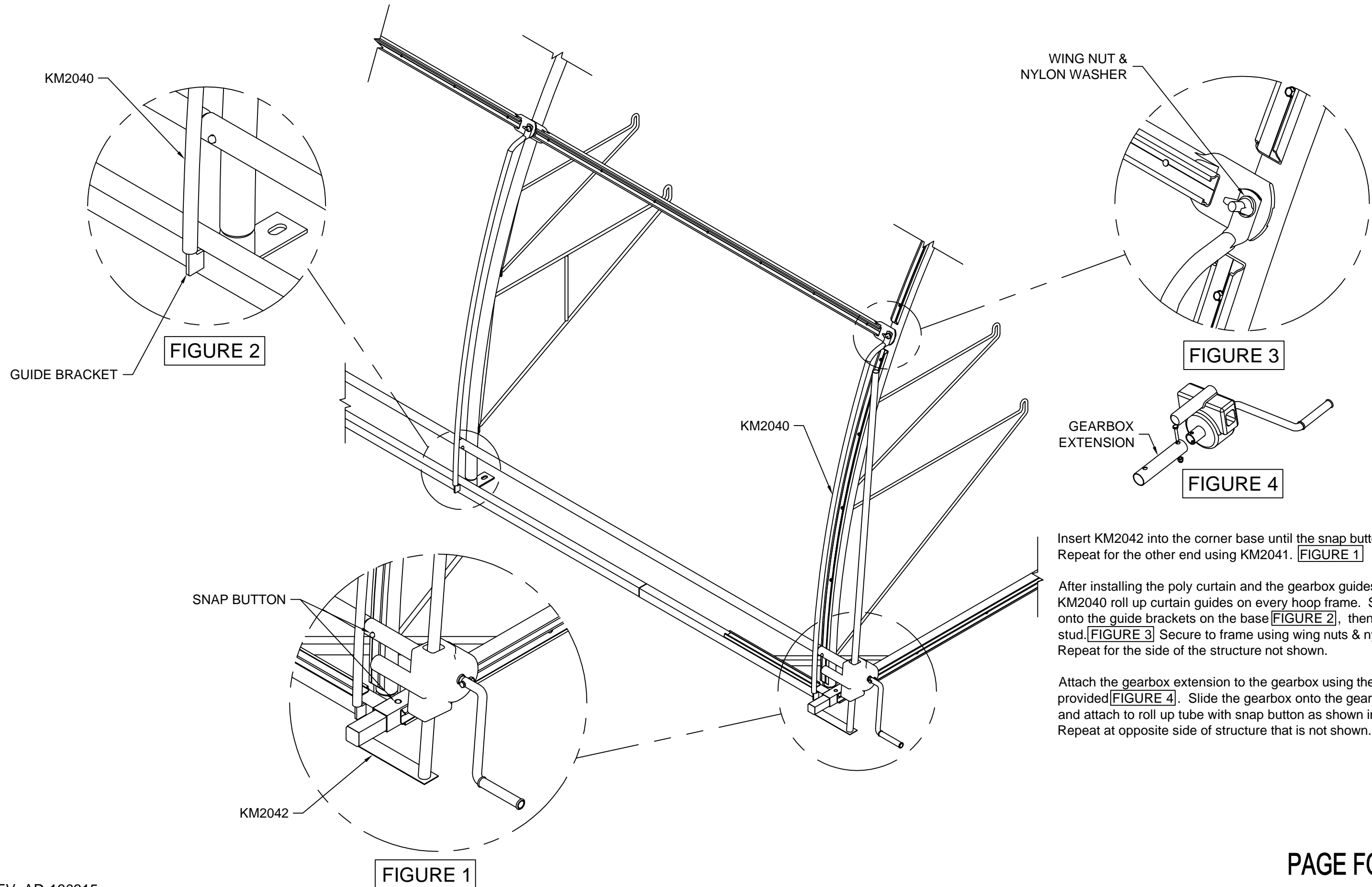

Insert KM2042 into the corner base until the snap button locks. Repeat for the other end using KM2041. **FIGURE 1**

After installing the poly curtain and the gearbox guides attach the KM2040 roll up curtain guides on every hoop frame. Slide guides onto the guide brackets on the base **FIGURE 2**, then onto the stud **FIGURE 3**. Secure to frame using wing nuts & nylon washers. Repeat for the side of the structure not shown.

Attach the gearbox extension to the gearbox using the bolt provided **FIGURE 4**. Slide the gearbox onto the gearbox guide and attach to roll up tube with snap button as shown in **FIGURE 1**. Repeat at opposite side of structure that is not shown.

POLY INSTALLATION

ROOL MART WITH ROLL-UP SIDES

1. With an equal amount of poly on all sides, start installing wiggle wire at the bottom left corner and continue across to the right corner. Be sure to tension poly as you install the wiggle wire.
2. Lift the poly to the top of the end frame and attach one section of wiggle wire centered at the peak. Continue installing wiggle wire down the arch. Be sure to pull the wrinkles out as you go.
3. Finish installing wiggle wire at the door header and the door jamb.

Trim excess poly.

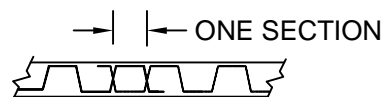
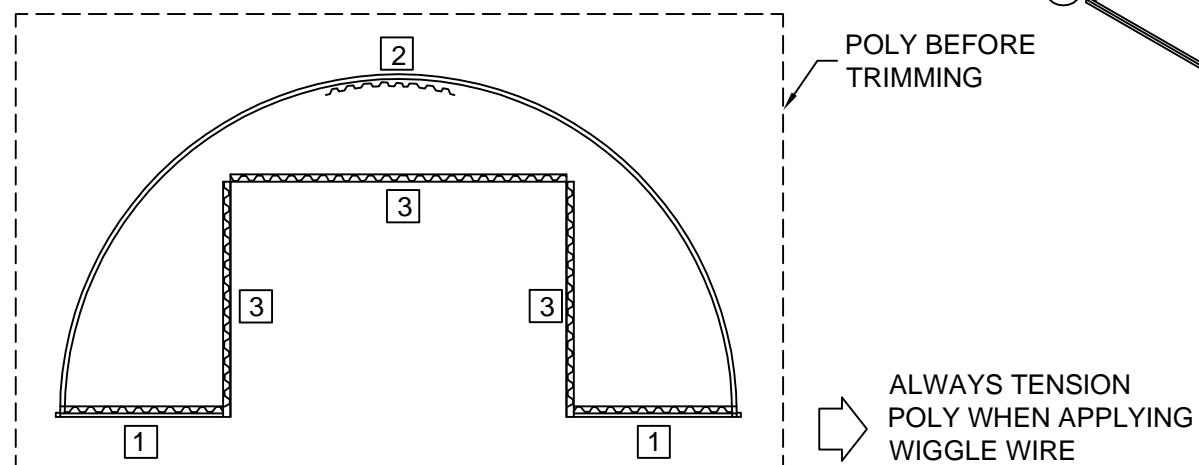

Where wiggle wire ends and a new piece begins, overlap one section to avoid damage to the poly.

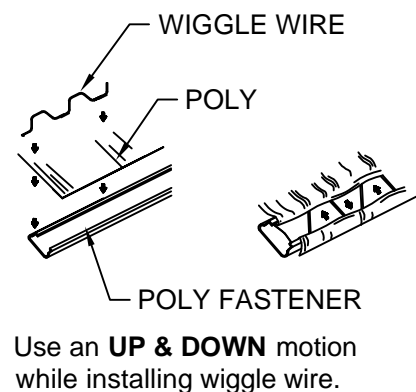

12" WIGGLE WIRE

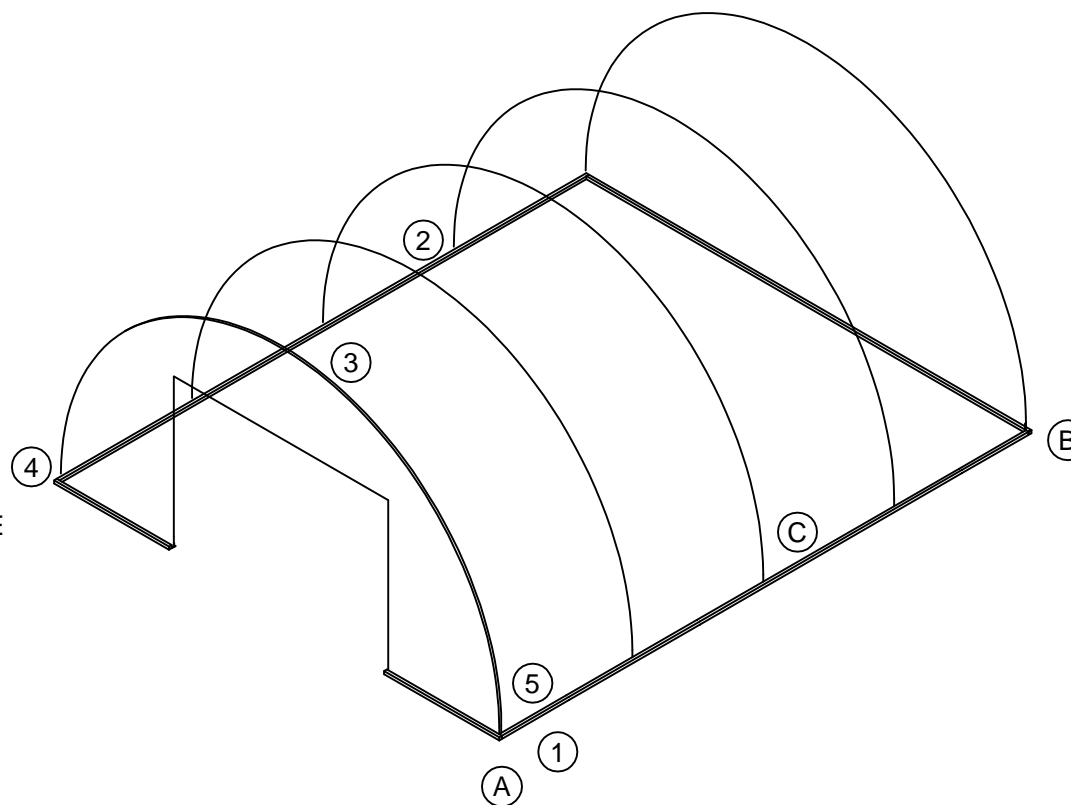
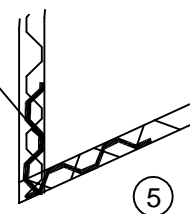

TENSIONED POLY

*POLY DROOP

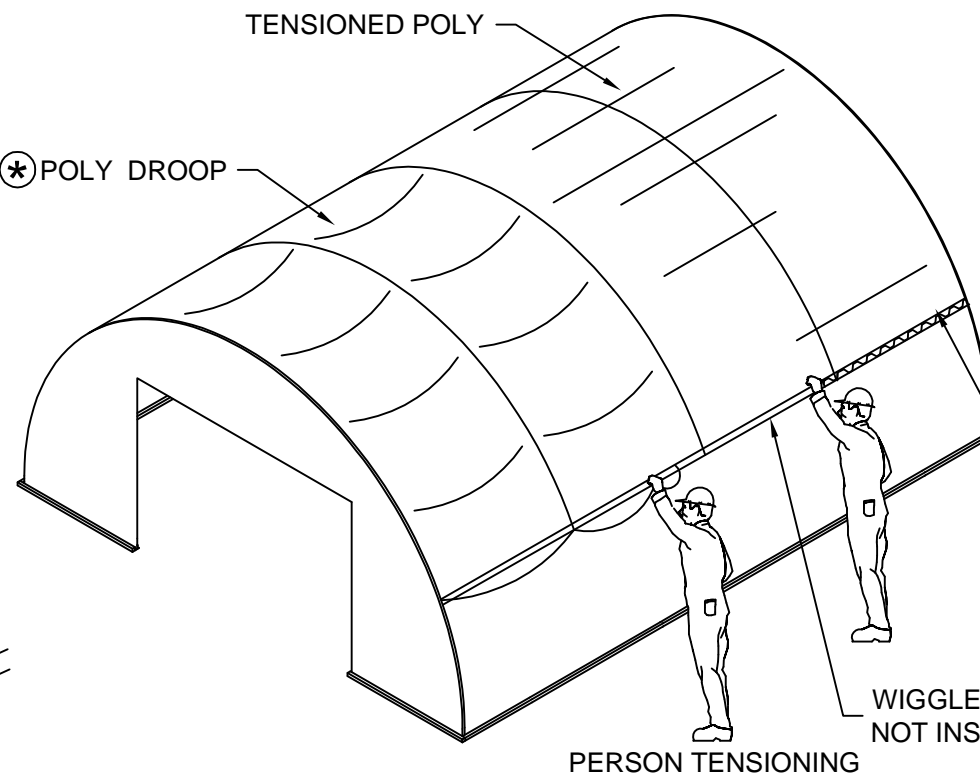

Try to pick a calm day. If it is windy, it's almost impossible to handle the plastic.

Lay out the 6'6" wiggle wire around the perimeter of the structure so they are handy. Unroll the poly on the ground along the length of the structure. Be sure you have equal overhang at both ends of the greenhouse.

Place one worker at point (A) and point (B). It helps to have another worker inside the KOOL-MART at point (C), on a ladder, to help carry the poly over.

Once the poly is in position, begin installing wiggle wire sections at point (1). Complete this side of the greenhouse, using the edge of the poly as a guide. (3" to 6" overhang is adequate)

Go to the other side and install a wiggle wire section at point (2) (center), and fan out from there. Complete this side.

HELPFUL HINT: *To avoid poly drooping between bows, instruct a helper to tension poly one section away from the person installing the wiggle wire. You will notice the wrinkles disappear when this method is used. When the person who is installing the wiggle wire meets the person tensioning the poly, the tensioner can move to the next bow.

After all wiggle wire has been installed, using a blunt object, press all wiggle wire firmly into base to ensure it has been seated properly.

Starting in the center of the end hoop, (3), begin installing wiggle wire sections down to point (4). Go back to point (3), and install wiggle wire sections to point (5). Do this on both end hoops.

After this is done, cut remaining pieces to approximately 12" lengths. Use these in the corners (dotted lines) to reinforce the top cover and end poly. See drawing (5)

NOTE: IF THE POLY IS INSTALLED ON A COOL DAY, IT MAY EXPAND AS THE TEMPERATURE WARMS, CAUSING IT TO DROOP. IT MAY BE NECESSARY TO RETENSION THE SHEET OF PLASTIC AT A LATER DATE.