

# END CAP 3-TIER

EC7032



## Assembly Instructions



### Important!

Please read these instructions carefully before beginning to assemble this display. Save these instructions for future reference.

Revision: AA-140204

# Assembly Instructions

## 1.0 Product Number Cross-Reference

<b>END CAP 3-TIER</b>				
<b>DESCRIPTION</b>	<b>GALVA-NIZED</b>	<b>RED</b>	<b>BLACK</b>	<b>GREEN</b>
END CAP BENCH 36 BASE	PX1018	PR1018	PK1018	PG1018
POST EXTENSION 10"	PX1112	PR1112	PK1112	PG1112
EC POST 2 LEVEL/14.5 OC	PX1111	PR1111	PK1111	PG1111
END CAP MIDDLE BENCH	PX1016	PR1016	PK1016	PG1016
END CAP TOP BENCH	PX1014	PR1014	PK1014	PG1014
SOCKET SET SCREW 5/16"x 1/2"	NB1978			
WRENCH HEX 5/32" LONG	NB1979			
SNAPPER PIN.250"x2.25"	NB1996			
1 1/4" SQ BLK PLUG	RS5001			









<b>OPTIONAL PARTS</b>	
<b>OPTIONAL CASTERS</b>	
5" CASTER/EXP 1-1/4" W/BRAKE	FB2513
<b>END CAP CONNECTION KIT</b>	
HEX BOLT 5/16"x2 1/2" ZP G5	NB1850
LOCK WASHER 5/16	NB1862
HEX NUT 5/16" ZP	NB1872

- Part number references are included in the instructions for the galvanized components. Refer to the second letter change in the part number for cross reference to the appropriate powder-coated color.

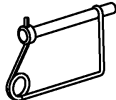

## Assembly Instructions

### 2.0 Parts List

#### 2.1 Base Unit

IMAGE	TAG #	QTY	ITEM #	DESCRIPTION
	1	1	PX1018	END CAP BENCH 36 BASE
	2	3	PX1112	POST EXTENSION 10"
	3	1	PX1111	EC POST 2 LEVEL/14.5 OC
	4	4	RS5001	1 1/4 SQ BLK PLUG
	5	2	NB1996	SNAPPER PIN.250"x2.25"
	6	4	NB1978	SOCKET SET SCREW 5/16"x1/2"
	7	1	PX1016	END CAP MIDDLE BENCH
	8	1	NB1979	WRENCH HEX 5/32" LONG
	9	1	PX1014	END CAP TOP BENCH

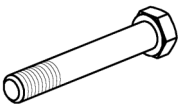
#### 2.2 Optional Components

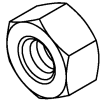
IMAGE	TAG #	QTY	ITEM #	DESCRIPTION
	10	3	FB2513	5" CASTER/EXP 1-1/4" W/BRAKE
	11	5	NB1850	HEX BOLT 5/16"x2 1/2" ZP G5
	12	5	NB1862	LOCK WASHER 5/16
	13	5	NB1872	HEX NUT 5/16" ZP

Questions? Please call Poly-Tex, Inc. • PO Box 458, 27725 Danville Ave, Castle Rock, MN 55010 • (800) 852-3443 • (651)463-7009 • Fax (651) 463-7279 • [www.poly-tex.com](http://www.poly-tex.com)

# Assembly Instructions

## 3.0 Base Unit

### 3.1 Base & Support

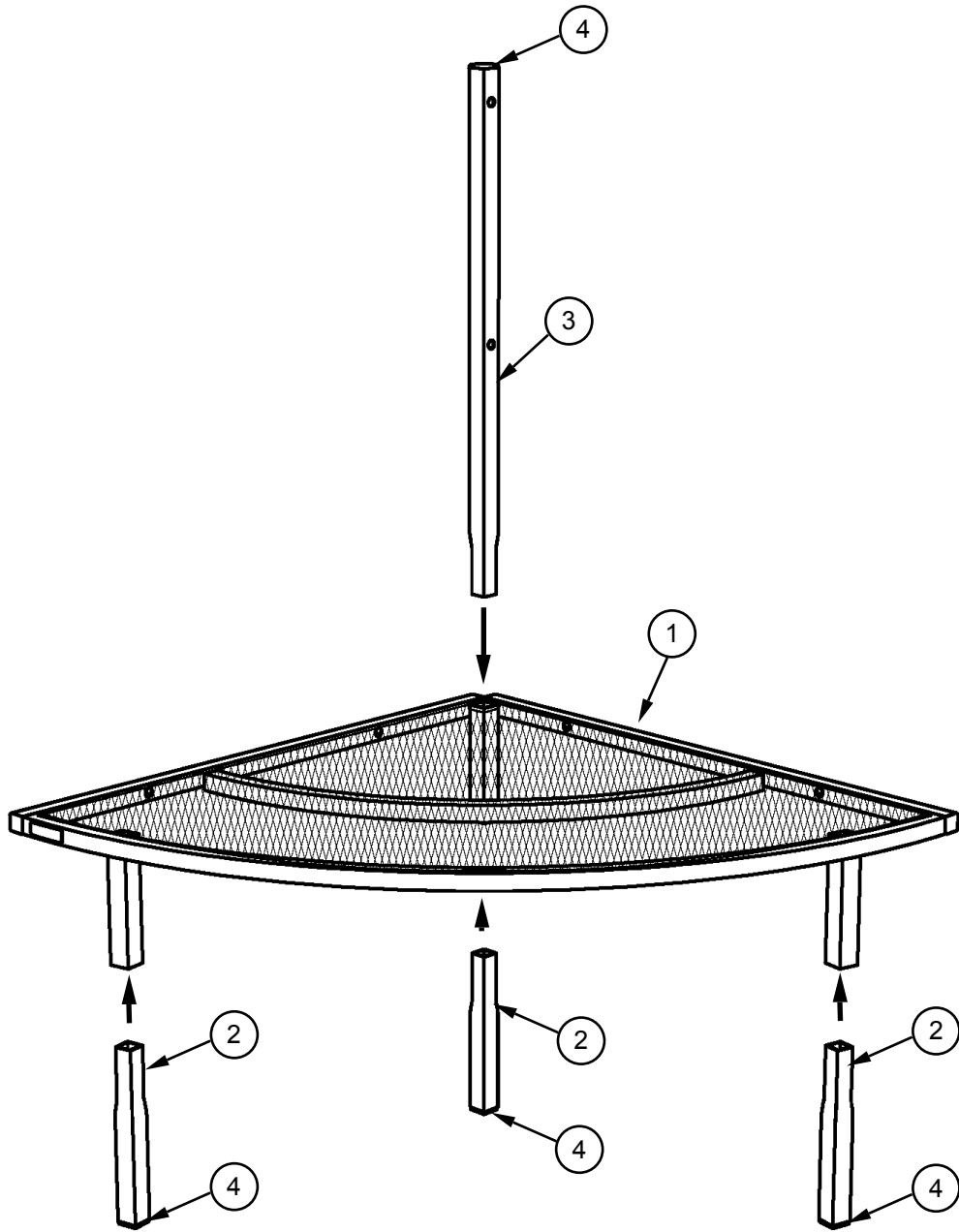

TAG #	QTY	ITEM #	DESCRIPTION
1	1	PX1018	END CAP BENCH 36 BASE
2	3	PX1112	POST EXTENSION 10"
3	1	PX1111	EC POST 2 LEVEL/14.5 OC
4	4	RS5001	1 1/4" SQ BLK PLUG

- If Casters are provided with this assembly, install them at this time according to step 4.1.
- Install three Post Extensions PX1112 into bottom legs of End Cap Bench PX1018 (mallet or hammer may be required for levelling).
- Place End Cap Bench PX1018 upright. Insert EC Post PX1111 with Plug RS5001 into back of Bench as shown.

# Assembly Instructions

## 3.2 Middle Bench

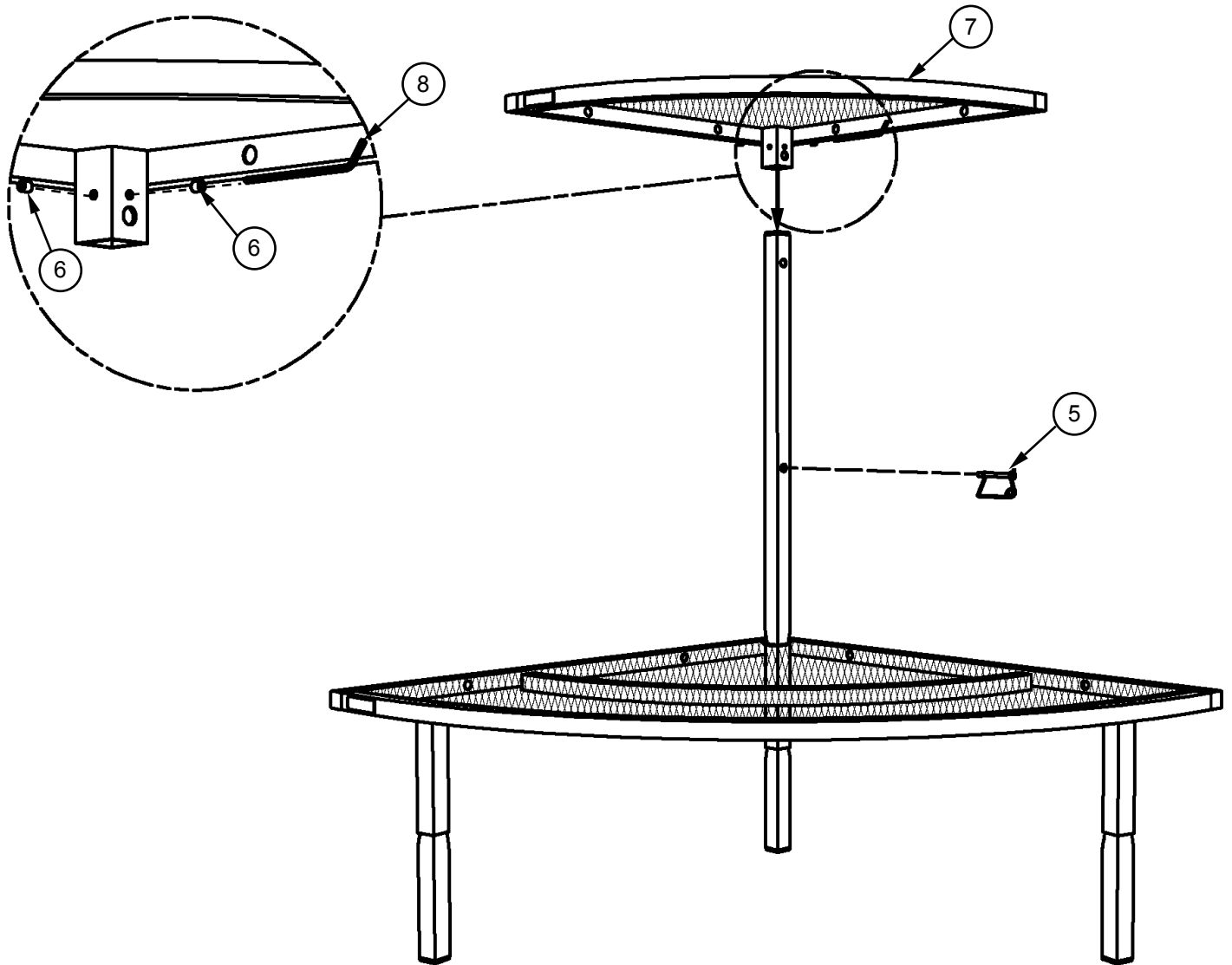

TAG #	QTY	ITEM #	DESCRIPTION
5	1	NB1996	SNAPPER PIN .250" x 2.25"
6	2	NB1978	SOCKET SET SCREW 5/16" x 1/2"
7	1	PX1016	END CAP MIDDLE BENCH
8	1	NB1979	WRENCH HEX 5/32" LONG

- Install Snapper Pin NB1996 in post to establish bench elevation. Loosely insert Socket Head Set Screws NB1978 into Middle Bench PX1016.
- Position the Top Bench PX1016 over the Post and lower the Bench until it rests on the Snapper Pin. Remove Pin and re-install with holes in Bench and Post aligned.
- Tighten Socket Set Screws with Hex Wrench NB1979 until snug.

## Assembly Instructions

### 3.3 Top Bench

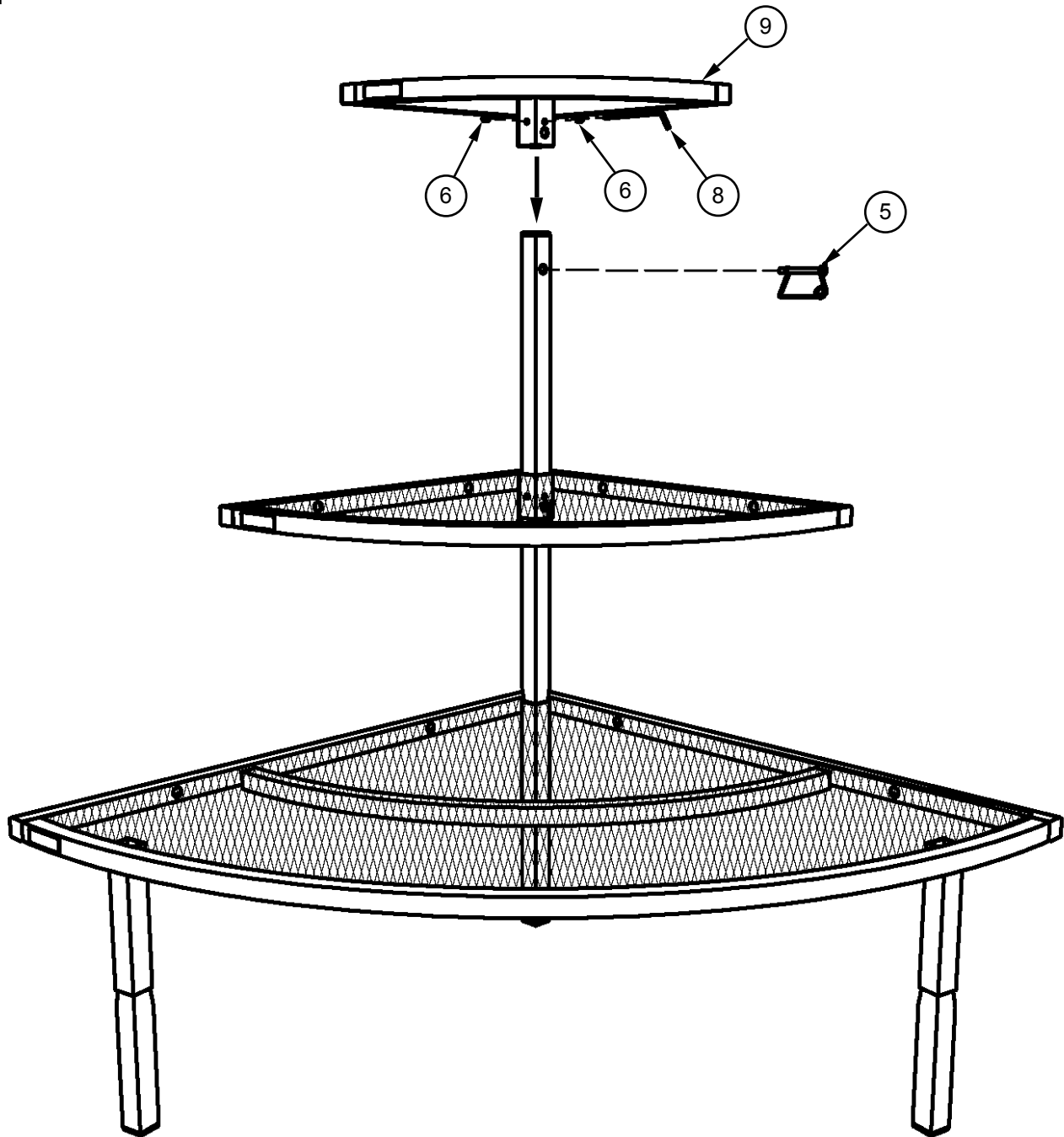

TAG #	QTY	ITEM #	DESCRIPTION
5	1	NB1996	SNAPPER PIN .250"x2.25"
6	2	NB1778	SOCKET SET SCREW 5/16"x1/2"
8	1	NB1979	WRENCH HEX 5/32" LONG
9	1	PX1014	END CAP TOP BENCH

- Install Snapper Pin NB1996 in post to establish bench elevation. Loosely insert Socket Head Set Screws NB1978 into Top Bench PX1014.
- Engage the Top Bench on the Post with the Snapper Pin NB1996.
- Tighten Socket Set Screws with Hex Wrench NB1979 until snug.

# Assembly Instructions

## 4.0 Mobility Casters

### 4.1 Casters

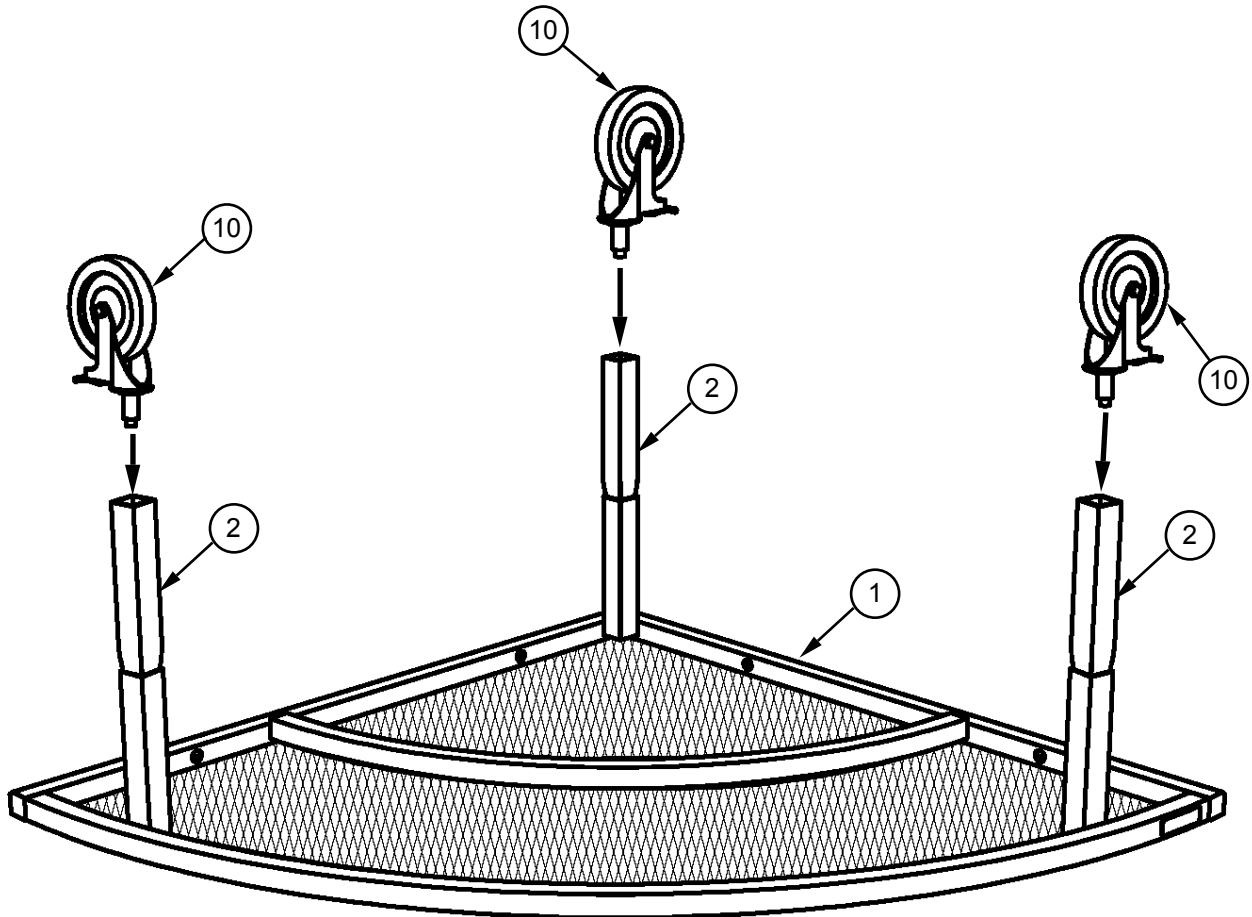

TAG #	QTY	ITEM #	DESCRIPTION
1	1	PX1018	END CAP BENCH 36 BASE
2	3	PX1112	POST EXTENSION 10"
10	3	FB2513	5" CASTER/EXP 1-1/4" W/BRAKE

- Prior to assembly of Display, position the End Cap Bench Base with the legs up.
- Insert a Caster FB2513 stem fully into each Post Extension and rotate the collar of each Caster until it fits firmly in place.
- Return the End Cap Bench upright and lock the casters to maintain position.

# Assembly Instructions

## 5.0 Connecting Run

### 5.1 Connection Extension

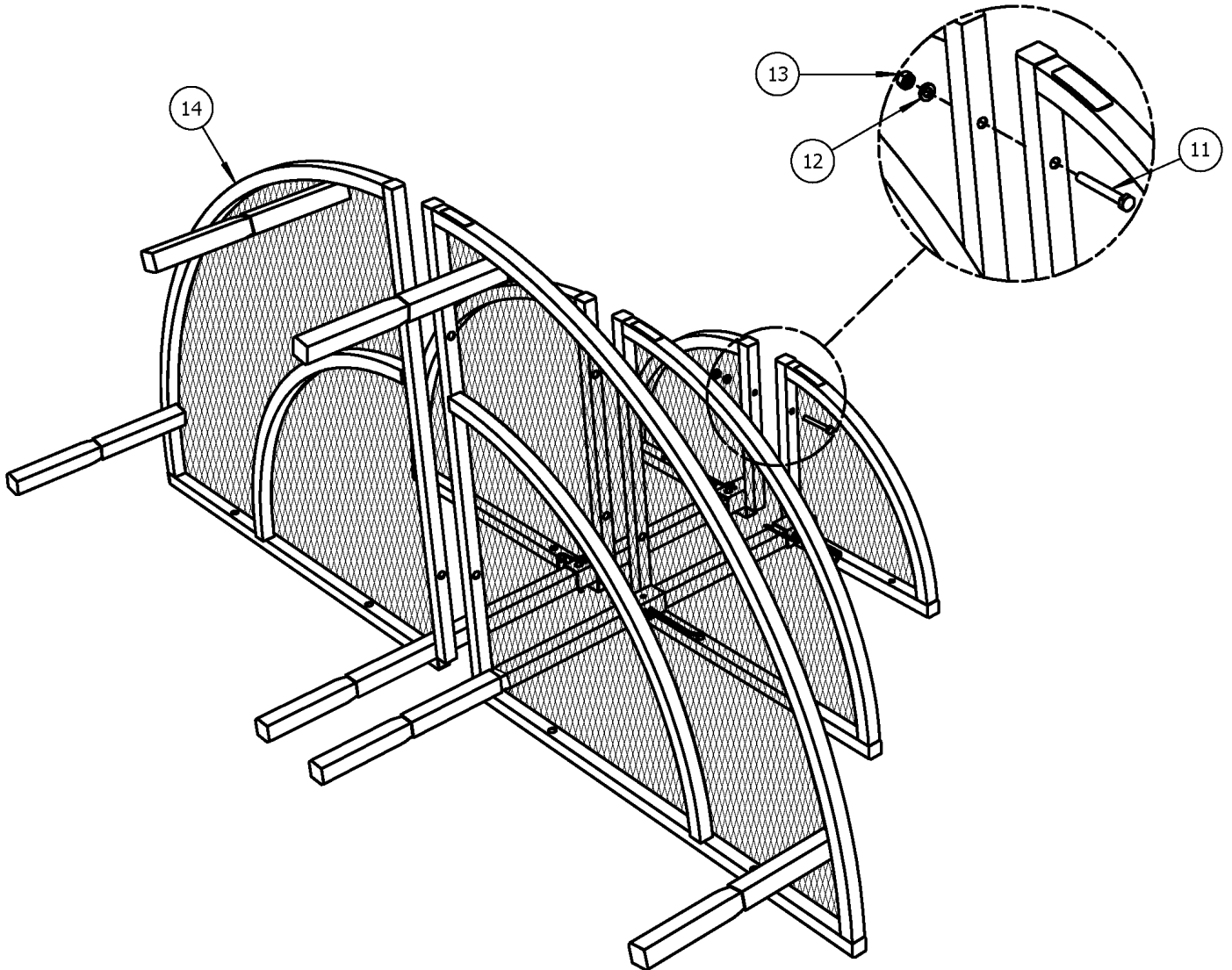

TAG #	QTY	ITEM #	DESCRIPTION
11	5	NB1850	HEX BOLT 5/16"X2 1/2" ZP G5
12	5	NB1862	LOCK WASHER 5/16
13	5	NB1872	HEX NUT 5/16" ZP
14	1	EC7032	END CAP TRI-STEP

- Assemblies can be bolted together to form a circular or partial circle as shown using parts from the End Cap Connection Kit. Use two wrenches and insure that bolts, washers and nuts are tight (5 places).
- NOTE: Connected runs of this product are not intended to be used on Casters.

## Assembly Instructions

# SAFETY GUIDELINES

Do not climb, sit on or use this product as a ladder. Injuries may occur.

Do not place or install electrical items on this product. Wet conditions are typical and electrical shock may occur.

Do not place this product on a slope that exceeds 3 degrees.

Do not move this display after product is in place. Damage to the display and injuries may occur.

# CARE & MAINTENANCE

To remove loose soil and debris, simply spray the soiled areas with water from a garden hose.

Prior to storage, all surfaces of this product should be sprayed down with water and allowed to dry completely.

## Limited Warranty

Poly-Tex Inc. warrants its products to be free from defects in material and workmanship for a period of (1) year from date of invoice. This warranty is provided to the original purchaser of the product and is not transferable. Poly-Tex does not warrant parts not manufactured by Poly-Tex, but does assign any transferable manufacturer or supplier warranties. Should any defect be found, full repair or replacement will be rendered to the customer at no cost following inspection by a Poly-Tex representative and the return of the defective product to our Castle Rock, MN factory. Expenses for removal or reinstallation of defective products will not be covered by the warranty.

**POLY-TEX SHALL NOT BE HELD RESPONSIBLE FOR ANY SPECIAL OR CONSEQUENTIAL DAMAGES, OR FOR ANY DELAY IN PERFORMANCE OF THIS WARRANTY BEYOND OUR CONTROL. THIS WARRANTY IS EXCLUSIVE AND IN LIEU OF ALL OTHER WARRANTIES WHETHER IMPLIED, WRITTEN OR ORAL INCLUDING THE WARRANTIES OF MERCHANTABILITY AND FITNESS FOR A PARTICULAR PURPOSE.**

This warranty does not cover damage from customer abuse, misuse, improper installation, customer modifications, customer negligence in performing normal maintenance, damage resulting from acts of nature.

Contact information:  
Poly-Tex, Inc. PO Box 458  
27725 Danville Ave Castle Rock, MN 55010  
Toll free (800) 852-3443 Fax (651) 463-2479  
[www.poly-tex.com](http://www.poly-tex.com)