

END CAP BENCH DISPLAY

EC7006



Assembly Instructions



Important!

Please read these instructions carefully before beginning to assemble this display. Save these instructions for future reference.

Revision: AA-140307

Assembly Instructions

1.0 Product Number Cross-Reference

END CAP BENCH DISPLAY				
DESCRIPTION	GALVANIZED	RED	BLACK	GREEN
END CAP BENCH 36 BASE	PX1018	PR1018	PK1018	PG1018
END CAP 2 SWAGE RISER	PX1113	PR1113	PK1113	PG1113
1 1/4" SQ BLK PLUG	RS5001			



OPTIONAL PARTS	
OPTIONAL CASTERS	
5" CASTER/EXP 1-1/4" W/BRAKE	FB2513
END CAP CONNECTION KIT	
HEX BOLT 5/16"X2 1/2" ZP G5	NB1850
LOCK WASHER 5/16	NB1862
HEX NUT 5/16" ZP	NB1872

- Part number references are included in the instructions for the galvanized components. Refer to the second letter change in the part number for cross reference to the appropriate powder-coated color.



Assembly Instructions

2.0 Parts List

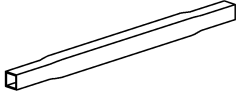
2.1 Base Unit

IMAGE	TAG #	QTY	ITEM #	DESCRIPTION
	1	2	PX1018	END CAP BENCH 36 BASE
	2	6	RS5001	1 1/4 SQ BLK PLUG
	3	3	PX1113	END CAP 2 SWAGE RISER

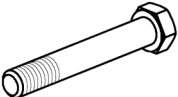
2.2 Optional Components

IMAGE	TAG #	QTY	ITEM #	DESCRIPTION
	4	3	FB2513	5" CASTER/EXP 1-1/4" W/BRAKE
	5	4	NB1850	HEX BOLT 5/16"X2 1/2" ZP G5
	6	4	NB1862	LOCK WASHER 5/16
	7	4	NB1872	HEX NUT 5/16" ZP

Assembly Instructions

3.0 Base Unit

3.1 Base & Support

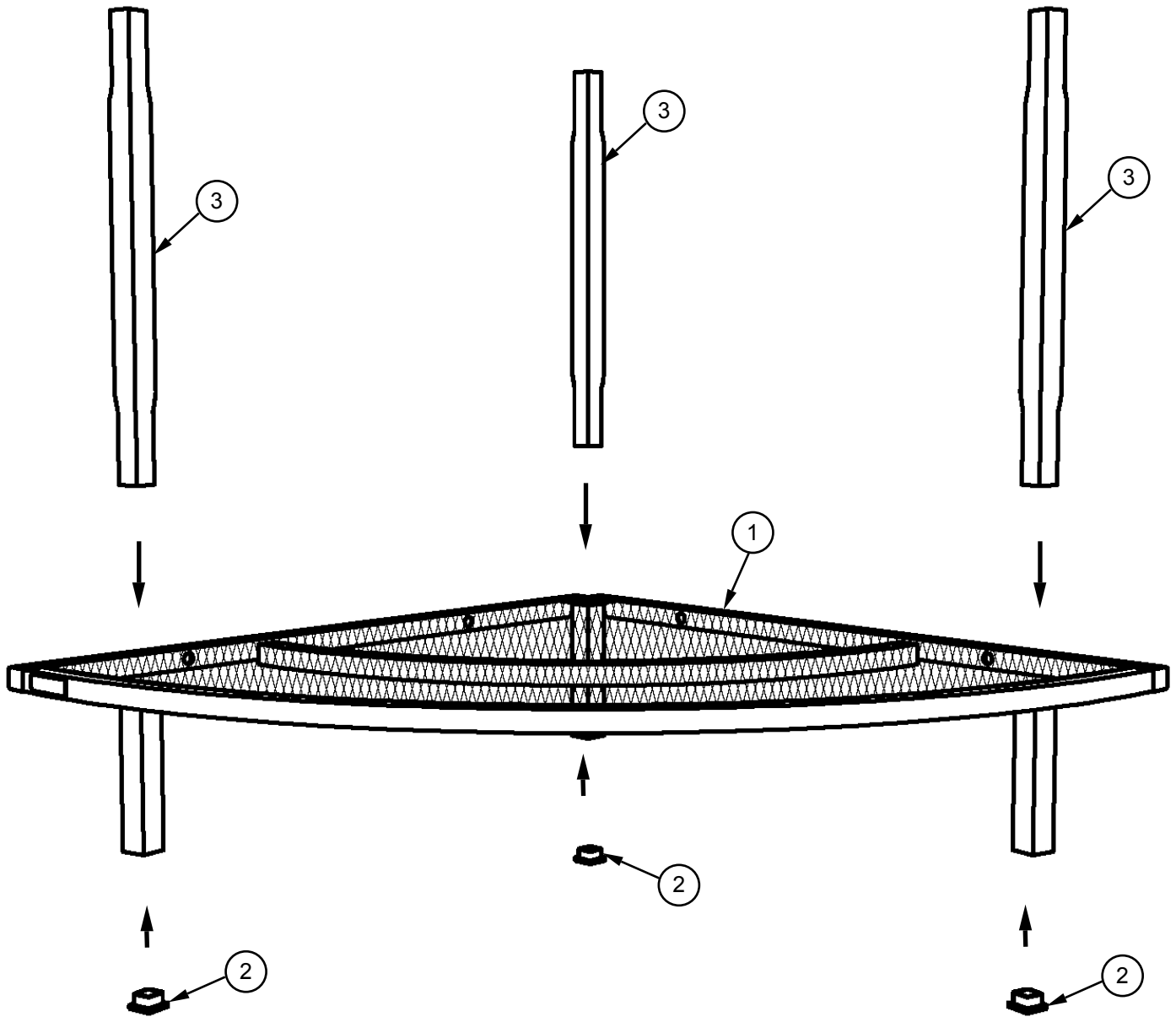

TAG #	QTY	ITEM #	DESCRIPTION
1	1	PX1018	END CAP BENCH 36 BASE
2	3	RS5001	1 1/4 SQ BLK PLUG
3	3	PX1113	END CAP 2 SWAGE RISER

- If Casters are provided with this assembly, install them at this time according to step 4.1.
- Install three Black Plugs RS5001 into bottom legs of End Cap Bench PX1018 (mallet or hammer may be required).
- Place End Cap Bench PX1018 upright. Insert Post Extensions PX1113 into Bench as shown.

Assembly Instructions

3.3 Top Bench

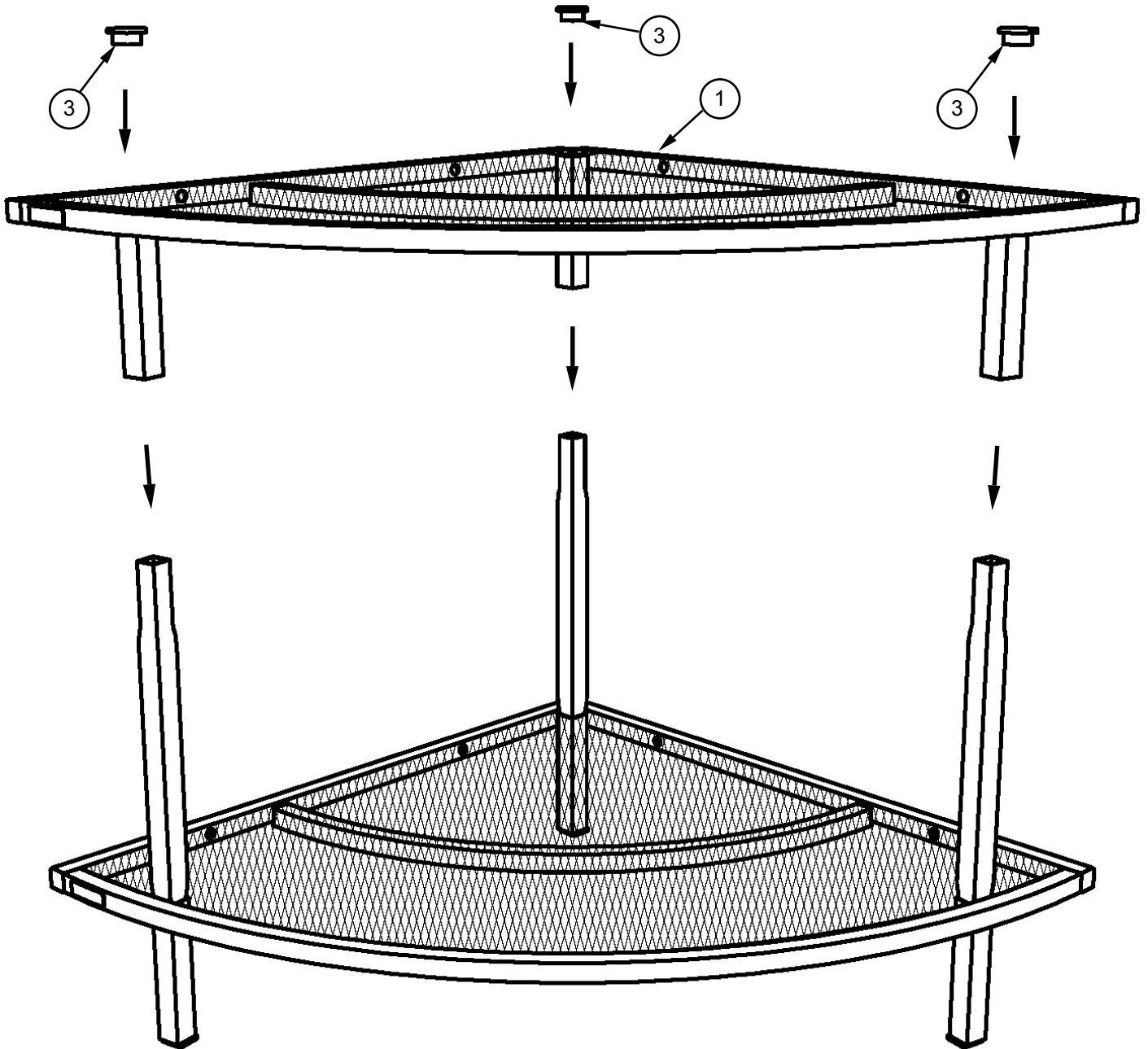

TAG #	QTY	ITEM #	DESCRIPTION
1	1	PX1018	END CAP BENCH 36 BASE
3	3	RS5001	1 1/4" SQ BLK PLUG

- Position the Top Bench PX1018 over the Posts and lower the Bench until it rests on the Risers.
- Install three Black Plugs RS5001 into top holes of Bench (mallet or hammer may be required for both operations).

Assembly Instructions

4.0 Mobility Casters

4.1 Casters

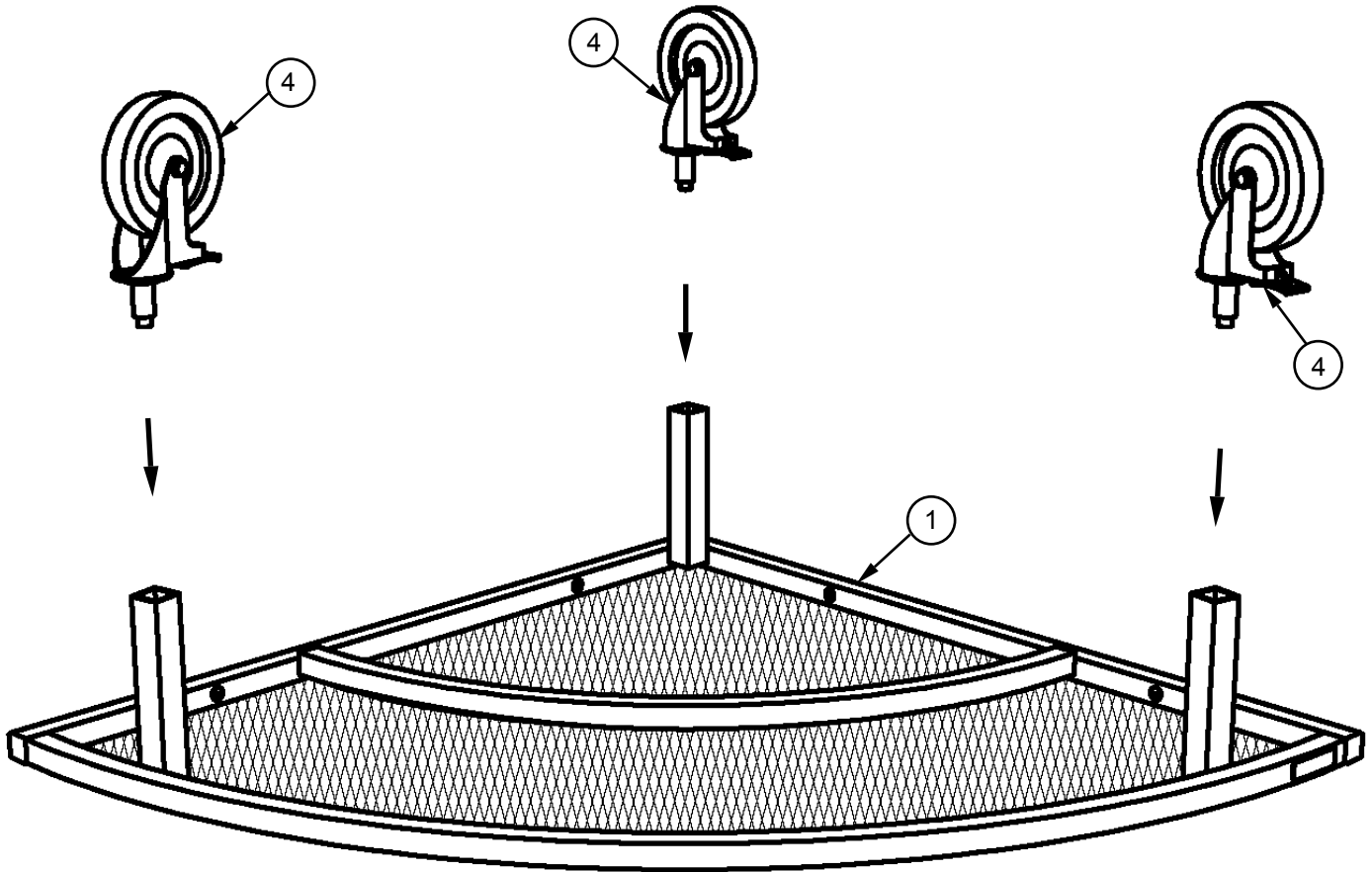

TAG #	QTY	ITEM #	DESCRIPTION
1	1	PX1018	END CAP BENCH 36 BASE
4	3	FB2513	5" CASTER/EXP 1-1/4" W/BRAKE

- Prior to assembly of Display, position the End Cap Bench Base with the legs up.
- Insert a Caster FB2513 stem fully into each Post Extension and rotate the collar of each Caster until it fits firmly in place.
- Return the End Cap Bench upright and lock the casters to maintain position.

Assembly Instructions

5.0 Connecting Run

5.1 Connection Extension

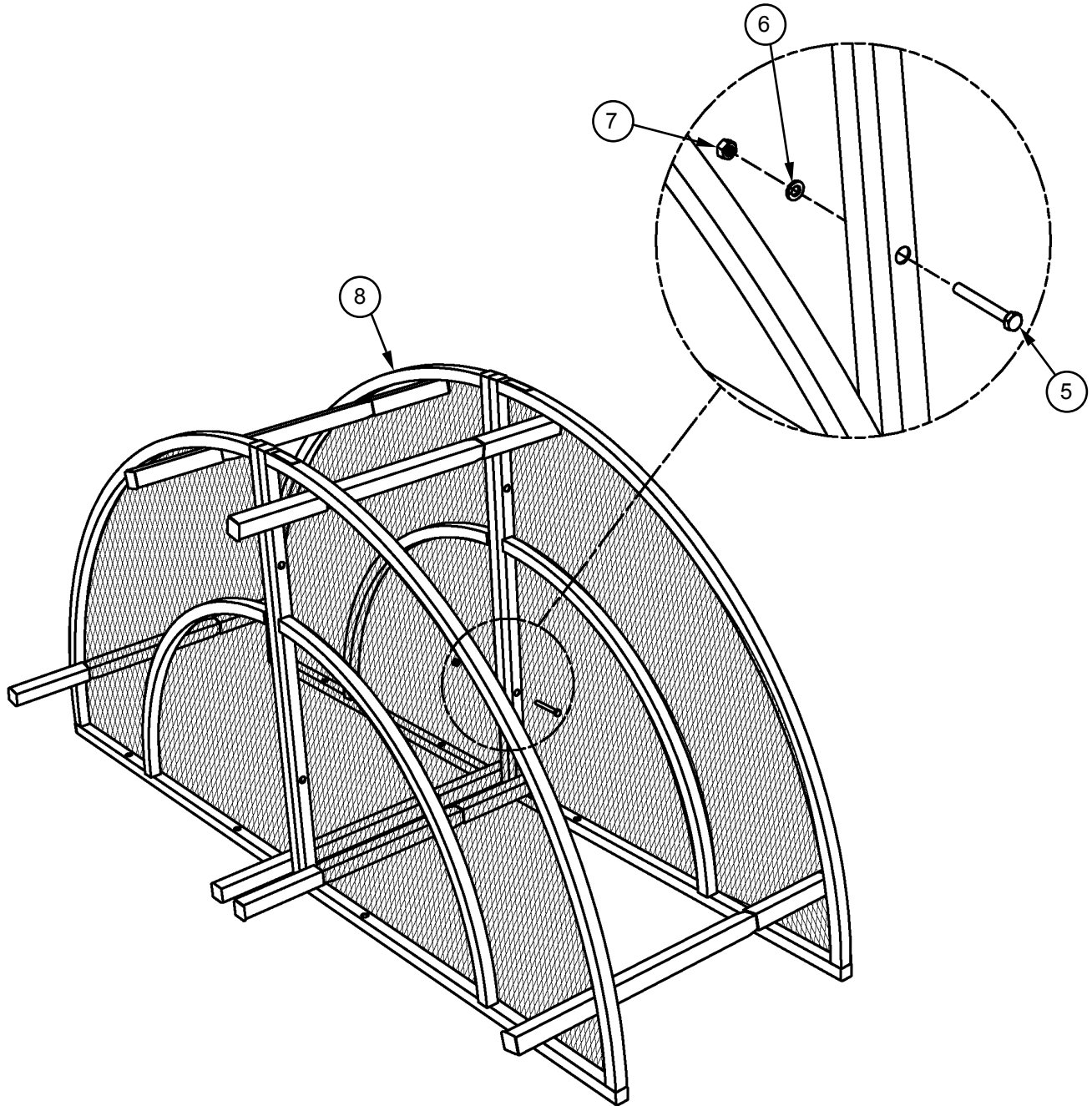

TAG #	QTY	ITEM #	DESCRIPTION
5	4	NB1850	HEX BOLT 5/16"X2 1/2" ZP G5
6	4	NB1862	LOCK WASHER 5/16
7	4	NB1872	HEX NUT 5/16" ZP
8	1	EC7001	END CAP FOASB DISPLAY

- Assemblies can be bolted together to form a circular or partial circle using parts from the End Cap Connection Kit as shown. Use two wrenches and insure that bolts, washers and nuts are tight (3 places).
- NOTE: Connected runs of this product are not intended to be used on Casters.

Assembly Instructions

SAFETY GUIDELINES

Do not climb, sit on or use this product as a ladder. Injuries may occur.

Do not place or install electrical items on this product. Wet conditions are typical and electrical shock may occur.

Do not place this product on a slope that exceeds 3 degrees.

Do not move this display after product is in place. Damage to the display and injuries may occur.

CARE & MAINTENANCE

To remove loose soil and debris, simply spray the soiled areas with water from a garden hose.

Prior to storage, all surfaces of this product should be sprayed down with water and allowed to dry completely.

Limited Warranty

Poly-Tex Inc. warrants its products to be free from defects in material and workmanship for a period of (1) year from date of invoice. This warranty is provided to the original purchaser of the product and is not transferable. Poly-Tex does not warrant parts not manufactured by Poly-Tex, but does assign any transferable manufacturer or supplier warranties. Should any defect be found, full repair or replacement will be rendered to the customer at no cost following inspection by a Poly-Tex representative and the return of the defective product to our Castle Rock, MN factory. Expenses for removal or reinstallation of defective products will not be covered by the warranty.

POLY-TEX SHALL NOT BE HELD RESPONSIBLE FOR ANY SPECIAL OR CONSEQUENTIAL DAMAGES, OR FOR ANY DELAY IN PERFORMANCE OF THIS WARRANTY BEYOND OUR CONTROL. THIS WARRANTY IS EXCLUSIVE AND IN LIEU OF ALL OTHER WARRANTIES WHETHER IMPLIED, WRITTEN OR ORAL INCLUDING THE WARRANTIES OF MERCHANTABILITY AND FITNESS FOR A PARTICULAR PURPOSE.

This warranty does not cover damage from customer abuse, misuse, improper installation, customer modifications, customer negligence in performing normal maintenance, damage resulting from acts of nature.

Contact information:
Poly-Tex, Inc. PO Box 458
27725 Danville Ave Castle Rock, MN 55010
Toll free (800) 852-3443 Fax (651) 463-2479
www.poly-tex.com