

BM1000 fruit and floral peddler

ASSEMBLY INSTRUCTIONS



IMPORTANT

Please read these instructions carefully before you start to assemble this display. Save these instructions for future reference.

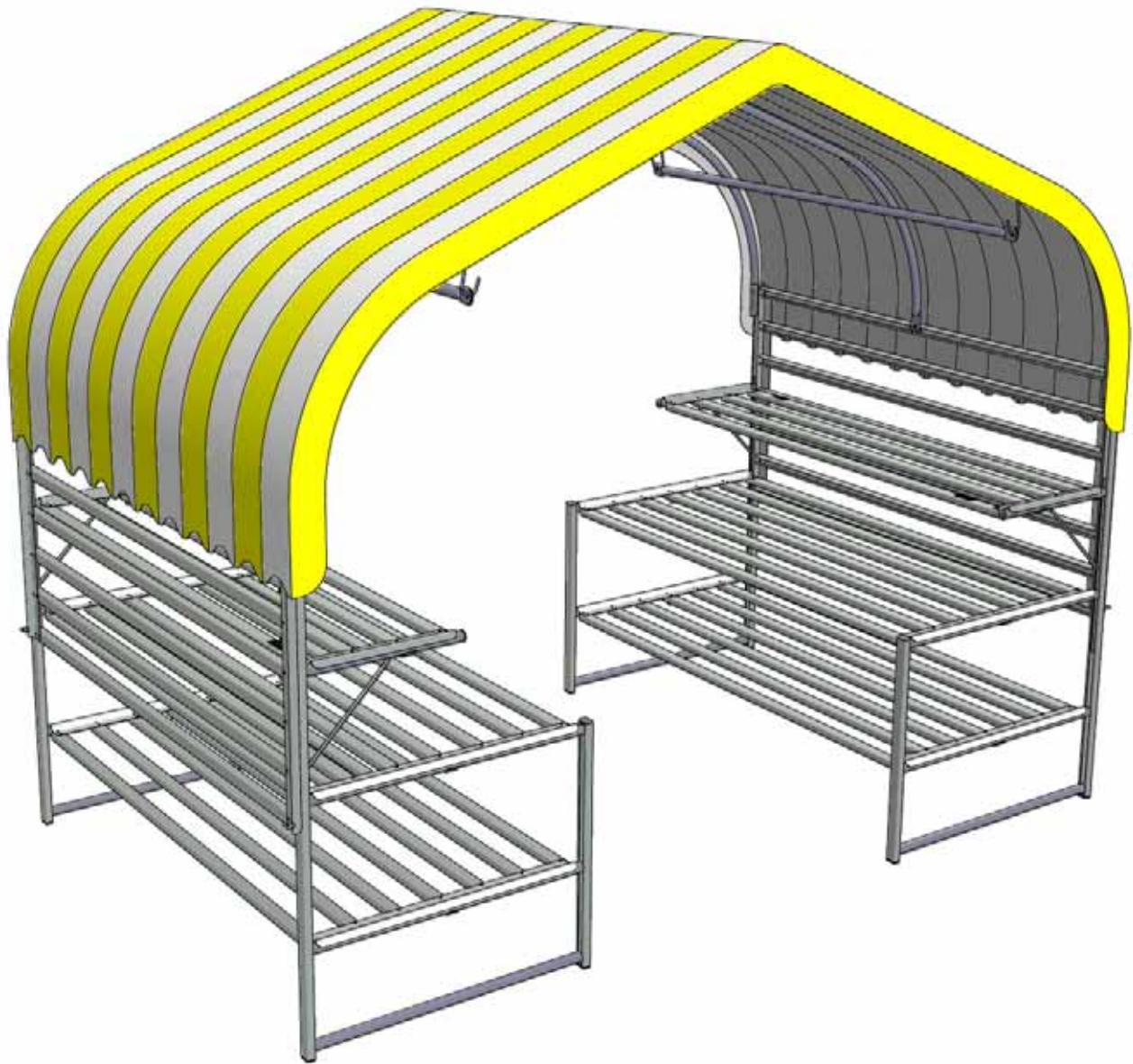

PARTS IDENTIFICATION

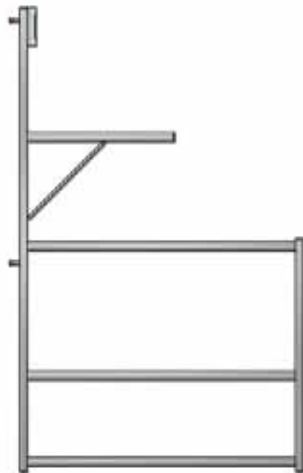

BENCH END
(FB2016)
qty (4)



3' x 6' FENCE
(FB2008)
qty (2)

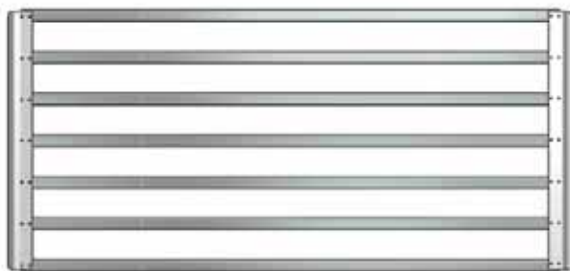

3' x 6' BENCH TOP
(FB2552)
qty (4)



1'-6" x 6' BENCH TOP
(FB2554)
qty (2)



BALL KNOB
(NB1927)
qty (4)



NORSTAD CLIP
(FT3600)
qty (12)



THUMB SCREW
(NB1924)
qty (12)

TOOLS & EQUIPMENT REQUIRED

PARTS IDENTIFICATION



INTERMEDIATE HOOP
(BM5031)
qty (4)



CENTER HOOP
(BM5032)
qty (2)



RIDGE PURLIN
(BM5044)
qty (1)



BASKET PURLIN
(GM4000)
qty (2)



STOP TAB
(FT2570)
qty (2)

6" BASKET
PURLIN HOOK
(BM5045)
qty (4)

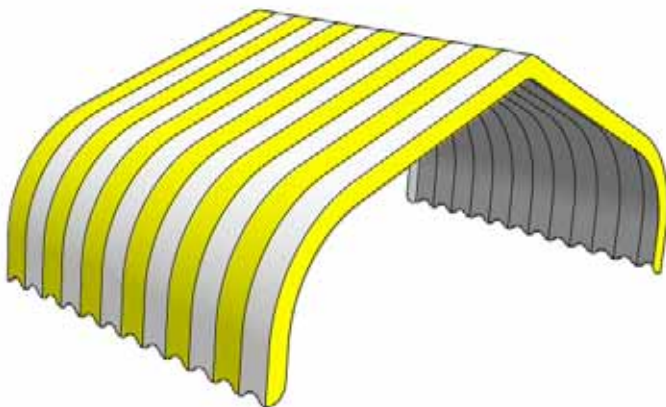

CANOPY
qty (1)

ASSEMBLY INSTRUCTIONS

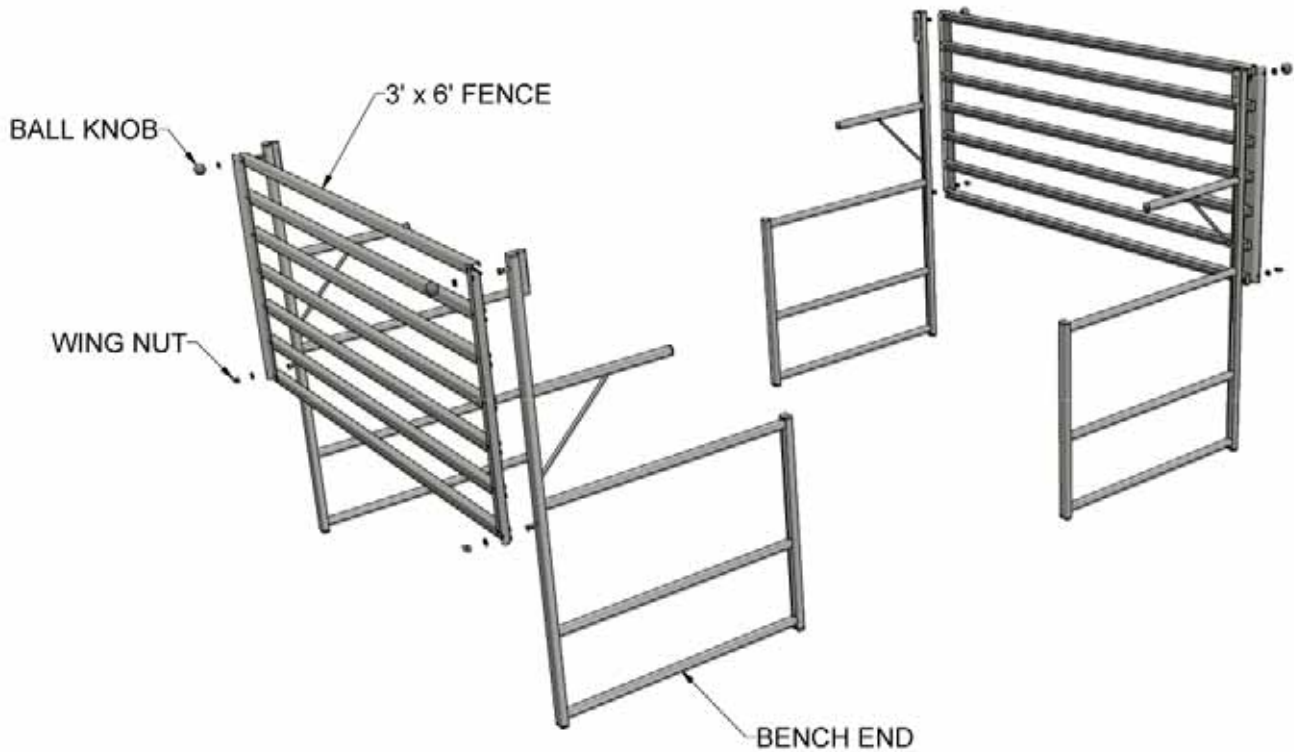

INSTRUCTIONS:

1. ATTACH FENCES TO BENCH ENDS USING NYLON WASHERS AND WING NUTS ON THE LOWER STUDS AND NYLON WASHERS AND BALL KNOBS ON THE UPPER STUDS.
2. PLACE BENCH TOPS ON BENCH ENDS AND SECURE WITH NORSTAD CLIPS AND THUMB SCREWS. USE ONE NORSTAD CLIP AND THUMBSCREW ON EACH END OF EACH BENCH TOP.

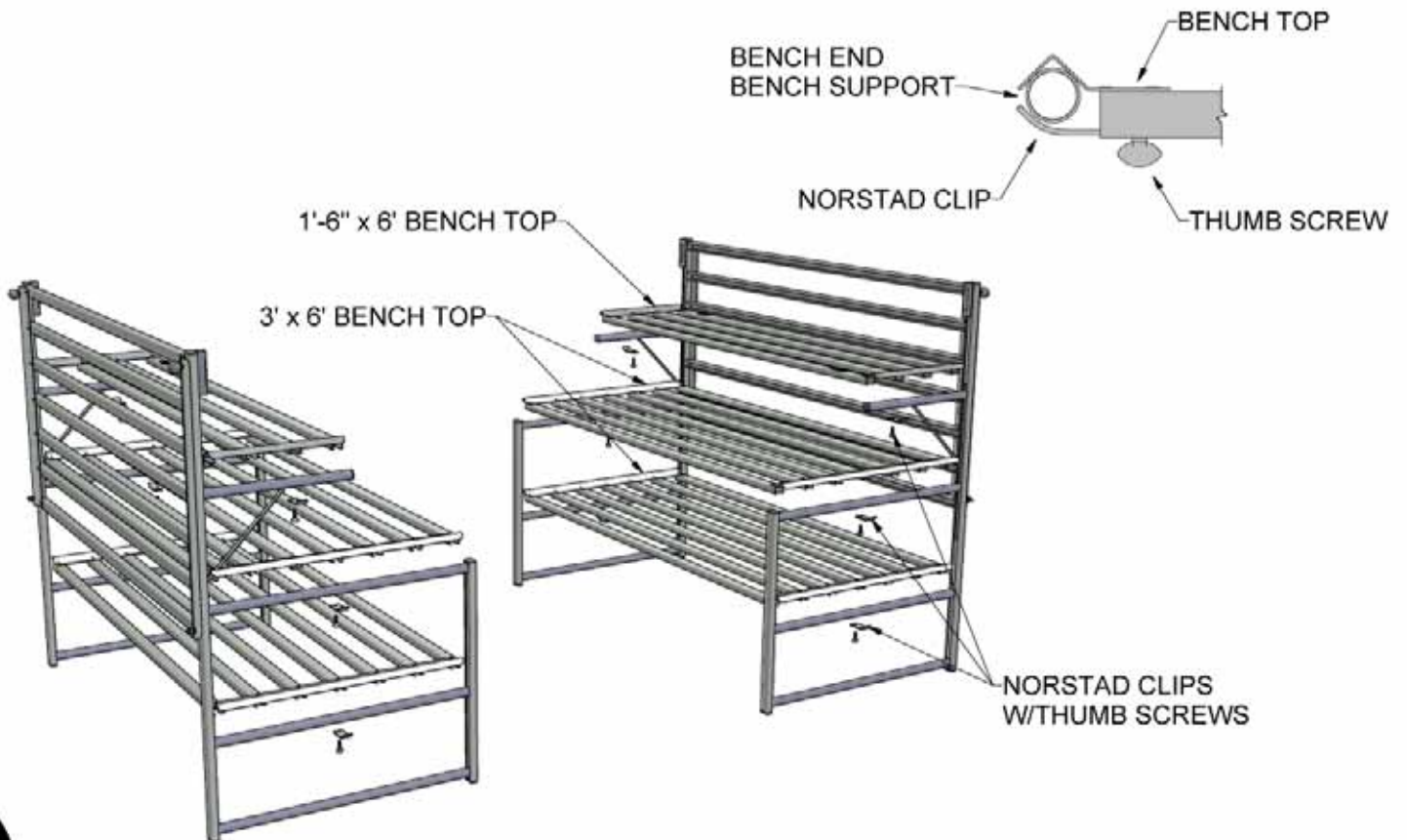

ASSEMBLY INSTRUCTIONS

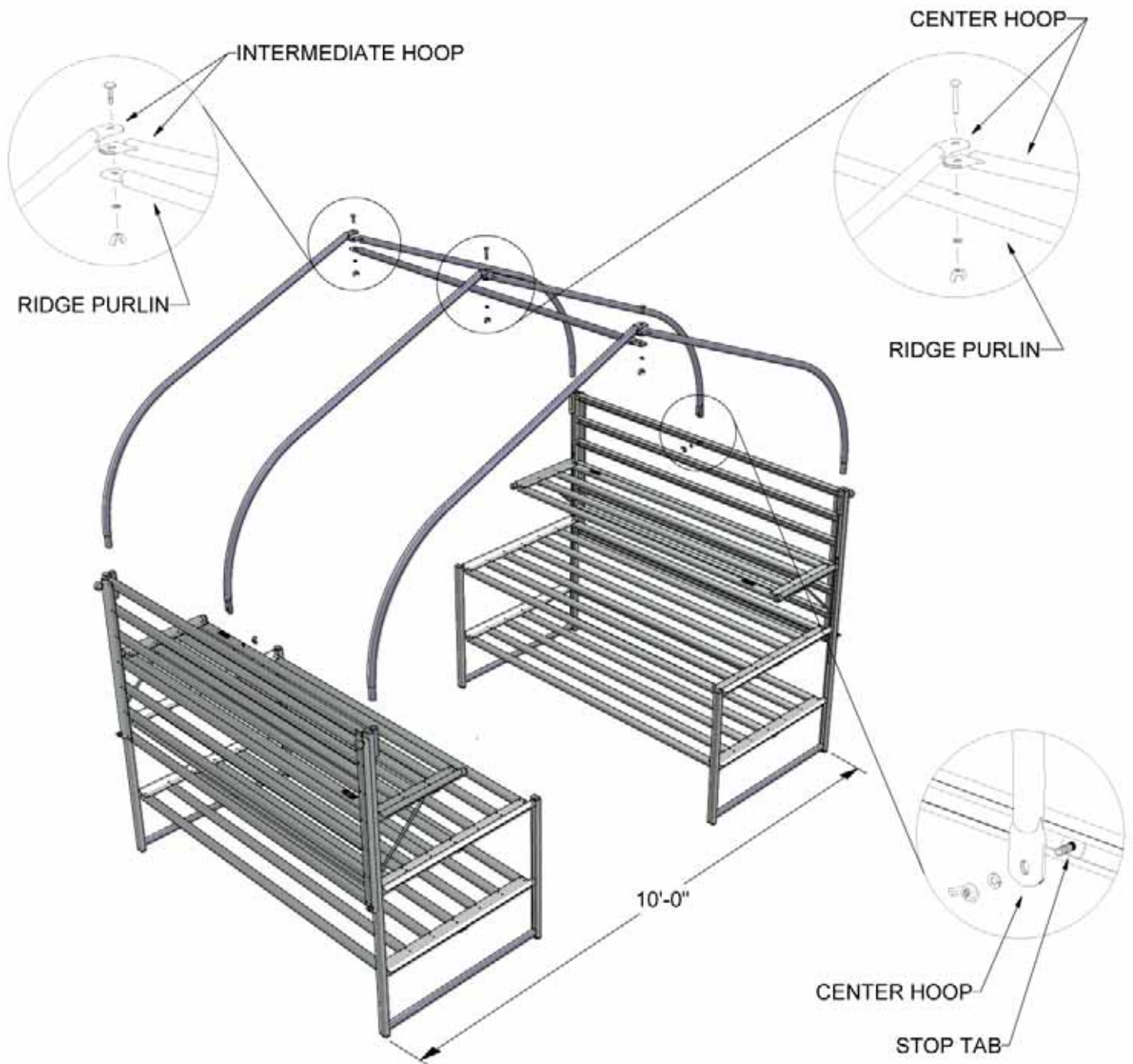

3. INSERT INTERMEDIATE HOOPS INTO BENCH ENDS.
4. ATTACH RIDGE PURLIN TO INTERMEDIATE HOOPS USING 5/16"x1-1/4" CARRIAGE BOLT, LOCK WASHER, AND WING NUT.
5. ATTACH CENTER HOOP TO FENCE USING STOP TAB, LOCK WASHER, AND WING NUT.
6. ATTACH CENTER HOOPS TO RIDGE PURLIN USING 5/16"x2" CARRIAGE BOLT, LOCK WASHER, AND WING NUT.

ASSEMBLY INSTRUCTIONS

7. PLACE ENDS OF BASKET PURLIN HOOKS INTO HOLES IN INTERMEDIATE HOOPS. PLACE BASKET PURLINS ONTO HOOKS.
8. PLACE CANOPY OVER FRAME AND SECURE EACH CORNER WITH TIE DOWN ROPES. TIE ROPES TO THE TOP BENCH SUPPORT OF EACH BENCH END. FASTEN THE VELCRO STRAPS AROUND THE CENTER HOOPS.

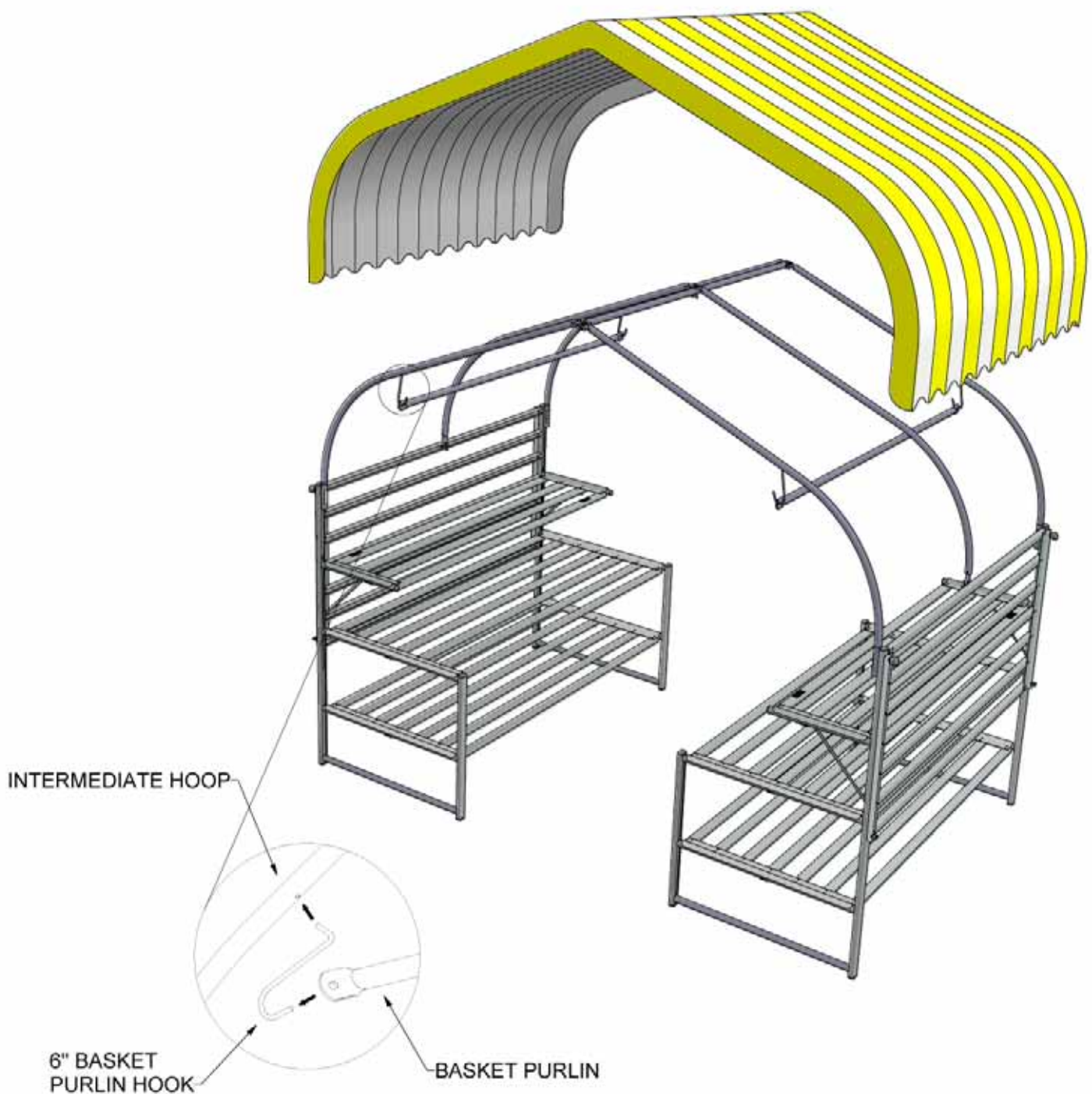

ASSEMBLY INSTRUCTIONS - CONNECTED RUNS

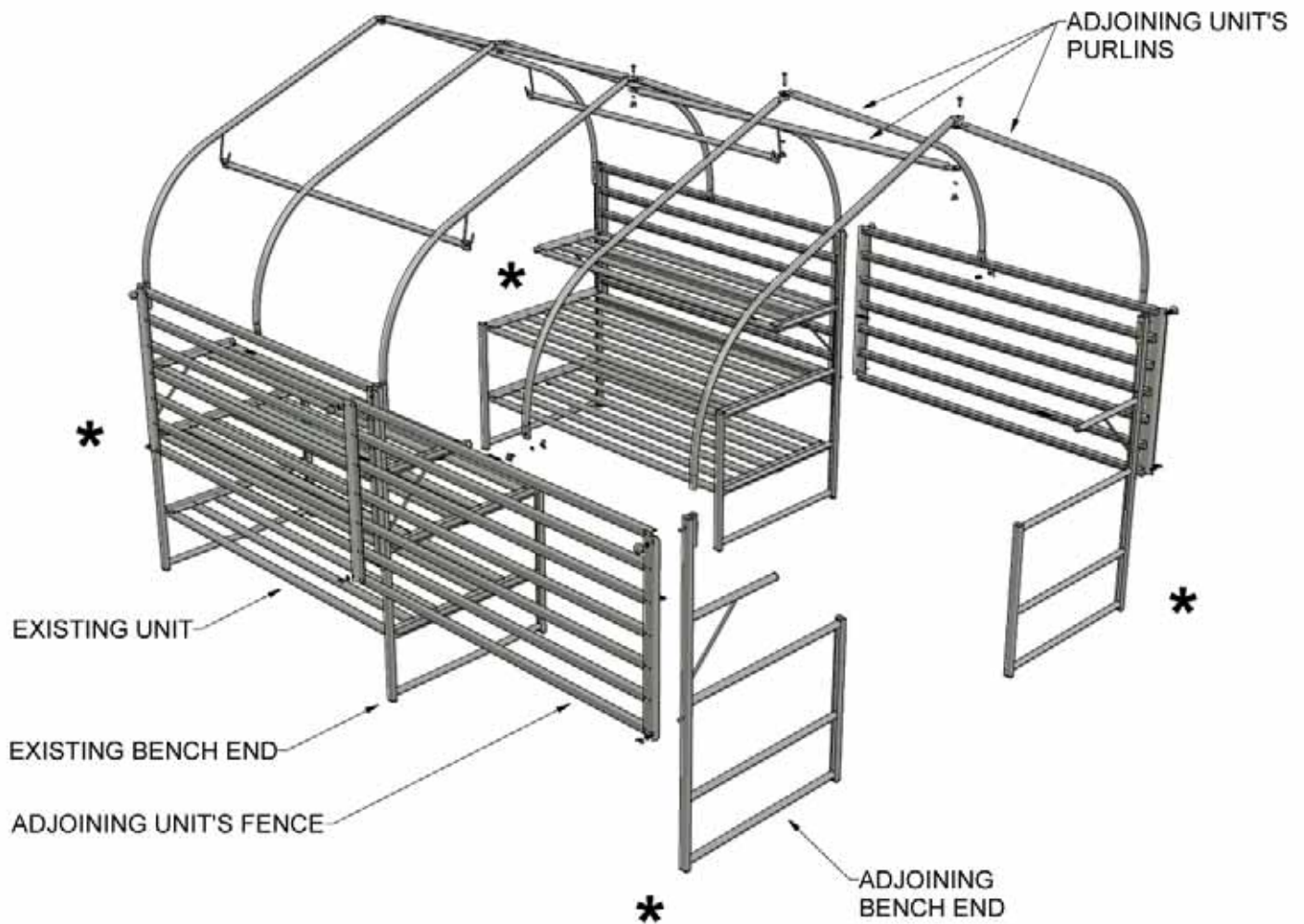

INSTRUCTIONS:

1. ATTACH ADJOINING UNIT'S FENCES AND END STAND TO THE EXISTING UNIT'S END STAND, OVERLAPPING THE FENCES.
2. INSTALL ADJOINING UNIT'S HOOPS AND PURLINS PER STANDARD INSTRUCTIONS ON PAGES 5 & 6.
3. SET BENCH TOPS DOWN OVERLAPPING EXISTING BENCH TOPS AS SHOWN BELOW.
4. SECURE NORSTAD CLIPS ONLY ON END UNITS OF MULTIPLE UNITS JOINED TOGETHER (*).

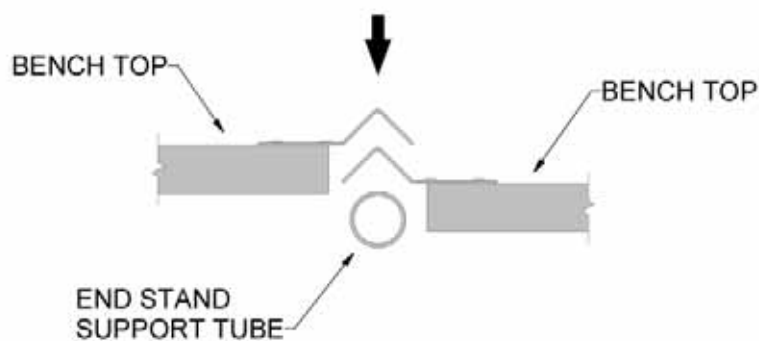

SAFETY GUIDELINES

Do not climb, sit on, or use this product as a ladder. Injuries may occur.

Do not place or install electrical items on this product. Wet conditions are typical and electrical shock may occur.

Do not place this product on a slope that exceeds 3 degrees.

Do not move this display after product is in place. Damage to display and injuries may occur.

Lock casters (when provided) once display is in place to prevent movement.

Remove all debris or obstacles from caster's path before moving.

CARE & MAINTENANCE

To remove loose soil and debris, simply spray the soiled areas with a garden hose. You may need to remove the flop sheets to spray water on the bench tops for cleaning.

Prior to storage, all surfaces of this product should be sprayed down with water and allowed to dry completely.

Limited Warranty

Poly-Tex, Inc. warrants its products to be free from defects in material and workmanship for a period of (1) year from date of invoice. This warranty is provided to the original purchaser of the product and is not transferable. Poly-Tex does not warrant parts not manufactured by Poly-Tex, but does assign any transferable manufacturer or supplier warranties. Should any defect be found, full repair or replacement will be rendered to the customer at no cost following inspection by a Poly-Tex representative and the return of the defective product to our Castle Rock, MN factory. Expenses for removal or reinstallation of defective products will not be covered by the warranty.

POLY-TEX SHALL NOT BE HELD RESPONSIBLE FOR ANY SPECIAL OR CONSEQUENTIAL DAMAGES, OR FOR ANY DELAY IN PERFORMANCE OF THIS WARRANTY BEYOND OUR CONTROL. THIS WARRANTY IS EXCLUSIVE AND IN LIEU OF ALL OTHER WARRANTIES WHETHER IMPLIED, WRITTEN OR ORAL INCLUDING THE WARRANTIES OF MERCHANTABILITY AND FITNESS FOR A PARTICULAR PURPOSE.

This warranty does not cover damage from customer abuse, misuse, improper installation, customer modifications, customer negligence in performing normal maintenance, damage resulting from acts of nature.

Contact information
Poly-Tex, Inc. PO Box 458
27725 Danville Ave Castle Rock, MN 55010
Toll free (800) 852-3443 Fax (651) 463-2479
www.poly-tex.com