

# FTT300 folding table display

## ASSEMBLY INSTRUCTIONS



### IMPORTANT

Please read these instructions carefully before you start to assemble this display. Save these instructions for future reference.



# PARTS IDENTIFICATION

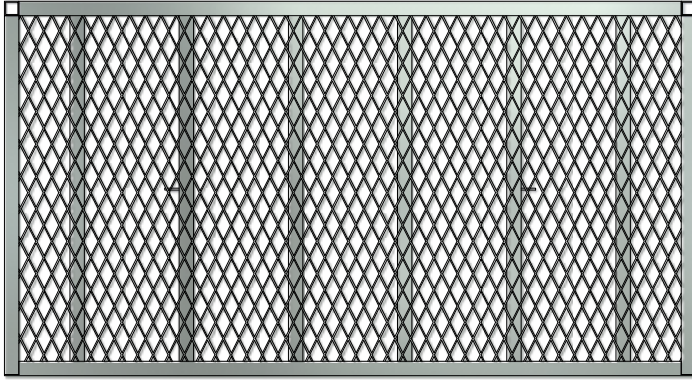

TABLE TOP  
(FTT100)  
qty (1)

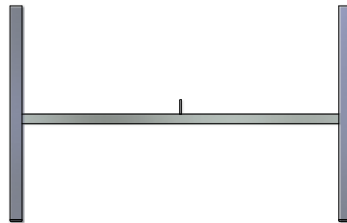

TABLE LEG  
(FTT111)  
qty (2)



LOCKING BRACE  
(FTT112)  
qty (2)



PURLIN SUPPORT  
(FTT103)  
qty (2)



BASKET PURLIN  
(FTT104)  
qty (1)

# OPTIONAL COMPONENTS



SIGN HOLDER  
(FTT105)  
qty (1)

# ASSEMBLY INSTRUCTIONS

- 1 UNFOLD LEGS.
- 2 SLIDE LOCKING BRACE RING OVER BRACE ARMS AS SHOWN.
- 3 INSERT PURLIN SUPPORTS INTO THE SQUARE TUBES ON THE BACK OF THE TABLE TOP.
- 4 INSERT BASKET PURLIN INTO THE PURLIN SUPPORTS.

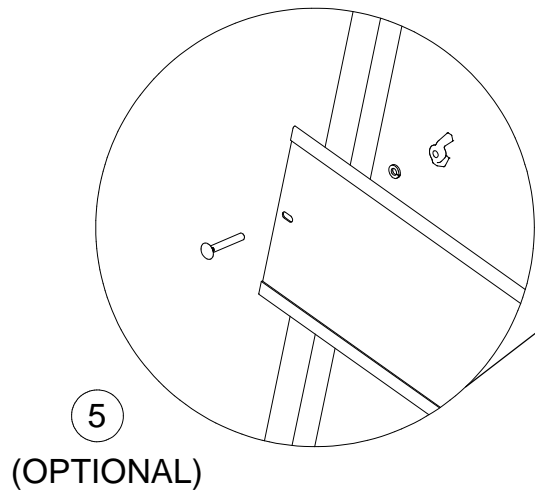

## OPTIONAL:

- 5 FASTEN SIGN HOLDER TO PURLIN SUPPORTS USING CARRIAGE BOLT, LOCK WASHER & WING NUT.

## SAFETY GUIDELINES

Do not climb, sit on, or use this product as a ladder due to possible injuries.

Do not place or install electrical items on this product. Wet conditions are typical and electrical shock is possible.

Do not place this product on a slope that exceeds 10 degrees.

Do not move this display after product is in place. Damage to display and injuries may occur.

## CARE & MAINTENANCE

To remove loose soil and debris, simply spray the soiled areas with a garden hose.

Prior to storage, all surfaces of this product should be sprayed down with water and allowed to dry completely.

Store folding table in a flat position.

## TOOLS & EQUIPMENT REQUIRED

No tools are required to assemble this product.

### Limited Warranty

Poly-Tex, Inc. warrants its products to be free from defects in material and workmanship for a period of (1) year from date of invoice. This warranty is provided to the original purchaser of the product and is not transferable. Poly-Tex does not warrant parts not manufactured by Poly-Tex, but does assign any transferable manufacturer or supplier warranties. Should any defect be found, full repair or replacement will be rendered to the customer at no cost following inspection by a Poly-Tex representative and the return of the defective product to our Castle Rock, MN factory. Expenses for removal or reinstallation of defective products will not be covered by the warranty.

**POLY-TEX SHALL NOT BE HELD RESPONSIBLE FOR ANY SPECIAL OR CONSEQUENTIAL DAMAGES, OR FOR ANY DELAY IN PERFORMANCE OF THIS WARRANTY BEYOND OUR CONTROL. THIS WARRANTY IS EXCLUSIVE AND IN LIEU OF ALL OTHER WARRANTIES WHETHER IMPLIED, WRITTEN OR ORAL INCLUDING THE WARRANTIES OF MERCHANTABILITY AND FITNESS FOR A PARTICULAR PURPOSE.**

This warranty does not cover damage from customer abuse, misuse, improper installation, customer modifications, customer negligence in performing normal maintenance, damage resulting from acts of nature.

Contact information  
Poly-Tex, Inc. PO Box 458  
27725 Danville Ave Castle Rock, MN 55010  
Toll free (800) 852-3443 Fax (651) 463-2479  
[www.poly-tex.com](http://www.poly-tex.com)