

# **FB3025** flat mate display

## ASSEMBLY INSTRUCTIONS



### IMPORTANT

Please read these instructions carefully before you start to assemble this display. Save these instructions for future reference.



# PARTS IDENTIFICATION

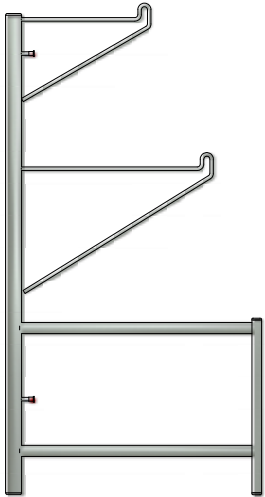

FB2023  
BENCH END  
(2)

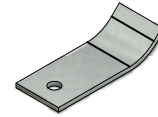

FT3600  
NORSTAD CLIP  
(4)

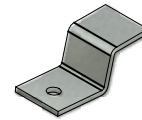

FT3200  
STACKER CLIP  
(4)

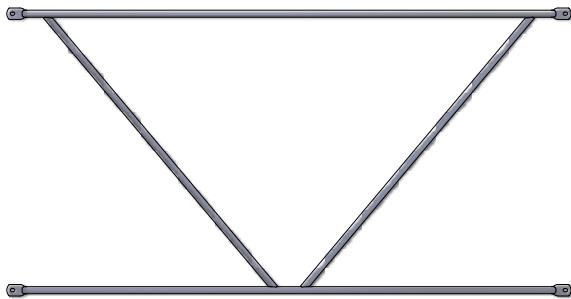

FB2533  
STABILIZER  
(1)



NB1924  
THUMB SCREW  
(8)



RF2555  
23" x 6' BENCH TOP  
(2)



NB1901  
WING NUT  
(4)



RF2554  
18" x 6' BENCH TOP  
(1)



NB1923  
NYLON WASHER  
(4)



RF2545  
12" x 6' BENCH TOP  
(1)

## TOOLS & EQUIPMENT REQUIRED

No tools are required for the assembly of this product.

# ASSEMBLY INSTRUCTIONS

## FB3025

### FLAT MATE DISPLAY

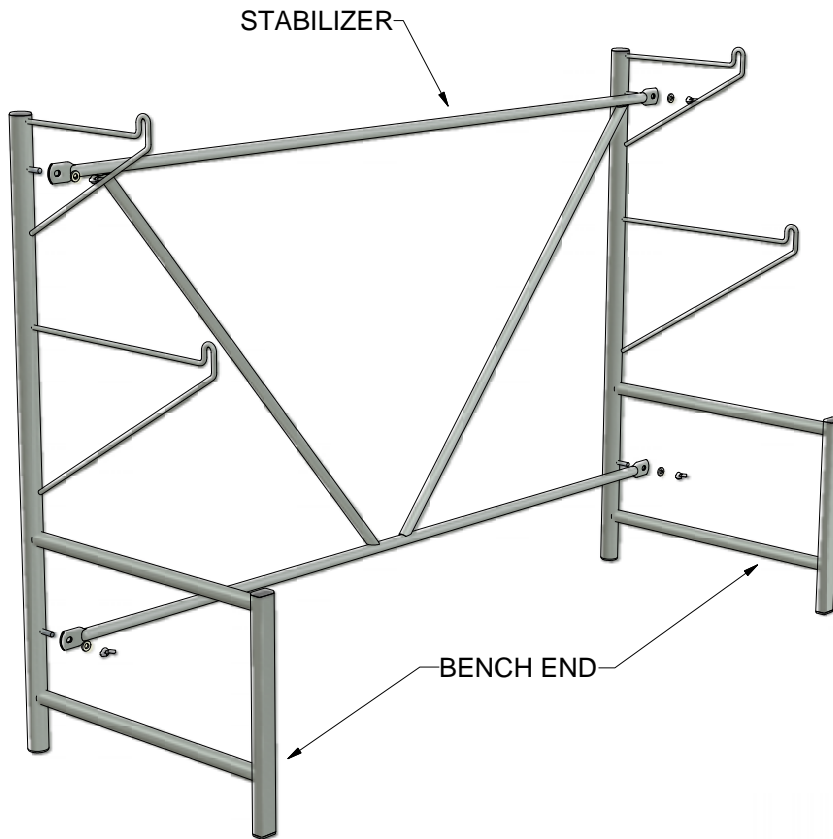

1. ATTACH STABILIZER TO THREADED STUDS ON BENCH ENDS USING NYLON WASHERS AND WING NUTS.
2. SET BENCH TOPS IN PLACE.
3. SECURE UPPER BENCH TOPS WITH STACKER CLIPS. SEE **FIGURE 1**
4. SECURE LOWER BENCH TOPS WITH NORSTAD CLIPS. SEE **FIGURE 2**

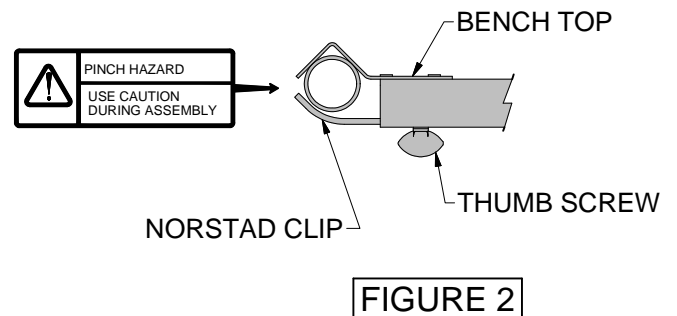
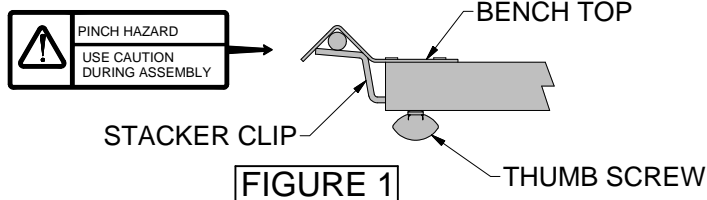
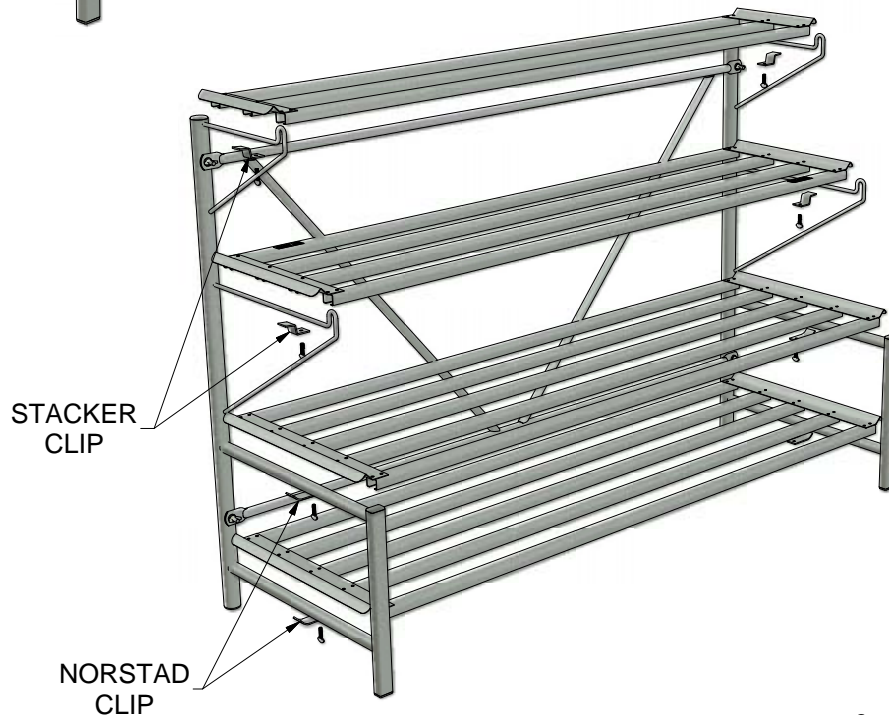

# ASSEMBLY INSTRUCTIONS - CONNECTED RUNS

## FB3025

### FLAT MATE DISPLAY

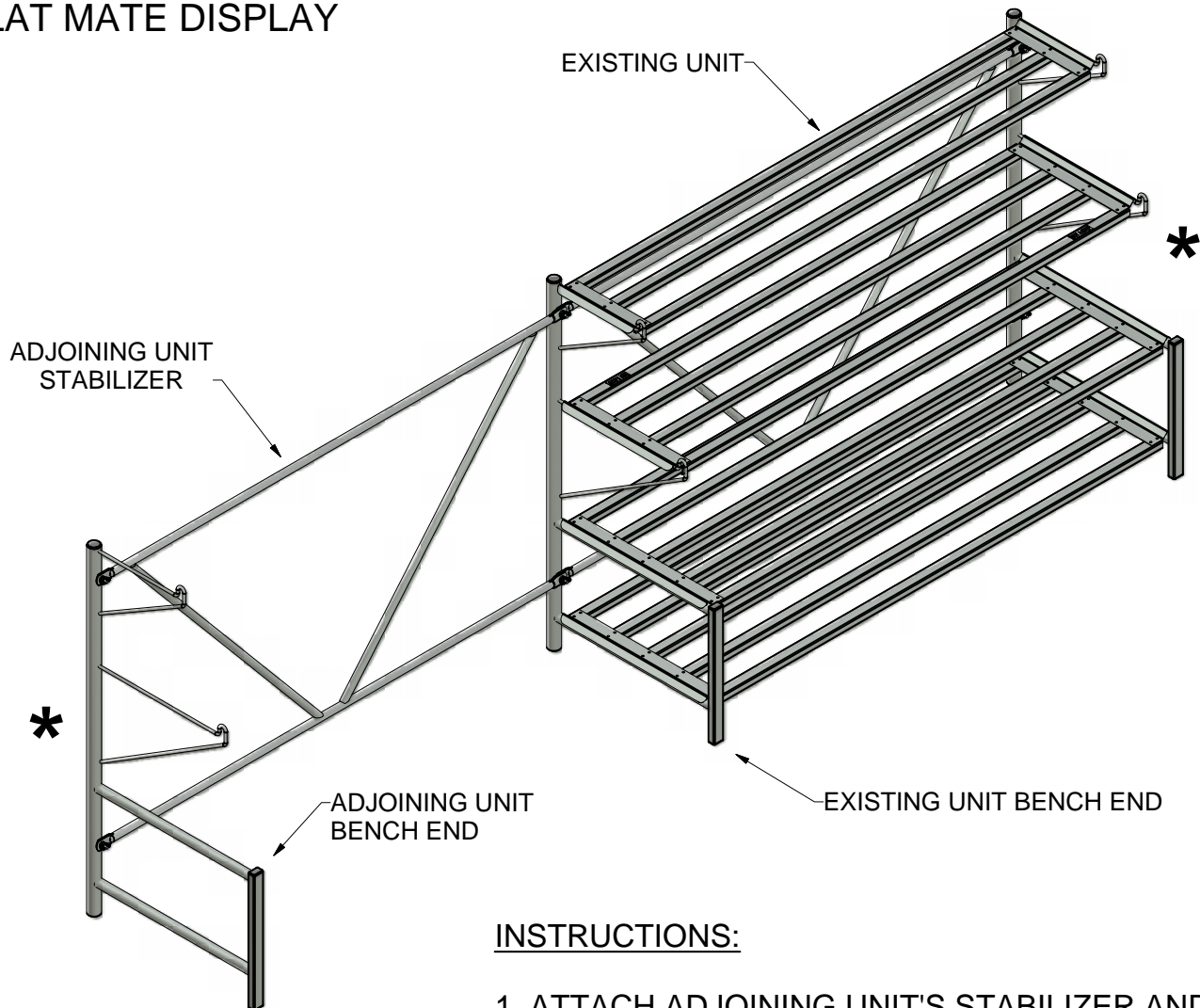

#### INSTRUCTIONS:

1. ATTACH ADJOINING UNIT'S STABILIZER AND BENCH END TO THE EXISTING UNIT'S BENCH END. SET BENCH TOPS OVERLAPPING EXISTING BENCH TOPS AS SHOWN IN FIGURE 1.

\* SECURE CLIPS ONLY ON END UNITS OF MULTIPLE UNITS JOINED TOGETHER.

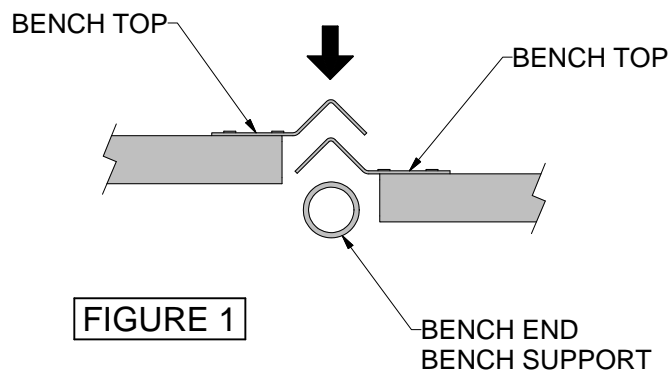

FIGURE 1

# CASTER OPTION



## INSTRUCTIONS:

1. SLIDE CASTER RAIL INTO BOTTOM OF BENCH ENDS.
2. TIGHTEN THUMB SCREWS TO LOCK INTO PLACE.

BENCH END WITH CASTER (FB2026)



CASTER RAIL (FB2004)

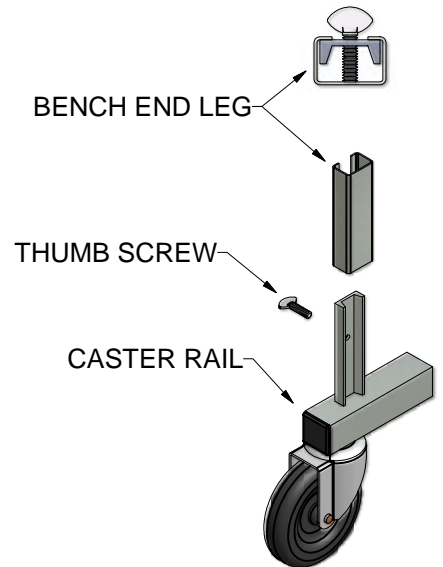

BENCH END LEG

THUMB SCREW

CASTER RAIL

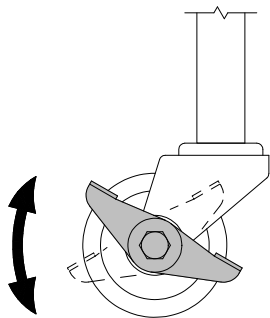

ONCE DISPLAY IS IN PLACE, ALL CASTERS MUST BE LOCKED TO PREVENT MOVEMENT. THE BRAKE IS ACTIVATED BY ROTATING THE LEVER FROM THE "OFF" POSITION TO THE "ON" POSITION.

## PARTS IDENTIFICATION

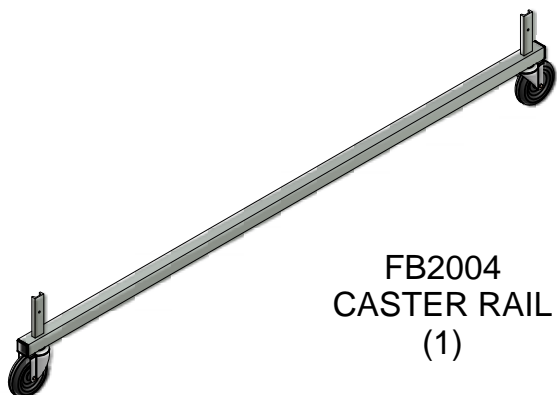

FB2004  
CASTER RAIL  
(1)

FB2026  
BENCH END  
WITH CASTER  
(2)

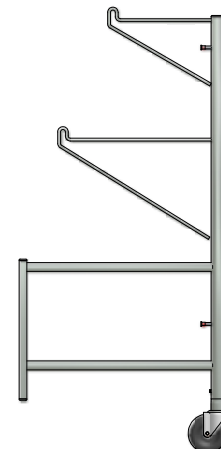

## SAFETY GUIDELINES

**Do not** climb, sit on, or use this product as a ladder. Injuries may occur.

**Do not** place or install electrical items on this product. Wet conditions are typical and electrical shock may occur.

**Do not** place this product on a slope that exceeds 3 degrees.

**Do not** move this display after product is in place. Damage to display and injuries may occur.

**Lock casters** (when provided) once display is in place to prevent movement.

**Remove all** debris or obstacles from caster's path before moving.

## CARE & MAINTENANCE

To remove loose soil and debris, simply spray the soiled areas with a garden hose.

Prior to storage, all surfaces of this product should be sprayed down with water and allowed to dry completely.

### Limited Warranty

Poly-Tex, Inc. warrants its products to be free from defects in material and workmanship for a period of (1) year from date of invoice. This warranty is provided to the original purchaser of the product and is not transferable. Poly-Tex does not warrant parts not manufactured by Poly-Tex, but does assign any transferable manufacturer or supplier warranties. Should any defect be found, full repair or replacement will be rendered to the customer at no cost following inspection by a Poly-Tex representative and the return of the defective product to our Castle Rock, MN factory. Expenses for removal or reinstallation of defective products will not be covered by the warranty.

**POLY-TEX SHALL NOT BE HELD RESPONSIBLE FOR ANY SPECIAL OR CONSEQUENTIAL DAMAGES, OR FOR ANY DELAY IN PERFORMANCE OF THIS WARRANTY BEYOND OUR CONTROL. THIS WARRANTY IS EXCLUSIVE AND IN LIEU OF ALL OTHER WARRANTIES WHETHER IMPLIED, WRITTEN OR ORAL INCLUDING THE WARRANTIES OF MERCHANTABILITY AND FITNESS FOR A PARTICULAR PURPOSE.**

This warranty does not cover damage from customer abuse, misuse, improper installation, customer modifications, customer negligence in performing normal maintenance, damage resulting from acts of nature.

Contact information  
Poly-Tex, Inc. PO Box 458  
27725 Danville Ave Castle Rock, MN 55010  
Toll free (800) 852-3443 Fax (651) 463-2479  
[www.poly-tex.com](http://www.poly-tex.com)