

EC2000

ASSEMBLY INSTRUCTIONS

2 level end cap

IMPORTANT

Please read these instructions carefully before beginning to assemble this display. Save instructions for future reference.

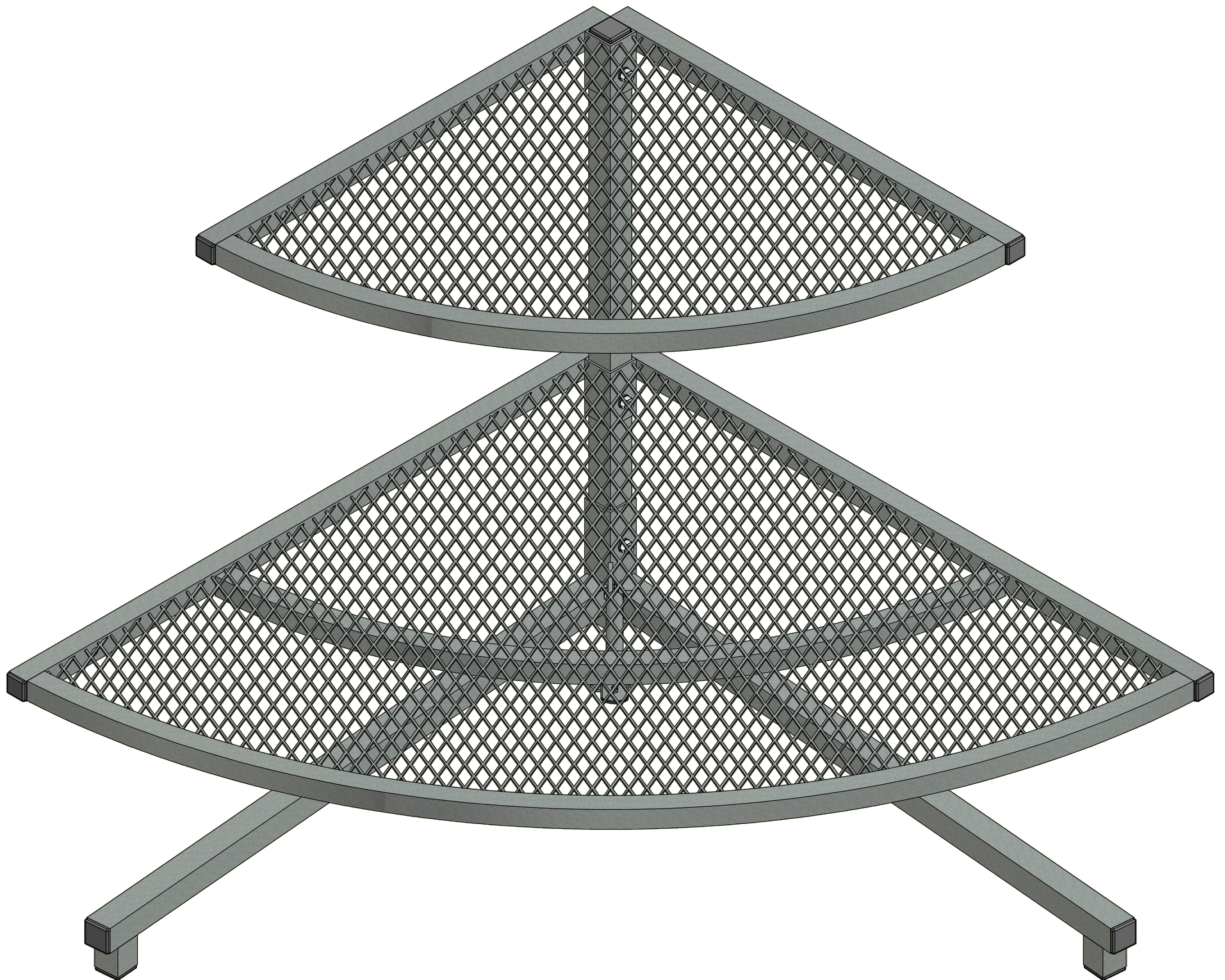

P.O. Box 458
27725 Danville Avenue
Castle Rock, MN 55010
www.poly-tex.com

U.S. & Canada Toll Free
800-852-3443
(651) 463-7009
fax (651) 463-2479



POLY-TEX
Greenhouse & Display Systems

REV: AA-120319

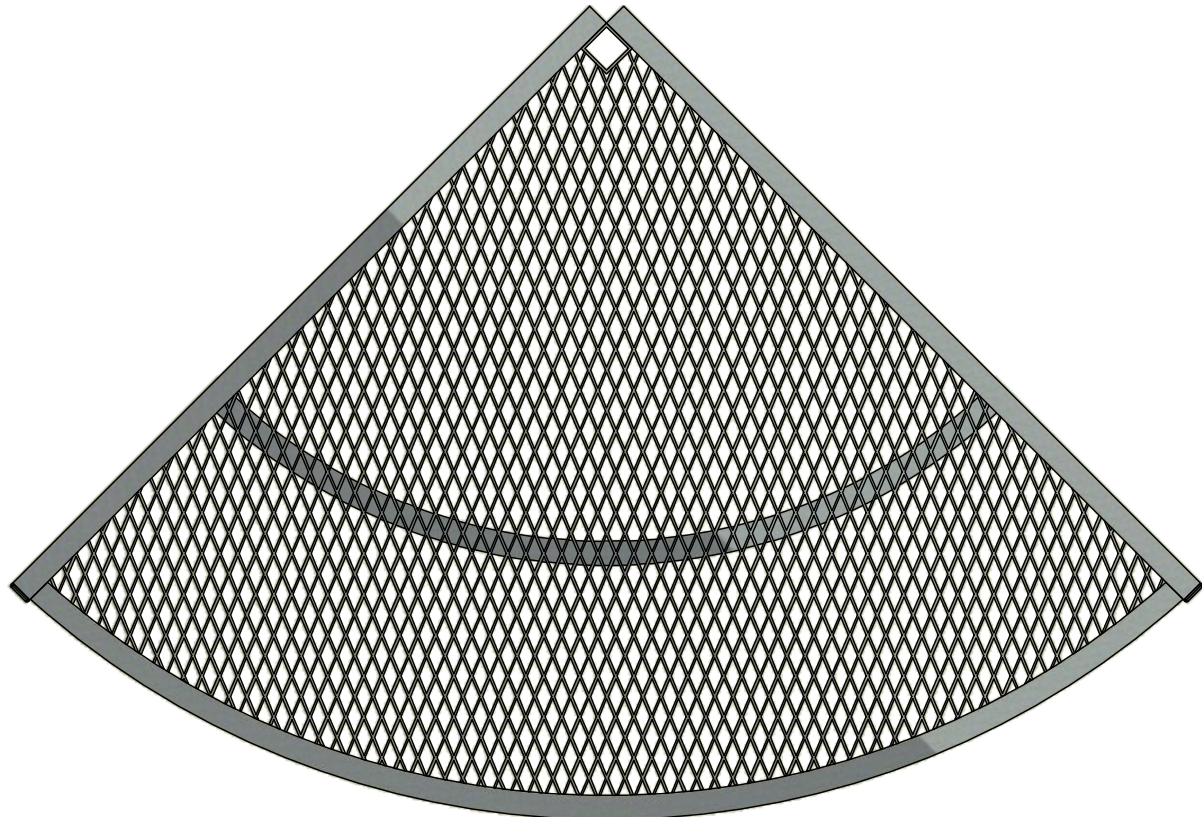
PARTS IDENTIFICATION

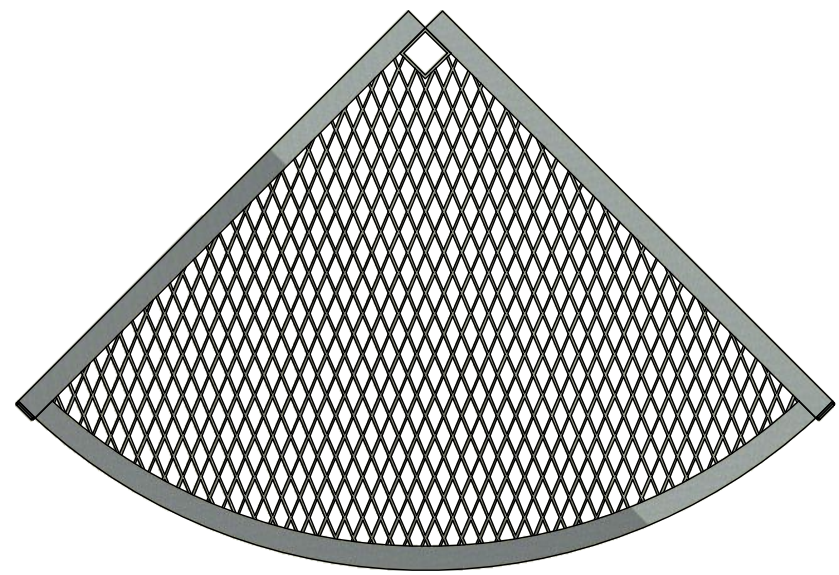

EC2011
END CAP
BOTTOM BENCH
(1)



EC2004
END CAP
MIDDLE BENCH
(1)

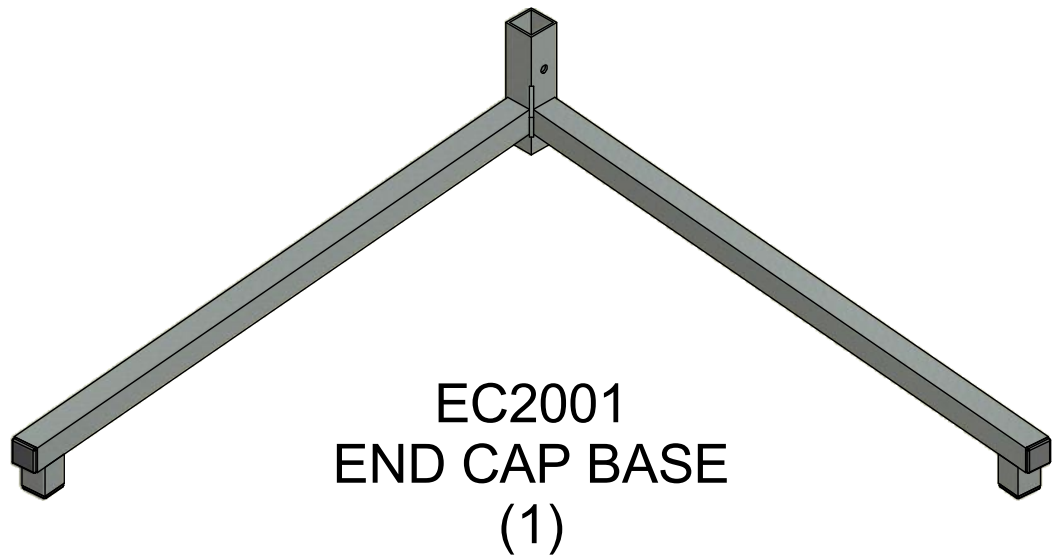

EC2001
END CAP BASE
(1)



EC2007
END CAP VERTICAL
(1)



EC2012
BOTTOM BENCH
SUPPORT
(1)

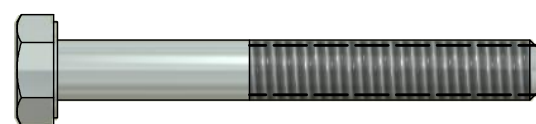

NB1850
5/16" x 2-1/2" HEX BOLT
(2)

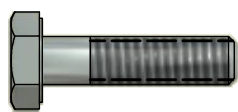

NB1763
1/4" x 1" HEX BOLT
(1)

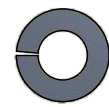

1/4" LOCK WASHER
(NB1860)
QTY (2)



1/4" HEX NUT
(NB1870)
QTY (2)

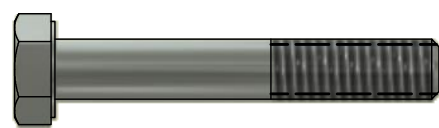

NB1848
5/16" x 2" HEX BOLT
(3)

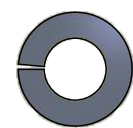

NB1862
5/16" LOCK WASHER
(5)



NB1872
5/16" HEX NUT
(5)

TOOLS & EQUIPMENT REQUIRED

7/16", 1/2", and 9/16" open end wrenches and an adjustable wrench are required to assemble this display.

ASSEMBLY INSTRUCTIONS

1. SLIDE END CAP VERTICAL INTO THE END CAP BASE. FASTEN WITH 5/16" HEX BOLT, LOCK WASHER, AND HEX NUT.
2. SLIDE END CAP BOTTOM BENCH OVER END CAP VERTICAL. ALIGN WITH MOUNTING HOLE. FASTEN WITH 5/16" HEX BOLT, LOCK WASHER, AND HEX NUT.
3. SLIDE END CAP MIDDLE BENCH OVER END CAP VERTICAL. ALIGN WITH MOUNTING HOLE. FASTEN WITH 5/16" HEX BOLT, LOCK WASHER, AND HEX NUT.

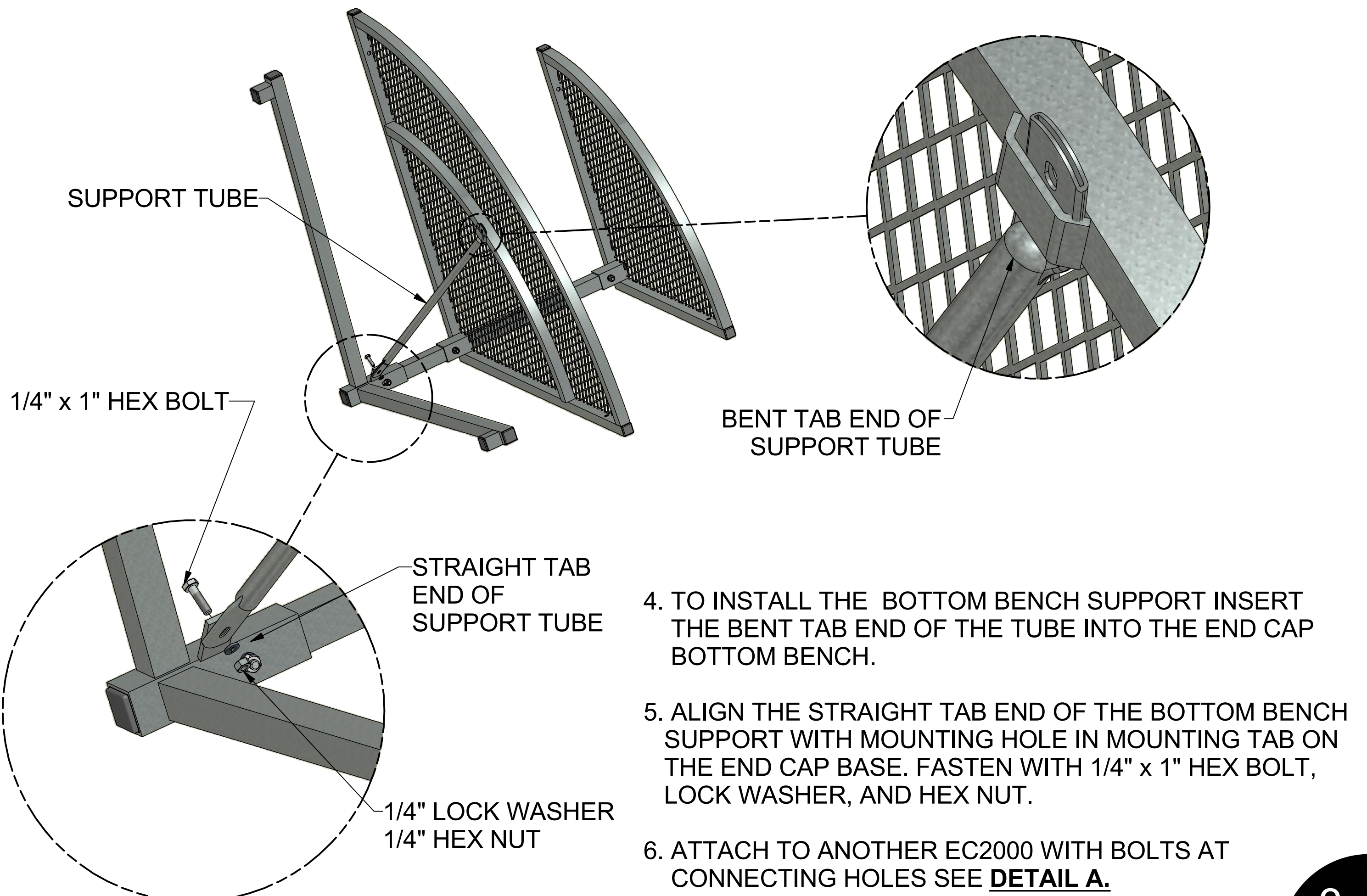
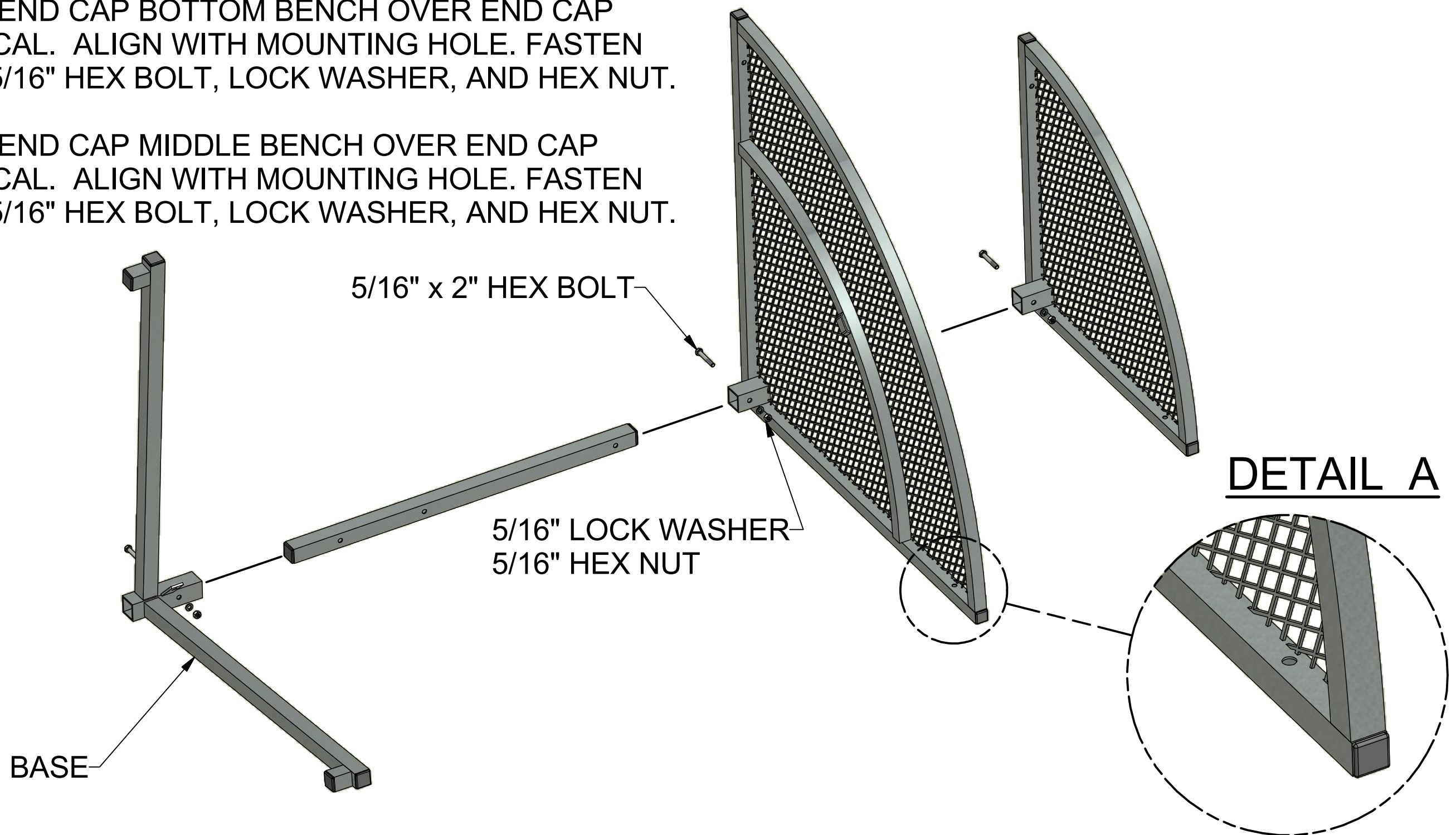

SAFETY GUIDELINES

Do not climb, sit on, or use this product as a ladder. Injuries may occur.

Do not place or install electrical items on this product. Wet conditions are typical and electrical shock may occur.

Do not place this product on a slope that exceeds 3 degrees.

Do not move this display after product is in place. Damage to display and injuries may occur.

CARE & MAINTENANCE

To remove loose soil and debris, simply spray the soiled areas with water from a garden hose.

Prior to storage, all surfaces of this product should be sprayed down with water and allowed to dry completely.

Limited Warranty

Poly-Tex, Inc. warrants its products to be free from defects in material and workmanship for a period of (1) year from date of invoice. This warranty is provided to the original purchaser of the product and is not transferable. Poly-Tex does not warrant parts not manufactured by Poly-Tex, but does assign any transferable manufacturer or supplier warranties. Should any defect be found, full repair or replacement will be rendered to the customer at no cost following inspection by a Poly-Tex representative and the return of the defective product to our Castle Rock, MN factory. Expenses for removal or reinstallation of defective products will not be covered by the warranty.

POLY-TEX SHALL NOT BE HELD RESPONSIBLE FOR ANY SPECIAL OR CONSEQUENTIAL DAMAGES, OR FOR ANY DELAY IN PERFORMANCE OF THIS WARRANTY BEYOND OUR CONTROL. THIS WARRANTY IS EXCLUSIVE AND IN LIEU OF ALL OTHER WARRANTIES WHETHER IMPLIED, WRITTEN OR ORAL INCLUDING THE WARRANTIES OF MERCHANTABILITY AND FITNESS FOR A PARTICULAR PURPOSE.

This warranty does not cover damage from customer abuse, misuse, improper installation, customer modifications, customer negligence in performing normal maintenance, damage resulting from acts of nature.

Contact information
Poly-Tex, Inc. PO Box 458
27725 Danville Ave Castle Rock, MN 55010
Toll free (800) 852-3443 Fax (651) 463-2479
www.poly-tex.com